



**TECHNISCHE
UNIVERSITÄT
DRESDEN**

Faculty of Civil Engineering Institute of Construction Informatics

Analyzing the Potential of Building Integrated Photovoltaic Systems in a typical German and Korean Multi-Family House

by

Seoyeon Son

from

Gwangju, South Korea

A Thesis submitted to the Faculty of Civil Engineering, Institute of Construction Informatics of the University of Technology Dresden in partial fulfillment of the requirements for the degree of

Master of Science

Responsible Professors

Prof. Dr.-Ing. habil. Karsten Menzel

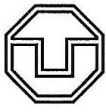
Advisor

Dr. rer. nat. Christoph Schünemann

M.Sc. Janakiram Karlapudi

Dresden, July and 2020

(insert here the original sheet with your task)



**TECHNISCHE
UNIVERSITÄT
DRESDEN**

Fakultät Bauingenieurwesen Institut für Bauinformatik

Master Thesis Task Sheet
Masterarbeit Aufgabenstellung

Name: Ms. Seoyeon Son (student ID / Matrikel Nr.: 4738006)

Study Course: Advanced Computational and Civil Engineering Structural Studies (ACCESS)

Topic: Analyzing the Potential of Building Integrated Photovoltaic Systems in a typical German and Korean Multi-Family House
(Eine vergleichende Analyse integrierter Photovoltaik-Systeme am Beispiel von Mehrfamilienhäusern in Deutschland und Korea)

Context:

The concept of energy simulation is vital to energy efficiency analysis in buildings. Moreover, the application of renewable and sustainable energy in buildings is one of the key sectors for saving energy and the development towards a symbiotic society, i.e. a society in which the environment and the human species can coexist together.

In particular, highly efficient photovoltaic (PV) energy resources and geothermal systems which are continuously available can be combined in a symbiotic way to play an important role for sustainable building operation based on renewable energy sources.

Objective:

The objective of this thesis is to analyze the energy performance of two multi-family houses, representative for Korea and for Germany based on an energy simulation model. The aim is to demonstrate the impact of transparent photovoltaic systems installed within the window area as well as the complete façade.

Scope of work:

The below specified steps shall be discussed in the Thesis:

- 1.) A review and feasibility study of semi-transparent photovoltaic systems. Two distinct implementation techniques shall be discussed: (a) installation in windows and (b) installation on non-transparent parts of a building's façade.
- 2.) Analysis of the energy performance of two representative residential buildings (Germany, Korea) in the current state (i.e. without PV-systems) using building simulation.
- 3.) A comparative analysis of the energy performance of the residential buildings after an assumed renovation case, i.e. with integrated PV-systems installed.
- 4.) Investigation of possible usage of the energy generated from PV-systems during the building's operation.
- 4.a) To explore the feasibility of alternative seasonal energy storage using the above specified PV-systems in combination with geothermal storage systems.



DRESDEN
concept
E.ON Energy Research Center
University of Technology
Dresden

Die besonderen Hinweise für die Anfertigung Masterarbeit des Instituts sind zu beachten.

(insert here the original sheet with your task)

Supervision, Examination, and Key Dates:

Supervisor 1:	M.Sc. Janakiram Karlapudi
Supervisor 2:	Dr. rer. nat. Christoph Schünemann
Responsible academic staff and Examiner 1:	Prof. Dr.-Ing. habil. Karsten Menzel
Examiner 2:	Dr. rer. nat. Christoph Schünemann

Topic handed over to student: 20.03.2020

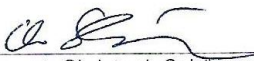
Expected submission date: 20.07.2020



Ms. Seoyeon Son



Prof. Dr.-Ing. habil. Karsten Menzel



Dr. rer. nat. Christoph Schünemann

Declaration of originality

I confirm that this assignment is my own work and that I have not sought or used the inadmissible help of third parties to produce this work. I have fully referenced and used inverted commas for all text directly quoted from a source. Any indirect quotations have been duly marked as such.

This work has not yet been submitted to another examination institution – neither in Germany nor outside Germany – neither in the same nor in a similar way and has not yet been published.

Dresden,

Place, Date

(Signature)

Acknowledgements

First of all, I would like to show appreciation to my professor, Karsten Menzel, for giving me the opportunity to pursue this work. During my work, he has given generous support, insightful direction, and hopeful advice. When I first suggested my topic in the situation where I might be able to do, he supported my new attempt positively. Also, he said the successful results are not only researches and the attempts that have not been made before are worth ones even if the results were not successful. I truly admire his tremendous knowledge as well as the brilliant personality that leads students as an educator.

Besides I would like to thank my supervisor, Christoph Schünemann and Janakiram Karlapudi for their constant supports and constructive feedback. Thanks to Yukung Park, who provided detailed materials related to Korean construction.

Finally, I am thankful for my father who is always taking care of me in the heaven, my mother, and sister who have been giving me endless love and medicine since I was sick and got stressful, and the rest members in my family. Furthermore, I am also thankful for my two precious cats that came with me to Germany.

Abstract

One of the important aims of Germany and Korea is to reduce carbon dioxide emissions. Both countries made policies to improve energy performance in the building sector for obtaining this goal. There are two kinds of strategies which make energy demand in buildings reduced as well as produce energy for buildings. By enhancing insulations and implementing renewables e.g. photovoltaic systems producing electricity with low carbon emissions. Both models can achieve better energy efficiency.

This thesis is divided into three parts: state of art analysis, methodology, and results of analysis.

The state of art analysis provides an introduction and considerations of photovoltaics and comparisons between Germany and Korean related to construction and energy in buildings.

The methodology indicates the case study models in terms of construction data. Each scenario proposes how to simulate under different conditions. The first scenario proposes energy simulations for the German and Korean models in the initial state. The next scenario proposes energy simulations in the renovated state. Other scenarios are to simulate by applying semi-transparent and opaque PV systems.

The results of analysis display results in each scenario and comparisons between two models related to energy demands for heating and cooling, electricity production generated from PV modules according to the scenarios.

The conclusion part of this thesis summarizes the results obtained from the energy simulations. Variations applied solar modules in the renovated states reduced electricity demands for heating and cooling and CO₂ emissions from 43.2% to 69.6% compared with models in the early state. Finally, this approach is proposed to improve a solution to improve energy performance as much as 67% and 32.7 % of the targets that Germany and Korea set in the building sector, respectively.

Table of Contents

1	Introduction.....	1
1.1	Motivation	1
2	State of Art Analysis.....	3
2.1	Photovoltaics.....	3
2.1.1	Introduction	3
2.1.2	Classifications	4
2.1.3	Considerations of PV installation	7
2.2	Comparisons between Germany and South Korea.....	9
2.2.1	Residential building age	9
2.2.2	Electricity generation by fuel	10
2.2.3	Certification systems for buildings	11
2.2.4	Energy simulation software – IDA ICE	14
3	Methodology.....	15
3.1	Research Framework.....	15
3.2	Case Study Models	16
3.2.1	German Residential Building.....	16
3.2.2	Korean Residential Building.....	17
3.3	Energy Simulation Scenarios.....	18
3.3.1	Scenario 1 – Existing Residential Buildings	18
3.3.2	Scenario 2 – Retrofitting with Additional Insulations and Systems.....	24
3.3.3	Scenario 3 – Semi-transparent Photovoltaics Installation on Windows.....	28
3.3.4	Scenario 4 – Opaque Photovoltaics Installation on Walls	32
4	Results of Analysis.....	34
4.1	Results of Simulations	34
4.1.1	Results of Scenario 1.....	34
4.1.2	Results of Scenario 2.....	38
4.1.3	Results of Scenario 3.....	41
4.1.4	Results of Scenario 4.....	50
4.2	Analysis	54
4.2.1	Electricity demand of Scenario 1 and 2.....	54
4.2.2	Variations based on Scenario 1 with no Electricity production	55

4.2.3 Variations based on Scenario 2 with no Electricity production	57
4.2.4 Variations based on Scenario 1 with Electricity production.....	58
4.2.5 Variations based on Scenario 2 with Electricity production.....	59
4.2.6 Scenario 1 and Variations based on Scenario 2 with Electricity production ..	61
4.2.7 Electricity Production fed into Grid and Electricity demand for Internal loads	62
5 Conclusion and Future Work.....	64
5.1 Conclusion.....	64
5.2 Future Work.....	66
6 References.....	67
7 Appendix/Appendices	70
7.1 Variations based on Scenario 1	70
7.1.1 South windows with semi-transparent PV modules based on Scenario 1 in the German model	70
7.1.2 South and West walls with opaque PV modules based on Scenario 1 in the German model	70
7.1.3 East and West slope roofs with opaque PV modules based on Scenario 1 in the German model	71
7.1.4 Scenario 1 with all variations in the German model.....	71
7.1.5 East and West windows with semi-transparent PV modules based on Scenario 1 in the Korean model	72
7.1.6 South walls with opaque PV modules based on Scenario 1 in the Korean model	72
7.1.7 East and West roofs with opaque PV modules based on Scenario 1 in the Korean model.....	73
7.1.8 Scenario 1 with all variations in the Korean model.....	73
7.2 Variations based on Scenario 2	74
7.2.1 South windows with semi-transparent PV modules based on Scenario 2 in the German model	74
7.2.2 South and West walls with opaque PV modules based on Scenario 2 in the German model	74
7.2.3 East and West slope roofs with opaque PV modules based on Scenario 2 in the German model	75
7.2.4 Scenario 2 with all variatons in the German model.....	75
7.2.5 East and West windows with semi-transparent PV modules based on Scenario 2 in the Korean model	76

7.2.6 South walls with opaque PV modules based on Scenario 2 in the Korean model	76
7.2.7 East and West roofs with opaque PV modules based on Scenario 2 in the Korean model.....	77
7.2.8 Scenario 2 with all variatons in the Korean model	77

List of Figures

Figure 2.1 Solar cell and module [7]	3
Figure 2.2 PV solar systems [8].....	4
Figure 2.3 Solar cell types according to light absorption layer materials [8].....	5
Figure 2.4 Classification of solar cells [9]	6
Figure 2.5 Annual power quantity by solar radiation and azimuth [14].....	8
Figure 2.6 Residential building age in Dresden and Seoul [16] [17].....	10
Figure 2.7 2018 Electricity generation by fuel [19]	11
Figure 3.1 Diagram of Process.....	15
Figure 3.2 German Multi-family House and Floor Plan [27].....	17
Figure 3.3 Korean Multi-family House and Floor Plan [28] [29]	17
Figure 3.4 Dry-bulb Temperature and Humidity of Germany and Korea	20
Figure 3.5 Solar Radiance of Germany and Korea.....	21
Figure 3.6 Sky Clearness of Germany and Korea.....	21
Figure 3.7 Floor plans of German and Korean models retrofitted [27] [30].....	25
Figure 3.8 PV Structure for German roof [34]	33
Figure 4.1 Result of Electricity demands for German model of Scenario 1	36
Figure 4.2 Result of Electricity demands for Korean model of Scenario 1	37
Figure 4.3 Result of Electricity demands for German model of Scenario 2	39
Figure 4.4 Result of Electricity demands for Korean model of Scenario 2	40
Figure 4.5 Result of Electricity demand for German model of Scenario 3 based on Scenario 1	42
Figure 4.6 Result of Electricity demand for Korean model of Scenario 3 based on Scenario 1	43
Figure 4.7 Result of Electricity demand for German model of Scenario 3 based on Scenario 2	45
Figure 4.8 Result of Electricity demand for Korean model of Scenario 3 based on Scenario 2	46
Figure 4.9 Annual Electricity Production from Semi-transparent PV modules.....	47
Figure 4.10 Annual Electricity Production per m ² from Semi-transparent PV modules	48
Figure 4.11 Floor plans with Average Illuminance of each Scenario for the German and Korean Models on the 21st of December.....	49

Figure 4.12 Comparison of Monthly Average Daylight for the rooms in Scenario 1 and Scenario 3 based on Scenario 2	49
Figure 4.13 Comparison of Monthly Average Daylight for the rooms in Scenario 1 and Scenario 3 based on Scenario 2	50
Figure 4.14 Annual Electricity Production from Opaque PV modules	51
Figure 4.15 Annual Electricity Production per 1 m ² from Walls and Roof with Opaque PV modules.....	51
Figure 4.16 Variations based on Scenario 1 related to Electricity production	52
Figure 4.17 Variations based on Scenario 2 related to Electricity production	53
Figure 4.18 Comparison of Electricity demands for heating and cooling per m ² in Scenario 1 and Scenario 2.....	55
Figure 4.19 Comparison of Electricity demands for heating and cooling per m ² in Variations based on Scenario 1 with no electricity production.....	56
Figure 4.20 Comparison of Electricity demands for heating and cooling per m ² in Variations based on Scenario 2 with no electricity production.....	58
Figure 4.21 Comparison of Electricity demands per m ² in Variations based on Scenario 1 with electricity production	59
Figure 4.22 Comparison of Electricity demands per m ² in Variations based on Scenario 2 with electricity production	60
Figure 4.23 Comparison of Electricity demands per m ² in Scenario 1 and Variations based on Scenario 2	61
Figure 4.24 Electricity from PV modules fed into grid and Internal loads in 16 variations	63

List of Tables

Table 2.1 Efficiency and Characteristics of Solar Cell Types 2018 [8].....	7
Table 2.2 Considerations of PV installation [14].....	8
Table 2.3 Comparison of PV panel efficiency according to angles of inclination [14]	8
Table 2.4 Residential building age in Dresden 2018 [16].....	9
Table 2.5 Residential building age in Seoul 2018 [17].....	10
Table 2.6 Electricity generation by fuel 2018 [19].....	10
Table 2.7 Certification systems for sustainable buildings [20] [21].....	12
Table 2.8 Certification systems for energy performance in buildings [22] [23] [24]	13
Table 2.9 Features of IDA ICE [26]	14
Table 3.1 Location and Weather data input.....	19
Table 3.2 Weather data in Germany	19
Table 3.3 Weather data in Korea.....	20
Table 3.4 Activity Data of Germany and Korea.....	22
Table 3.5 Structural components of the German and Korean Models [27] [29] [30].....	24
Table 3.6 Renovation detail for the German model [27].....	26
Table 3.7 Renovation detail for the Korean model [30]	27
Table 3.8 Chosen Semi-transparent Solar Module [31].....	29
Table 3.9 Parameters for Semi-transparent PV	30
Table 3.10 Parameters of g value and Transmittance with Semi-transparent PV.....	30
Table 3.11 Chosen Opaque Solar Module [33].....	32
Table 3.12 Parameters for Opaque PV	33
Table 4.1 Comparison of Electricity demand and CO ₂ emission in Scenario 1.....	35
Table 4.2 CO ₂ emission factors for Germany and Korea [35] [36].....	35
Table 4.3 Result of Electricity demands for German model of Scenario 1.....	36
Table 4.4 Result of Electricity demands for Korean model of Scenario 1	37
Table 4.5 Comparison of Electricity demands and CO ₂ emission of Scenario 2.....	38
Table 4.6 Result of Electricity demands for German model of Scenario 2.....	39
Table 4.7 Result of Electricity demands for Korean model of Scenario 2	40
Table 4.8 Comparison of Electricity demand and CO ₂ emission of Scenario 3 based on Scenario 2.....	41

Table 4.9 Result of Electricity demand for German model of Scenario 3 based on Scenario 1	42
Table 4.10 Result of Electricity demand for Korean model of Scenario 3 based on Scenario 1	43
Table 4.11 Comparison of Electricity demand and CO ₂ emission of Scenario 3 based on Scenario 2.....	44
Table 4.12 Result of Electricity demand for German model of Scenario 3 based on Scenario 2	45
Table 4.13 Result of Electricity demand for Korean model of Scenario 3 based on Scenario 2	46
Table 4.14 Comparison of Electricity demands for heating and cooling per m ² in Scenario 1 and Scenario 2.....	54
Table 4.15 Comparison of Electricity demands for heating and cooling per m ² in Variations based on Scenario 1 with no electricity production.....	56
Table 4.16 Comparison of Electricity demands for heating and cooling per m ² in Variations based on Scenario 2 with no electricity production.....	57
Table 4.17 Comparison of Electricity demands per m ² in Variations based on Scenario 1 with electricity production.....	59
Table 4.18 Comparison of Electricity demands per m ² in Variations based on Scenario 2 with electricity production.....	60
Table 4.19 Comparison of Electricity demands per m ² in Scenario 1 and Variations based on Scenario 2.....	61
Table 4.20 Electricity from PV modules fed into grid and Internal loads in 20 variations..	62

List of Abbreviations and Symbols

PV	Photovoltaic
ELA	Equivalent Leakage Area
SHGC	Solar Heat Gain Coefficient
XPS	Extruded Polystyrene
COP	Coefficient of Performance

1 Introduction

The rapid use of fossil energy after industrialization puts the finite energy at risk of exhaustion, and reckless industrial development has become synonymous with the word environmental pollution. As a result, the world entered into a United Nations Framework Convention on Climate Change (UNFCCC) agreement in 2015 to address the common challenge of global warming. The world is now making various efforts to keep the global temperature rise below 2 degrees increase in comparison to pre-industrial levels [1].

Germany has also set up a climate policy called Climate Action Plan 2050 (2016), which aims to reduce CO₂ emissions. Its target is to reduce CO₂ emissions by about 56% in the total sectors until 2030 [2]. The building sector plan for this policy is to mitigate 72 million tons of CO₂ emissions by about 67% by 2030 compared with 1990 by improving energy efficiency of buildings [2].

In Korea, the Act on Low Carbon Green Growth was enacted and 2030 Korea greenhouse reduction road map revision (2018) was established. The goal of the policies is to decrease 64.5 million tons of CO₂ emissions by 37% compared to Korea's BAU¹ (business as usual) by 2030 and 32.7% in the building sector [3] [4].

To increase the efficiency of the building in line with these goals, it is to reduce the amount of energy used and further produce its own energy. Improvements to the most energy-consuming parts of buildings are required. Insulation of the building itself should be improved through passive design because heating and cooling parts consume almost half of its energy [5]. And energy production in buildings using unlimited renewable energy sources can improve building energy performance and can reduce their carbon footprint.

1.1 Motivation

The motivation of this thesis is to evaluate how the energy efficiency of a typical German and Korean multi-family houses can be enhanced. The research will evaluate the use of semi-transparent and opaque PV modules in the current and renovated states for both models. Each variation can enhance energy performance by reducing and producing energy for heating and cooling. Electricity demands for heating and cooling, electricity production from a few cases of solar modules, and indoor daylight will be investigated. Therefore, the

¹ Forecast of future emissions if no special measures are taken. In other words, estimates of future GHG emissions to be affected by oil price fluctuations, population fluctuations, and economic growth rate, based on the normal growth practices of the national economy.

main goal is to find out the optimal solutions for the German and Korean residential buildings to reduce energy demand and CO₂ emissions.

In short, the study will evaluate the energy performance of each residential building in two countries with different climates and construction cultures and conduct energy simulations of models renovated in high-insulation envelopes and final models with photovoltaic systems. This will analyze and compare the energy simulations of the three stages of the two residential buildings to assess how much energy performance is improved.

2 State of Art Analysis

The state-of-the-art analysis provides an overview of photovoltaics and comparisons between Germany and Korea in terms with construction and energy as well as IDA ICE used for energy simulations in this thesis.

2.1 Photovoltaics

2.1.1 Introduction

Photovoltaic is the technology that generates direct current (DC) electrical power measured in Watts (W) or kilo Watts (kW) from semiconductors when they are illuminated by photons [6]. The solar cell which is the basic component of every photovoltaic plant consists in most cases of silicon, a semiconductor that is also used for diodes, transistors and computer chips (Figure 2.1) [7]. A solar cell is the smallest component of a photovoltaic array and a group of these solar cells are placed on a support frame and are connected electrically to one another to shape a photovoltaic module. Commonly available solar panels vary between several hundred watts and a few kilowatts. A few modules consist of a photovoltaic string in a line to form a photovoltaic string and then a solar array is composed of a few solar strings.

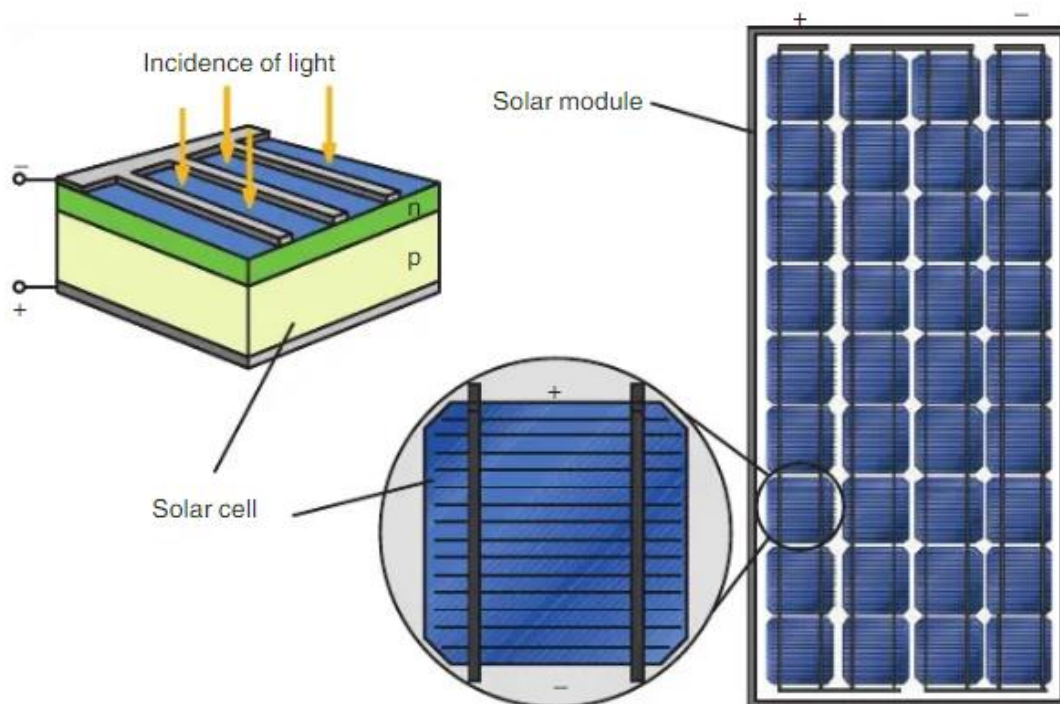


Figure 2.1 Solar cell and module [7]

Figure 2.2 shows the typical PV solar systems of grid-connected and off-grid types. The grid-connected systems consist of an inverter and meters to count the generated electricity

and consumption. The inverter converts the direct current delivered by the modules into alternating current and feeds it into the public grid [7]. The off-grid systems refer to areas without a power grid. They are made up of a charge controller and a power storage device besides an inverter. A charge controller is included between the solar generator and the battery to prevent it from being overcharged or deep discharged [6]. This thesis will focus on grid-connected systems to simulate hourly energy demands for heating and cooling. And the electricity production will be divided into 3 kinds of production such as in-house electricity consumption, electricity fed into the grid, and remaining electricity for heating and cooling.

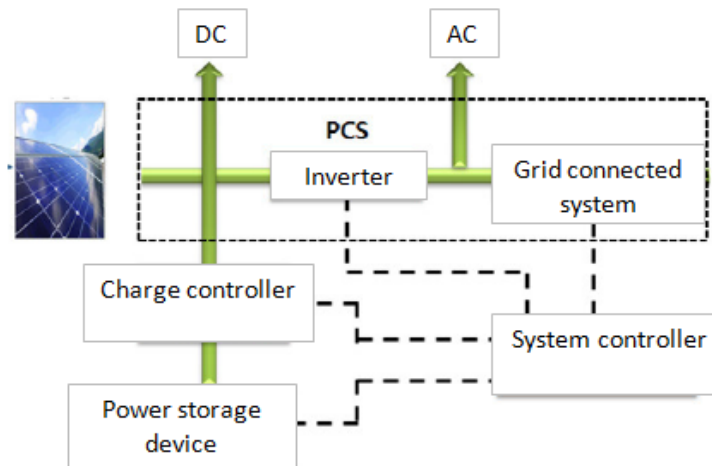


Figure 2.2 PV solar systems [8]

2.1.2 Classifications

PVs are generally classified based on either the active materials (i.e. the primary light-absorbing materials) used for the solar cells or overall device structures [9], as Figure 2.3 and Figure 2.4. PVs are divided into wafer-based and thin-film technologies. Wafer-based PVs are produced from slices of semiconducting wafers derived from ingots [10] and thin-film cells adopt an inherently different approach in which insulating substrates like glass or flexible plastics is used for the deposition of layers of semiconducting materials that will form the device structure [11].

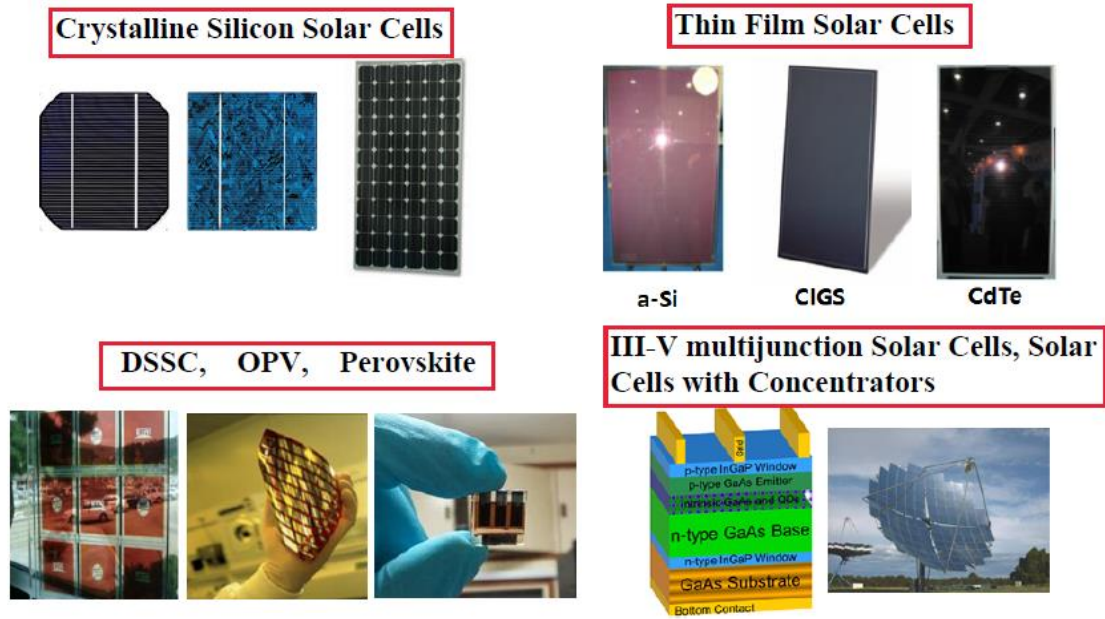


Figure 2.3 Solar cell types according to light absorption layer materials [8]

Most PV technologies that have been deployed at a commercial level have been produced using silicon, with wafer-based crystalline silicon (c-Si) currently the most popular solar cells because it exhibits stable photo-conversion efficiency and can be processed into efficient, nontoxic and very reliable PV cells [12]. C-Si cells as of 2014, still constitute roughly 90% of global module production and are the most developed of all solar cell technologies [13]. This technology will be applied for opaque PV systems in methodology of scenario 3 which will be mentioned in chapter 3.3.4

Thin-film solar cells, along with a relatively simple manufacturing process, can be used for low-cost substrates, such as glass, instead of silicon substrates, to reduce unit costs and their lightweight and flexible features are expected to be beneficial to various product groups such as building exterior materials [8]. Therefore, this thin-film technology will be applied for semi-transparent solar modules for this thesis. Detailed parameters of semi-transparent PV modules applied for this thesis will be introduced in chapter of methodology for scenario 3.

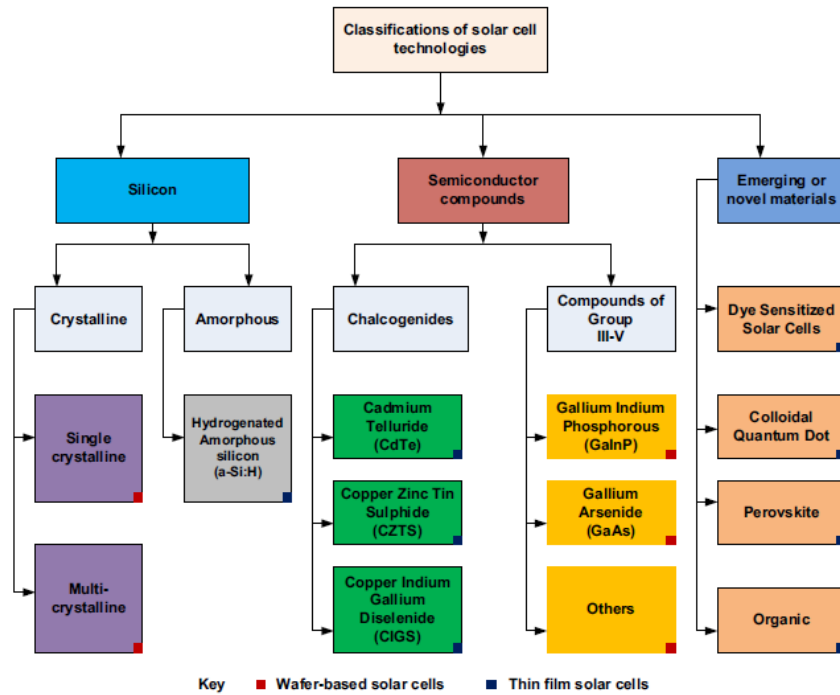


Figure 2.4 Classification of solar cells [9]

Emerging film solar cells offer promising device-level characteristics including visible transparency, high weight-specific power (watts/gram), and novel form factors although their technologies are still at the research and development and early commercialization stage and are yet to be fabricated on a large scale [9].

Table 2.1 shows the summary of photovoltaic types related to details such as characteristics, modules conversion efficiency, and major companies. And it explains if the step is on practical use or research stage at a glance.

Type	Characteristic	Module conversion efficiency	Step	Major companies
mono-Si	<ul style="list-style-type: none"> • Single crystal Si substrate of about 180 μm • Advantages: Performance, Reliability • Task: Lowering Prices 	~20%	Practical use	Hyundai Heavy Industries, LG Shinsung E&G, Sunpower, Panasonic, Motech
multi-Si	<ul style="list-style-type: none"> • Polycrystalline substrates in which small crystals are aggregated • Advantage: Cheaper than single crystal • Task: Lower efficiency than single crystal 	~18%	Practical use	Hyundai Heavy Industries, Hanwha Q CELLS, Trina, JA Solar, Jinko, Kyocera
a-Si	<ul style="list-style-type: none"> • Form an amorphous or microcrystalline Si thin-film on a substrate 	~9%	Practical use	Kaneka, TEL, JS Solar,

	<ul style="list-style-type: none"> • Advantage: Large scale production • Task: Low efficiency 			Next Power, Moserbaer
CIGS	<ul style="list-style-type: none"> • Thin-film type made from Cu, In, Se, etc. • Advantages: Resource-saving, Possibility of mass production and high performance • Task: Large area, amount of In 	~16%	Practical use	WonCIGS, Solar Frontier, Hanergy, Stion
CdTe	<ul style="list-style-type: none"> • Thin-film type using Cd and Te as raw materials • Advantages: Resource saving, Possibility of mass production, low price • Task: Toxicity of Cd 	~15%	Practical use	First Solar
III-V MJ	<ul style="list-style-type: none"> • Compound conjugation with group III and group V elements, condensing technology applied • Advantages: Ultra-high performance • Task: Lowering Prices 	Cell efficiency (~38%)	Re-search stage	BJ power, AnyCasting, Paru, Sharp, Soitec
DSSC	<ul style="list-style-type: none"> • New type of dye adsorbed on TiO₂ absorbs light and develops • Advantages: Possibility of low price • Task: High efficiency, durability 	Cell efficiency (~12%)	Re-search stage	Dongjin Semichem, Sangbo, Eagon, Dyesol, Fujikura
OPV	<ul style="list-style-type: none"> • Thin-film type using organic semiconductor • Advantages: Possibility of low price • Task: High efficiency, durability 	Cell efficiency (~12%)	Re-search stage	Kolon, LG, Heliatek, Mitsubishi, Sumitomo, JX energy
Perovskite	<ul style="list-style-type: none"> • A new type of organic/inorganic compound perovskite that absorbs light and generates power • Advantages: high efficiency and low cost • Task: Durability, large area modularity 	Cell efficiency (~22%)	Re-search stage	KRICT, SKKU, UNIST, Oxford, EPFL

Table 2.1 Efficiency and Characteristics of Solar Cell Types 2018 [8]

2.1.3 Considerations of PV installation

PV modules applied on the windows and walls for this thesis will be installed vertically and those on the roofs have slope from 10° to 16° for maximizing conversion efficiency of PV modules under the limited situation of each roof. The German model has a flat roof while the Korean model has 16° slope of the roofs. According to the degree, electricity production will have different efficiency. So this chapter provides how different efficiency is under a few slopes. Essential elements in installing solar systems are inclination angle, azimuth angle, shading, and module temperature as Table 2.2. These two angles are considered to be the most important factor, as the degree of solar radiation affects the solar system varies widely depending on the angle of incidence and direction. Figure 2.5 indicates the annual power volume is increased in proportion to the solar radiation and the maximum is recorded when the azimuth of the module is facing straight south. Furthermore, Table 2.3

shows comparison of the energy efficiency of the modules according to the three slope angles for a year. After the set of the standard of a module with an angle of incline of 36 degree, this was compared with two solar modules installed parallel and perpendicular to the plane in terms of their advantages and disadvantages and efficiency.

Installation considerations	Highest efficiency conditions
Angle of inclination	30 ° ~35 °
Azimuth	Facing the south
Shading	No shading
Module temperature	25 °C

Table 2.2 Considerations of PV installation [14]

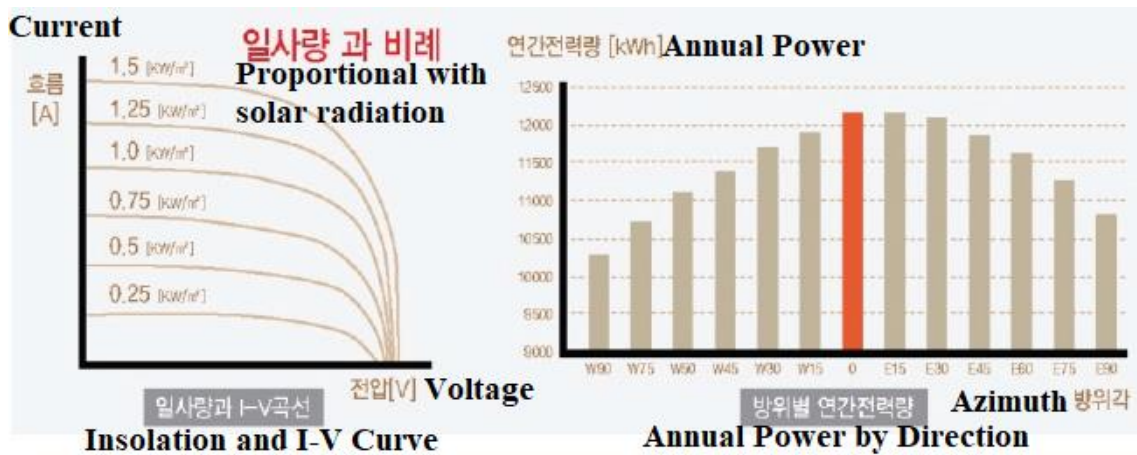


Figure 2.5 Annual power quantity by solar radiation and azimuth [14]

Inclination angle of PV panel	36° (A: Standard for comparison)	0°	90°
Advantage	The highest efficient in 4 seasons	The highest efficient in summer	
Disadvantage	<ul style="list-style-type: none"> • Relatively less efficient in summer • Large support for structural reinforcement 	Lower efficient compared A	The lowest average efficiency in 4 seasons.
Efficiency of annual average	100%	89% (compared with A)	70% (compared with A)
Efficiency during summer	100%	109% (compared with A)	45% (compared with A)

Table 2.3 Comparison of PV panel efficiency according to angles of inclination [14]

The next factor that affects is shading. No matter how efficient the entrance angle and the azimuth angle are, the entire efficiency will be reduced if the solar module is covered due to shading caused by the surrounding buildings. Recently, fine dust has emerged as one of the factors behind shading in Korea. And the last factor is the temperature of the module. In general, power generation decreases by 0.4 to 0.5% each time the temperature of the solar cell rises by 1 K from 25°C [15].

2.2 Comparisons between Germany and South Korea

There are a lot of differences about construction and energy fields between Germany and South Korea. Also, in this regard, through the policies and standards of each country, it is possible to confirm the possibility that both countries can develop in a better direction.

2.2.1 Residential building age

The first object to compare is the age of all residential buildings located in Dresden, Germany and Seoul, Korea. Because the two building models of the study are located in the cities and the energy simulations will be carried out by improving their envelope and energy performance with solar modules. Table 2.4 and Table 2.5 shows specifically the age of the building by when the residential buildings were built. Through Figure 2.6, the percentage of residential buildings constructed at the same time can be compared. The most striking difference is that more than 50% of German buildings were built before 1945, while Korean record does not show how many buildings were constructed before 1945 and only indicates 28% of buildings were built before 1984. On the contrary, 53% of all residential buildings in Seoul have been built since 1990. And residential buildings in Dresden are 37% built at the same time. Through this, the ratio of residential buildings under 30 years is 37% in Dresden and 53% in Seoul.

Dresden	SUM	until 1918	1919- 1945	1946- 1969	1970- 1990	from 1990
SUM	33087	6888	10159	1506	2046	12488
Percent- age	100	20.8	30.7	4.6	6.2	37.7

(unit: %)

Table 2.4 Residential building age in Dresden 2018 [16]

Seoul	Total	Un-known	-1984	1985-1989	1990-1994	1995-1999	2000-2004	2005-2009	2010-2018
Sum	604726	34804	170151	77588	123424	56057	56751	26979	58972
Percentage(%)	100	5.8	28.1	12.8	20.4	9.3	9.4	4.5	9.8

Table 2.5 Residential building age in Seoul 2018 [17]

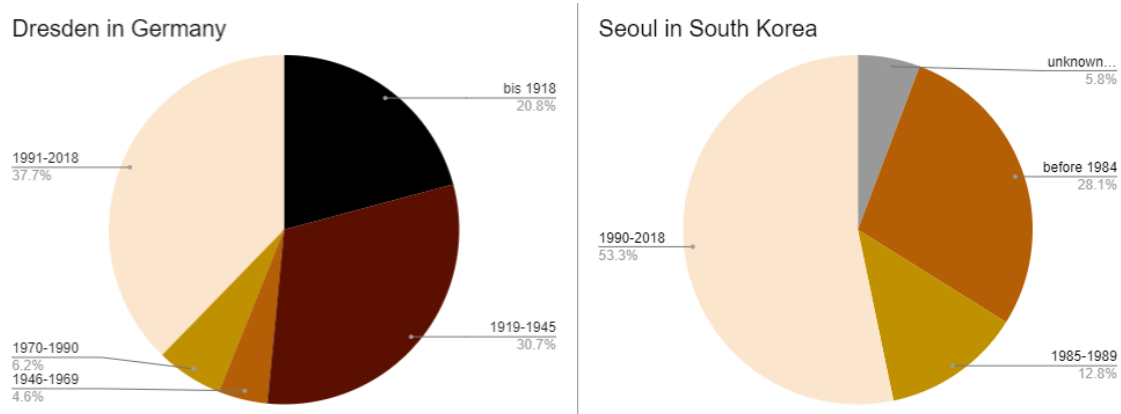


Figure 2.6 Residential building age in Dresden and Seoul [16] [17]

Korean official report ‘Building status statistics’ defines old buildings as buildings over 30 years old [17]. However, in the German tenancy law, buildings built before 1949 are generally defined as old buildings [18]. In other words, residential buildings that are 70 years old or less in Germany and ones that are 30 years or less in Korea can be called new buildings.

2.2.2 Electricity generation by fuel

	Oil	Natural Gas	Coal	Nuclear energy	Hydro electric	Renewables	Other ²	Total
Germany (TWh)	5.2	83.0	229.0	76.1	16.9	209.2	29.3	648.7
South Korea (TWh)	9.1	160.4	261.3	133.5	2.9	21.9	5.1	594.3
Germany (kWh/cap)	62	991	2733	908	202	2497	350	7743
South Korea (kWh/cap)	176	3098	5046	2578	56	426	98	11477

Table 2.6 Electricity generation by fuel 2018 [19]

² Includes sources not specified elsewhere e.g. pumped hydro, non-renewable waste and statistical discrepancies.

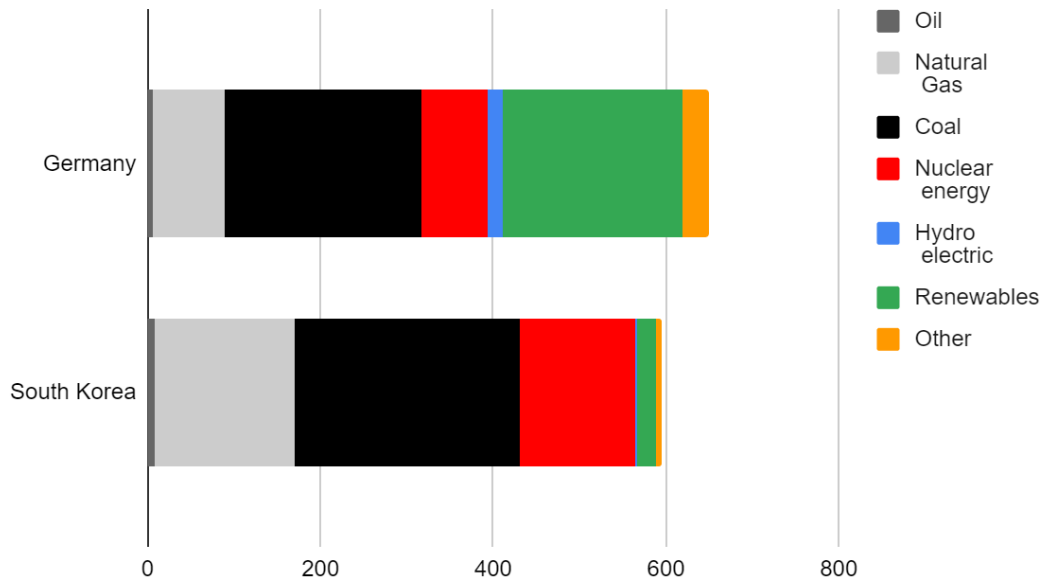


Figure 2.7 2018 Electricity generation by fuel [19]

This introduces electricity generated from the different resources between Germany and Korea. Therefore CO₂ emissions factors are different and the index for each country will be mentioned for calculating CO₂ emissions for both models in chapter of results.

Table 2.6 and Figure 2.7 show the amount of electricity generated by the resources of the two countries. In both countries, the proportion is still more than half that of electricity produced using traditional fossil fuels and nuclear power. The amount of electricity produced using renewable energy sources in Germany is 32 percent and Korean one is 3.7 percent.

2.2.3 Certification systems for buildings

This chapter provides certification system for evaluate energy performance in buildings. So some part of details can be applied for this thesis since the German and Korean models will be renovated with strengthen insulations.

DGNB in Germany and G-SEED in South Korea are standard certification systems for sustainable buildings as Table 2.7. There are various kinds of certification systems in Germany considering energy and environment while there is one integrated certification system in Korea. The scope of compulsory architecture to which these systems are to be applied is not yet widespread. The topics and standards of evaluation factors including energy and environment vary depending on the different types of buildings. The difference in building certification systems between the two countries is the presence or absence of thermal heat bridges. Korean system still considers this criterion as an additional indicator for the highest rating.

Classification	DGNB (Deutsche Gesellschaft für Nachhaltiges Bauen)	G-SEED (Green Standard for Energy and Environmental Design, South Korea)
Evaluation target	All kinds of existing buildings and new construction, interiors, districts	New residential buildings, new non-residential buildings, new detached house, existing residential buildings, existing non-residential buildings, green remodeling residential buildings, green remodeling non-residential buildings
Mandatory target		Public buildings with a total floor area of 3000 m ² or more.
Assessment period	All stages in the life of a building	All stages in the life of a building
Rating	4 (platinum, gold, silver or bronze)	4 (green 1 ~ 4 grade)
Main topics number	6	8 (1 mandatory item for green remodeling residential buildings)
Main topics	<ul style="list-style-type: none"> • Environmental quality • Economic quality • Sociocultural and functional quality • Technical quality • Process quality • Site quality 	<ul style="list-style-type: none"> • Land use and transportation • Energy and environmental pollution • Water circulation management • Maintenance management • Ecological environment • Indoor environment • Housing performance field • Innovative design (additional items)
Differences	<ul style="list-style-type: none"> • Thermal heat bridge as an indicator for evaluation 	<ul style="list-style-type: none"> • Thermal heat bridge as an additional indicator only for the building applying for green 1 and green 2 grade.

Table 2.7 Certification systems for sustainable buildings [20] [21]

Table 2.8 explains the energy performance certification systems of Energieausweis and EEWärmeG in Germany and the Zero Energy Building in South Korea. The scope of mandatory targets of the energy performance certification system is wider than that of the building standard certification system. The German energy performance certification system is mandatory for all buildings with more than a certain area with heating and cooling devices while

the Korean system is gradually expanding its scope. The energy performance established based on the laws of each country is evaluated as the annual primary energy requirement for a building.

Classification	Energieausweis and EEWärmeG 2011 (Germany)	Zero Energy Building (South Korea)
Mandatory target in energy performance field	<p>Energieausweis</p> <ul style="list-style-type: none"> • Residential buildings for living according to their intended purpose, including residential, old people's and nursing homes and similar facilities • Non-residential buildings <p>EEWärmeG 2011</p> <ul style="list-style-type: none"> • All buildings with a usable area of more than 50 m² that are heated or cooled using energy 	<ul style="list-style-type: none"> • Since 2020, Public buildings with a total floor area of 1000 m² or more • Since 2025, Public buildings with a total floor area of 500 m² or more <p>Private buildings with a total floor area of 1000 m² or more</p> <p>Apartment buildings with 30 households</p> <ul style="list-style-type: none"> • Since 2030, All buildings with a total floor area of 500 m² or more
Main criteria	<p>Energieausweis</p> <ol style="list-style-type: none"> 1) 75% of annual primary energy requirement for heating, water heating, ventilation and cooling 2) Maximum values of the specific transmission heat loss related to the heat-transferring surrounding area 3) Annual primary energy requirement calculated with the same method for both the residential building to be constructed and the reference building 4) Requirements of residential buildings for summer thermal insulation. <p>EEWärmeG 2011</p> <ul style="list-style-type: none"> • Covering at least 15 percent of the heating and cooling energy requirements with solar radiation energy 	<ol style="list-style-type: none"> 1) Building energy efficiency certification (annual primary energy requirement) 2) Energy self-sufficiency rate 3) Installation of building energy management system (BEMS) or remote detection electronic meter from all kinds of energy sources <p>(These criteria are the same with 3 specifications of energy and environmental pollution topic in G-SEED.)</p>

Table 2.8 Certification systems for energy performance in buildings [22] [23] [24]

2.2.4 Energy simulation software – IDA ICE

This chapter describes IDA ICE which will be used for energy simulations. IDA Indoor Climate and Energy (IDA ICE) is a new type of simulation tool that takes building performance to another level and accurately models the building, its systems, and controllers – ensuring the lowest possible energy consumption and the best possible occupant comfort [25]

Table 2.9 summarizes features of IDA ICE in terms of simulation solution, complete geometric description, renewable energy systems, and HVAC systems. IDA ICE has functions about almost all renewable energy systems except for building integrated photovoltaics. So there should be an alternative way for energy simulations with semi-transparent. The assumption will be introduced in chapter 3.3.3.

Classification	Contents	IDA ICE
Simulation solution	• Simulation of loads, systems, and solutions	X
	• Iterative solution of nonlinear systems	X
Complete geometric description	• Import and export of simulation models of programs	X
	• Calculation of thermal balance	X
	• Human thermal comfort	X
	• Solar analysis	X
	• Daylighting and lighting controls	X
	• Infiltration and pressure coefficients of a zone	X
Renewable energy systems	• Thermal bridges	
	• Photovoltaics	X
	• Building integrated photovoltaics	
	• Solar thermal	X
	• Wind energy	X
HVAC systems	• Ground source borehole loop system	X
	• HVAC idealized	X
	• Possible configuration of HVAC systems	X
	• Modeling CO ₂	X
	• Forced air unit per zone	X
	• Repetitions cycle air	X

Table 2.9 Features of IDA ICE [26]

3 Methodology

3.1 Research Framework

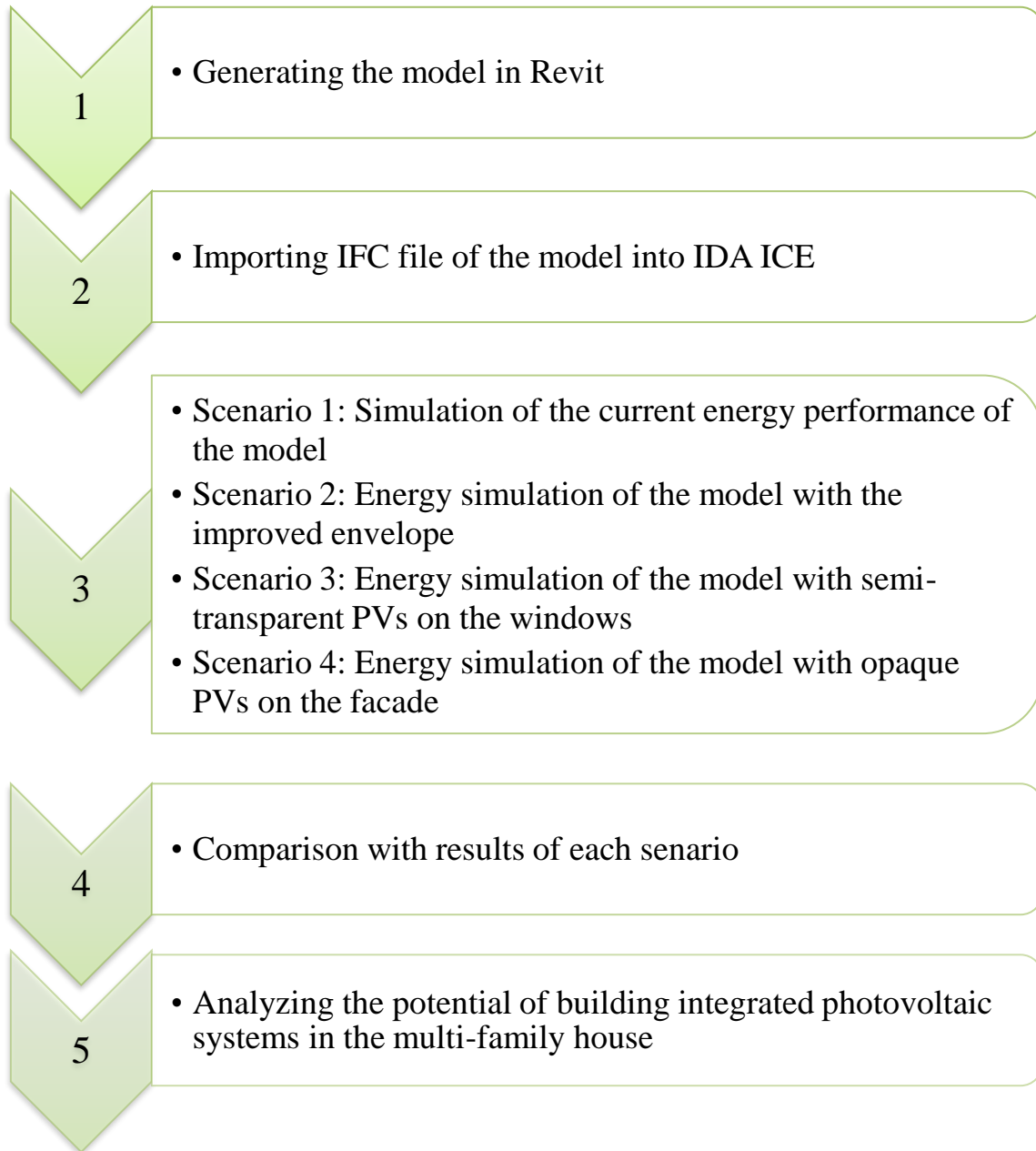


Figure 3.1 Diagram of Process

The progress of this thesis shows as Figure 3.1. The total is divided into 5 procedures and specific energy simulations are carried out in the third stage.

The first step is to create models of multi-family houses in Germany and South Korea in Revit. These two models are the existing residential buildings.

The second step is to import the models transformed as IFC files into IDA ICE. IFC files are compatible into IDA. The German residential building was already present in IDA ICE and the Korean building will be imported.

The third step is based on four scenarios. Simulating the energy performance of the current initial state, performing the energy simulation of the model with the improved envelope, then installing transparent solar modules in the windows to execute the energy simulation. Finally, opaque solar modules are installed on the facade to evaluate energy performance.

The fourth step compares and analyzes the results of each scenario related to heating load, energy consumption, carbon dioxide emissions.

The final step is to find out which scenario is the most optimized solution to maximize energy performance.

3.2 Case Study Models

There are 2 models from Germany and South Korea. The German model is located in Dresden and the Korean one is in Seoul.

3.2.1 German Residential Building

The German residential building is a 6-storey (and additional basement) and stair type multi-family house built in the period of 1960s ~ 1990s as Figure 3.2. There are 3 flats on each floor in Figure 3.2. The gross area of the first flat with 2 rooms, a living room, and a bathroom and a kitchen with a hall is 63.96 m², the second area with same 6 zones is 63.44 m², and the last one with 6 zones is 53.92 m².

- The front of the building is south facing but only 2 flats are influenced by this orientation and the other one is north-west facing.
- Not all shading systems in the balconies exist outside the building. 2 flats facing south have one shade for a window in the living room, while the other one has one shade for two windows.

- There is a water radiator system for each household.



Figure 3.2 German Multi-family House and Floor Plan [27]

There is no mechanical ventilation controlled by the center and only natural ventilation through openable windows and exhaust fans in the kitchen and the bathroom.

3.2.2 Korean Residential Building

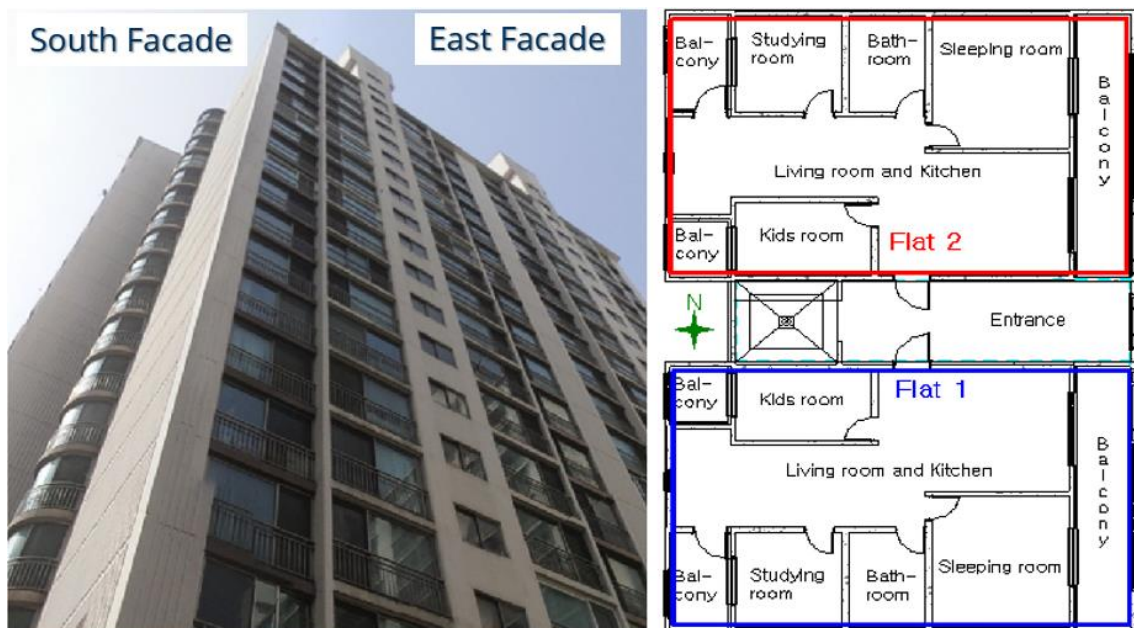


Figure 3.3 Korean Multi-family House and Floor Plan [28] [29]

Figure 3.3 shows the front of the typical Korean apartment building constructed in 1999. This is a 20-storey and stair type residential building mirrored at the stairs room. There is 19-storey according to the German way to count levels of a building. The gross area of one flat for the private place is 79.7 m² and the total area included with the private and public places such as stairs, halls, and elevators for one flat is 105.6 m² by two ways to measure the house area in Korea.

- The front of the building is east facing.
- No shading system exists outside the building and blinds or curtains are installed inside the window personally.
- There is a heating floor system and a central heating system for each household.
- There is no artificial ventilation system controlled by the center and only natural ventilation through openable windows and exhaust fans in the kitchen and the bathroom.
- Large sliding windows such as curtain walls with safety railings were installed on the front balconies.

3.3 Energy Simulation Scenarios

3.3.1 Scenario 1 – Existing Residential Buildings

Scenario 1 suggests undertaking an energy simulation for the existing state of both residential buildings. The aim of these simulations is to determine the energy efficiency of the buildings on the first step. All zones of the buildings including basements and roofs will be simulated for annual heating and cooling loads. This first scenario is the standard that will be compared to the other scenarios following.

The simulations determine the 3 parameters below.

- Cooling load of the buildings.
- Heating load of the buildings.
- Energy consumption of the buildings.

Location and Meteorological Data

The meteorological data for both models are from ASHRAE Fundamentals 2013 in IDA ICE as Table 3.1. The coordinates of the site location are taken from Google earth. These data include details on various climatic factors at this place for each hour. From the data, detailed weather information is shown in the tables below, such as temperature, cloud, etc. in IDA ICE (Table 3.2 and Table 3.3).

Location	Type	Germany	Korea
Site Location	Latitude	50.57 N°	37.32 N°
	Longitude	13.59 E°	126.57E°
	Elevation above sea level	231m	53m
Weather Data	from ASHRAE Fundamentals 2013		
Winter weather data	Dry-bulb min	-13.60°C	-11.10°C
	Dry-bulb max	-7.90°C	-4.60°C
	Wet-bulb max	-8.70°C	-6.60°C
	Wind direction	160°	290°
	Wind speed	1.80m/s	2.70m/s
Summer weather data	Dry-bulb min	16.70°C	24.40°C
	Dry-bulb max	29.90°C	32.30°C
	Wet-bulb max	18.80°C	24.60°C
	Wind direction	260°	270°
	Wind speed	2.80m/s	2.80m/s
Clear-sky optical depth	Winter tau_b	0.338	0.399
	Winter tau_d	2.389	2.196
	Summer tau_b	0.37	0.446
	Summer tau_d	2.303	2.227

Table 3.1 Location and Weather data input

Germany	Variables							
	Dry-bulb temperature in Germany, Deg-C	Rel humidity of air in Germany, %	Direct normal rad in Germany, W/m2	Diffuse rad on hor surf in Germany, W/m2	Wind speed, x-component in Germany, m/s	Wind speed, y-component in Germany, m/s	Cloudness in Germany, %	Clearness in Germany, % (100%-Cloudness)
January	0.1	80.8	29.1	21.6	1.5	1.8	79.9	20.1
February	-0.2	84.6	61.5	36.4	0.1	0.9	58.7	41.3
March	3.8	73.3	83.4	59.4	-0.5	1.8	65.3	34.7
April	8.1	69.6	122.7	91.5	0.5	-0.1	63.2	36.8
May	13.6	67.7	155.2	110.2	0.9	0.5	50.8	49.2
June	16.6	70.8	101.5	132.8	1.2	0.7	72.7	27.3
July	18.3	68.6	147.1	118	1.2	0.5	57.4	42.6
August	18.2	67.7	161.1	95	1.7	0.8	53.4	46.6
September	14.2	74.4	95.8	75.7	2.1	1.1	62.3	37.7
October	10.1	73.8	107.6	45	-0.4	2	51.6	48.4
November	2.4	82.6	40.6	24.7	1.5	0.1	75.9	24.1
December	0.6	81	33.5	16.5	1	1.4	71.7	28.3
mean	8.9	74.5	95.1	68.9	0.9	1	63.5	36.43

Table 3.2 Weather data in Germany

Korea	Variables							
	Dry-bulb temperature in Korea, Deg-C	Rel humidity of air in Korea, %	Direct normal rad in Korea, W/m2	Diffuse rad on hor surf in Korea, W/m2	Wind speed, x-component in Korea, m/s	Wind speed, y-component in Korea, m/s	Cloudness in Korea, %	Clearness in Korea, % (100%-Cloudness)
January	-2.5	61	90.9	48.6	1.4	-0.3	36.8	63.2
February	0.7	60.7	108.1	63.6	1.7	-0.8	38.8	61.2
March	5.9	62.1	140.6	83.6	1.2	0.2	38.6	61.4
April	13.2	54	197.1	94	1.9	0.4	42	58
May	18.1	63.4	179.5	104.4	1.3	0.4	53.7	46.3
June	21.8	68.8	122.4	113.1	0.8	0	59.6	40.4
July	24.5	79.1	78.9	117	0.5	-0.1	68.6	31.4
August	26	73.8	85.8	109.5	-0.2	-0.3	63.9	36.1
September	21.2	69.9	111.7	88.2	0	-0.4	52.4	47.6
October	15.1	64	123.3	73.6	0.2	-0.7	48.2	51.8
November	7.3	61.3	111.4	53.2	0.8	-0.6	34.8	65.2
December	0.9	60.7	89.5	46.8	1.1	-0.7	33.1	66.9
mean	12.7	65	119.8	83.1	0.9	-0.2	47.6	52.46

Table 3.3 Weather data in Korea

Figure 3.4, Figure 3.5 and Figure 3.6 show the differences between the two values at a glance in terms with temperature and humidity, direct normal radiance and sky clearness from Table 3.2 and Table 3.3.

The temperature range between the lowest and highest temperatures in Korea is larger than in Germany so the demand for heating and cooling loads is expected to be higher. German humidity is higher than the annual average from November to February, while Korea has higher humidity than average between June and September. This is because the rainy seasons in Germany and Korea are different from winter and summer, and Korea is also very humid from August to September due to a few typhoons. The effects of this humidity will add more to the rise and fall of temperature within Korean and German models.

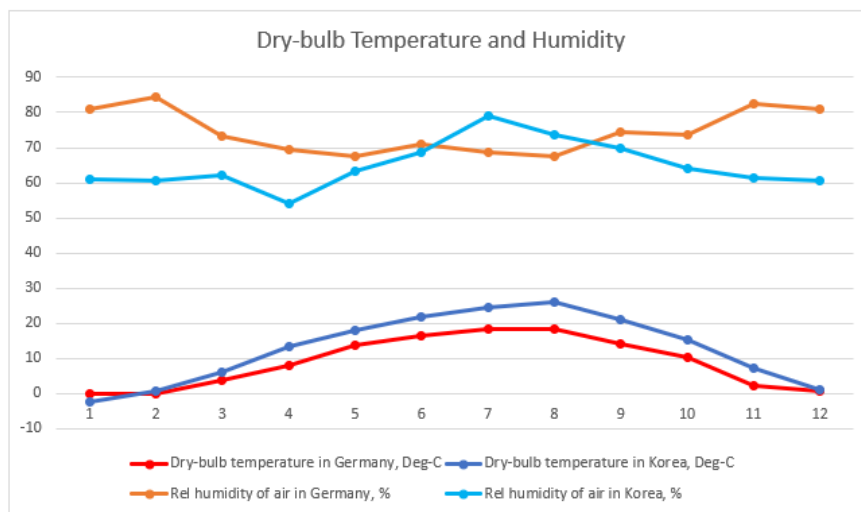


Figure 3.4 Dry-bulb Temperature and Humidity of Germany and Korea

The values of Korean solar radiance and sky clearness are overall higher than those of Germany. Due to the climatic influence, radiance and sky clearness in Germany are plentiful in summer when air is dry and sunlight is high, while springtime is high in Korea, which is not the rainy season and the sun is strong. These two values will greatly affect the temperature through the windows, which will influence not only heating and cooling demands but also electricity production amount in Scenario 3 and 4.

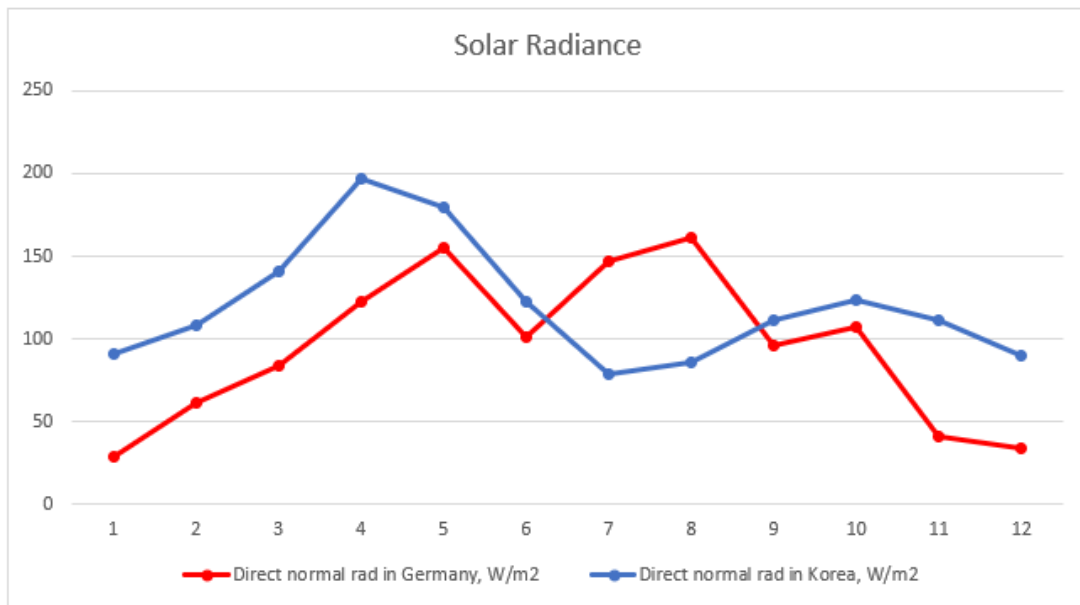


Figure 3.5 Solar Radiance of Germany and Korea

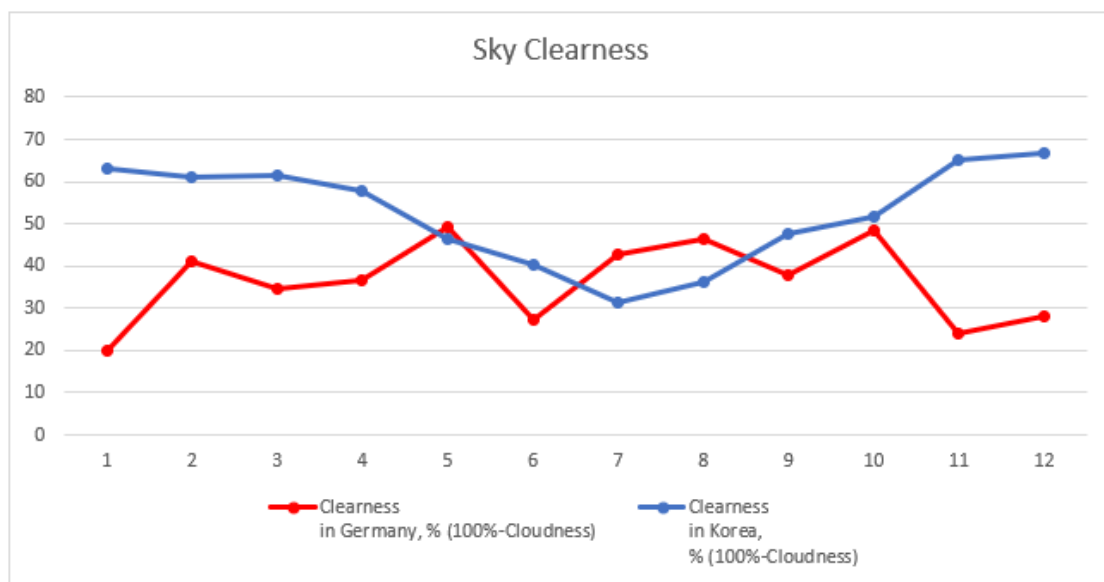


Figure 3.6 Sky Clearness of Germany and Korea

Activity Data

Table 3.4 shows the activity data input of the buildings. Except for the total floor area, wind profile, and pressure coefficients, other activity values are the same. Internal load is assumed in a simplified manner with constant 4.17 W/m^2 for the hourly internal gain of equipment including lights and occupants in accordance with DIN 4108-2 (2013). Unheated stairs, balconies, basements, and roofs are excepted. The German model is located in the suburban, while the Korean model is in the center of the city. Thus, the value of the wind profile is different. Since the pressure coefficients values are determined by the angle and height of the exterior walls and roofs, the two buildings with different appearances have different values. The value of air exchange per hour is simplified assumed to be 0.3 h^{-1} . Other values are default values in IDA ICE.

Activity	Type	Value	
		Germany	Korea
Reference Floor Area		1600.36 m ²	4873.62 m ²
Internal gain	Equipment including occupants and lights (always on)	4.17 W/m ²	
Heating and Cooling Efficiency		100%	
Environmental Control	Heating Setpoint temperature	22°	
	Cooling Setpoint temperature	26°	
Ventilation	Air handling unit	No central AHU	
Thermal bridges of total envelope	Overall internal insulation	0.1 W/m ² K	
Infiltration	Air changes per hour (building)	0.3 ACH	
Wind profile	Coefficient in power law expression for wind speed	0.67	0.47
	Exponent in power law expression for wind speed	0.25	0.35
Pressure coefficients	Exterior wall (semi exposed)	-0.6 ~ 0.2	-0.6 ~ 0.2
	Roof (semi exposed)	-0.1	-0.6 ~ -0.45
Window frame absorptance		0.5	
Exponent in leak power law	i.e. doors	0.6	
Cd factor in flow for large openings	i.e. doors	0.65	
All doors and windows		Closed	

Table 3.4 Activity Data of Germany and Korea

There are definitions in IDA ICE for understanding Table 3.4.

- Heat setpoint temperature: The heating setpoint for this zone. The displayed setpoint may be overridden by a zone control macro.
- Cool setpoint temperature: The cooling setpoint for this zone. The displayed setpoint may be overridden by a zone control macro.
- Equipment: The sensible power emitted by the equipment in the zone per square meter of floor area (ignoring the equipment schedules). This column is editable for zones with a single "Equipment" object.
- Thermal bridges: Coefficients for calculation of loss factors for thermal bridges in zones
- Infiltration: Method and parameters for building air leakage
- Pressure coefficients: Coefficients for calculation of wind pressure on external surfaces of the building

Construction Data

There are structural components of German and Korean models (Table 3.5). Overall, the more recently built Korean buildings have a slightly better U-value and especially, heat transfer coefficients of the floors and ceilings are much lower than the German ones. The large panel elements of the German model have a thin insulation layer between 2 reinforced concrete layers while the exterior walls of the Korean model include 2 different internal insulations inside the reinforced concrete layer. The exterior balconies were constructed in different ways. The balconies in the German building are protruded to the outside of the building, while Korean balconies were built as part of the building. Even at the same U-value, the balconies in the German buildings commonly do not have windows but Korean balconies have. As a result, the Korean balconies are separated zones with a heat storage capacity but the German balconies only play the role of shading. The interior walls are usually 15 cm thick and have no additional insulation layer for the two models. The floor components have one layer of insulation on the ground floor in the German model, while the Korean model has three insulation layers. This is because there is an additional layer for a floor heating system in Korea. That's why the floor insulation in the Korean model is more reinforced compared to the German model. And the biggest differences are the components of ceilings and floors. The difference of the heat transmission coefficient between 2 buildings is 2.4 W/m²K and the reason is the same as the reason mentioned above. Traditionally, all residential houses in Korea have floor heating systems but Germany mainly uses radiator distribution systems for old building types. The ceiling components of apartments on the top floor of Korea also have lower heat transmission with thicker insulation layers. The components of the roof have almost similar heat transmission. The windows are double glazing for both models but the whole U-value including the frame and glazing is lower in the Korean model. The Korean details of glazing are assumed from another apartment plan [30].

Component	German Model			Korean Model		
	Name	Thickness (cm)	U-value (W/m ² K)	Name	Thickness (cm)	U-value (W/m ² K)
Exterior walls (from wall inside)	Sandwich panel elements: 14 cm Reinforced concrete 6 cm Mineral wool 6 cm Reinforced concrete	26	0.60	0.9 cm Gypsum board 5 cm XPS class 3 15 cm Reinforced concrete	20.9	0.53
Exterior Balcony walls (from wall inside)	15 cm Reinforced concrete	15	4.30	15 cm Reinforced concrete	15	4.30
Interior walls	mainly 15 cm and a few 7 cm Reinforced concrete	15 or 7	4.30	15 cm Reinforced concrete	15	4.30
Interior walls insulated connects to stairs (from wall inside)	15 cm Reinforced concrete	15	4.30	0.9 cm Gypsum board 5 cm XPS class 3 15 cm Reinforced concrete	20.9	0.53
Basement ceiling / Ground floor (from the top)	0.5 cm Impact sound insulation/flooring 5 cm Anhydrite screed 2.5 cm Mineral wool 14 cm Prestressed concrete	22	1.20	0.5 cm Polyvinyl chloride sheet 5 cm Cement mortar 7 cm Aerated concrete 13.5 cm Reinforced concrete 5 cm Mineral wool	31	0.47
Ceilings / Floor (from the top)	0.5 cm Impact sound insulation/flooring 3 cm Anhydrite screed 14 cm Prestressed concrete	17.5	3.60	0.5 cm Polyvinyl chloride sheet 5 cm Cement mortar 7 cm Aerated concrete 13.5 cm Reinforced concrete 0.9 cm Gypsum board	26.9	1.25
Balcony ceiling / floor (from the top)	15 cm Reinforced concrete	15	4.30	13.5 cm Reinforced concrete	13.5	4.40
Top-floor ceiling (from the top)	14 cm Prestressed concrete 6 cm Mineral wool	20	1.00	0.5 cm Floor coating 15 cm Reinforced concrete 8 cm Mineral wool 0.9 cm Gypsum board	24.4	0.40
Roof (from the top)	4 cm Reinforced concrete 1.2 cm Waterproofing	5.2	3.90	0.5 cm Metal shingle 13.5 cm Reinforced	14	4.00
Windows	Double glazing		U _w = 2.8 W/m ² K, g = 0.75	Double glazing		U _w = 1.8 W/m ² K, g = 0.75

Table 3.5 Structural components of the German and Korean Models [27] [29]

3.3.2 Scenario 2 – Retrofitting with Additional Insulations and Systems

Scenario 2 proposes to retrofit the models with additional insulations and systems. They will be installed for better energy performances compared to the results of initial models according to German energy-saving standard for version 2014 (BRD 2013) and Korean standards for energy saving in buildings. U-values for the construction components in the

models will be lower as much as the minimum limits of the standards because this thesis aim is not to find out the best thermal performance with the maximum envelope.

All data information was the same for position data, operation data as Scenario 1 except for construction data.

Construction Data

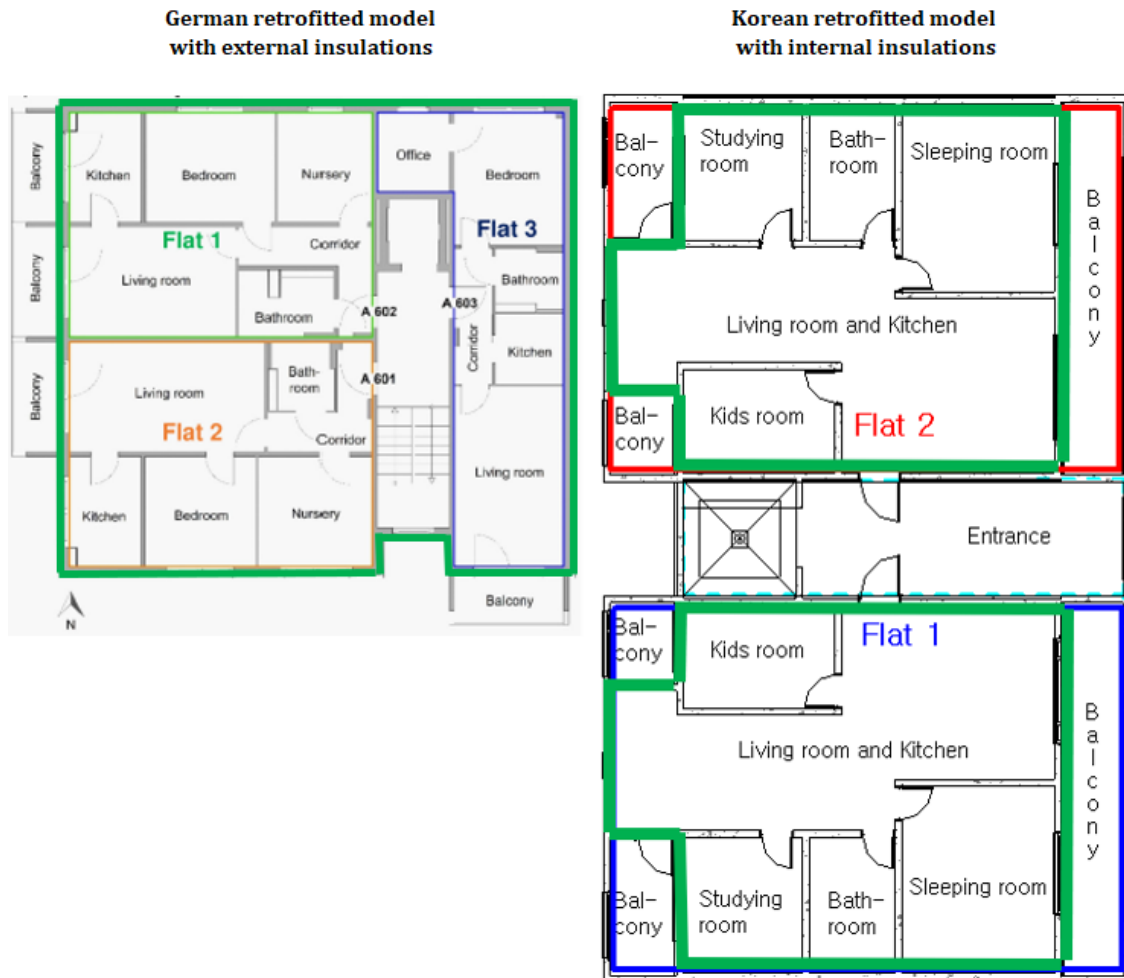


Figure 3.7 Floor plans of German and Korean models retrofitted [27] [29]

Figure 3.7 indicates floor plans for German and Korean models renovated with additional insulations. The German building is refurbished with external insulations while the Korean one is changed with internal insulations without balconies and stair zones. Because the existing external walls covered all closed zones are insulated in the German model and the building has six floors, which is low in height, it is not complicated that the renovation with the new external insulations, but since all external walls surrounding the Korean model are not insulated and the building has 20 floors, the renovation with internal insulations is more suitable and easier for the site than external insulations.

- German Model

As mentioned above, the exterior walls of the German model are insulated with additional mineral wool. And the ceiling of the basement and ground floor and the ceiling of the top floor were also added with insulations. Above all, windows whose heat transmittance was the worst were all replaced by triple windows.

German Model	Scenario 1 - Initial Model			Scenario 2 - Retrofitted Model		
	Name	Thickness (cm)	U-value (W/m ² K)	Name	Thickness (cm)	U-value (W/m ² K)
Exterior walls (from wall inside)	Sandwich panel elements: 14 cm Reinforced concrete 6 cm Mineral wool 6 cm Reinforced concrete	26	0.60	Sandwich panel elements: 14 cm Reinforced concrete 6 cm Mineral wool 6 cm Reinforced concrete 10 cm Mineral wool	36	0.20
Exterior Balcony walls (from wall inside)	15 cm Reinforced concrete	15	4.30	15 cm Reinforced concrete	15	4.30
Interior walls	mainly 15 cm and a few 7 cm Reinforced concrete	15 or 7	4.30	mainly 15 cm and a few 7 cm Reinforced concrete	15 or 7	4.30
Interior walls insulated connects to stairs (from wall inside)	15 cm Reinforced concrete	15	4.30	15 cm Reinforced concrete	15	4.30
Basement ceiling / Ground floor (from the top)	0.5 cm Impact sound insulation/flooring 5 cm Anhydrite screed 2.5 cm Mineral wool 14 cm Prestressed concrete	22	1.20	0.5 cm Impact sound insulation/flooring 5 cm Anhydrite screed 2.5 cm Mineral wool 14 cm Prestressed concrete 10 cm Mineral wool	32	0.27
Ceilings / Floor (from the top)	0.5 cm Impact sound insulation/flooring 3 cm Anhydrite screed 14 cm Prestressed concrete	17.5	3.60	0.5 cm Impact sound insulation/flooring 3 cm Anhydrite screed 14 cm Prestressed concrete	17.5	3.60
Balcony ceiling / floor (from the top)	15 cm Reinforced concrete	15	4.30	15 cm Reinforced concrete	15	4.30
Top-floor ceiling (from the top)	14 cm Prestressed concrete 6 cm Mineral wool	20	1.00	14 cm Prestressed concrete 6 cm Mineral wool 14 cm Mineral wool	34	0.22
Roof (from the top)	4 cm Reinforced concrete 1.2 cm Waterproofing	5.2	3.90	4 cm Reinforced concrete 1.2 cm Waterproofing	5.2	3.90
Windows	Double glazing		U _w = 2.8 W/m ² K, g = 0.75	Triple glazing		U _w = 1 W/m ² K, g = 0.5

Table 3.6 Renovation detail for the German model [27]

- Korean Model

The Korean model has renovated internal insulations surrounding one flat with the exception of the balconies and stairs zones. Stairs and balconies in the Korean building ordinarily were not insulated so the zones will not be improved by additional insulation layers [30]. Mineral wool against fire is used for the inside insulation layer in Figure 3.7 and the additional inside finish layer is needed but the last layer will not be considered because it does not have a significant impact on U-value.

The ceiling of the basement and ground floor and the ceiling of the top floor were also modified through additional insulations. Also, floors and ceilings on each floor have been added, unlike the German model. The windows faced outside were changed to high-performance windows compared to the windows which don't face outside.

Korean Model	Scenario 1 - Initial Model			Scenario 2 - Retrofitted Model		
	Name	Thickness (cm)	U-value (W/m ² K)	Name	Thickness (cm)	U-value (W/m ² K)
Exterior walls (from wall inside)	0.9 cm Gypsum board 5 cm XPS class 3 15 cm Reinforced concrete	20.9	0.53	11 cm Mineral wool 0.9 cm Gypsum board 5 cm XPS class 3 15 cm Reinforced concrete	31.9	0.20
Interior walls insulated connects to stairs (from wall inside)	0.9 cm Gypsum board 5 cm XPS class 3 15 cm Reinforced concrete	20.9	0.53	5.5 cm Mineral wool 0.9 cm Gypsum board 5 cm XPS class 3 15 cm Reinforced concrete	26.4	0.29
Basement ceiling / Ground floor (from the top)	0.5 cm Polyvinyl chloride sheet 5 cm Cement mortar 7 cm Aerated concrete 13.5 cm Reinforced concrete 5 cm Mineral wool	31	0.47	0.5 cm Polyvinyl chloride sheet 5 cm Cement mortar 7 cm Aerated concrete 13.5 cm Reinforced concrete 0.9 cm Gypsum board 5 cm Mineral wool 7 cm Mineral wool	38	0.24
Ceilings / Floor (from the top)	0.5 cm Polyvinyl chloride sheet 5 cm Cement mortar 7 cm Aerated concrete 13.5 cm Reinforced concrete 0.9 cm Gypsum board	26.9	1.25	5 cm Cement mortar 7 cm Aerated concrete 13.5 cm Reinforced concrete 0.9 cm Gypsum board 1.6 cm Mineral wool	28.5	0.80
Top-floor ceiling (from the top)	0.5 cm Floor coating 15 cm Reinforced concrete 8 cm Mineral wool 0.9 cm Gypsum board	24.4	0.40	0.5 cm Floor coating 15 cm Reinforced concrete 8 cm Mineral wool 0.9 cm Gypsum board 8 cm Mineral wool	32.4	0.21
Windows	Double glazing		U _w = 1.8 W/m ² K, g = 0.75	Double glazing on the exterior walls		U _w = 1.2W/m ² K
				Double glazing on the interior walls		U _w = 1.6W/m ² K

Table 3.7 Renovation detail for the Korean model [29]

Advantages and Disadvantages

This renovation details have both advantages and disadvantages.

Advantage:

- Lower U-value
- More saving-energy performance
- Enhanced indoor thermal resistance

Disadvantage:

- The initial cost is relatively high.
- The Korean model has a reduced living volume due to the additional internal insulations.

3.3.3 Scenario 3 – Semi-transparent Photovoltaics Installation on Windows

Scenario 3 suggests installing semi-transparent photovoltaics on windows. Additional insulations alone have limitations in improving energy performance. Not only reducing energy use but also producing energy itself is a model for a more advanced form of the future society in terms of reducing carbon dioxide emissions. If translucent solar modules are installed on the surface of the windows to prevent excessive sunlight and produce electricity, it would be nicer. Although the energy efficiency of translucent solar cells in commercial use is only one-third compared with that of opaque cells, the plan is to maximize energy production using all available resources in buildings.

There are two energy simulations with semi-transparent PV modules for both the initial state and the renovated state of the German and Korean buildings. In other words, total of 4 simulations are conducted based on Scenario 1 and Scenario 2 for each building.

The aim of Scenario 3 is:

- ① To evaluate the electricity values produced by the semi-transparent PV modules.
- ② To calculate the heating and cooling energy demands of the models integrated with semi-transparent PV modules.
- ③ To choose the solar grid system between grid-connected and off-grid systems.
- ④ To analyze how the daylighting in the models with semi-transparent PV modules is changed compared to the previous models.

The semi-transparent photovoltaic cells as a thin-film form are designed to be laminated in the windows. Thus, g value and transmittance of the windows with the semi-transparent solar cells will be lower with those of the initial windows. Through using of solar radiance

to the façade for free, the cooling energy demands will be expected to decrease. But the indoor lighting level can be lower so comparing for both the previous and last models in terms with installing of semi-transparent PV modules

Chosen Semi-transparent Solar Cell Model and Parameters

The chosen solar model is a cadmium telluride (CdTe) photovoltaic module in Table 3.8. The efficiency of the chosen solar panel is 6.44% but there will be some loss when it works. So, 6% of the module efficiency is assumed and 50% of transparency is used for not reducing a lot of daylight.

PV Type	Cadmium Telluride (CdTe)
Efficiency (%)	6
Transparency (%)	50
Power Pmax (W)	40
Open Circuit Voltage (Voc)(V)	116
Short Circuit Current (Isc)(A)	0.49
Max Power Voltage (Vmpp)(V)	87
Max Power Current (Impp)(A)	0.46

Table 3.8 Chosen Semi-transparent Solar Module [31]

Table 3.9 shows the parameters for semi-transparent PV modules. The only windows facing south in the German model can be used for installing solar modules below because opening balconies surround the other windows. The Korean model has a huge area facing east as well as west for PV. The windows facing west are hidden from the sun by neighbor buildings realistically. But note that there are no surrounding buildings to study all available resources for electricity generation. IDA ICE used for the simulations asks degree of orientation measured from the south so the value of south facade is 0° and the east façade has 270° and the west one has 90° of the value. Total electricity generated by the whole buildings will be calculated to multiply the total PV area and electricity production per 1 m². The explanation for other values is in Assumptions.

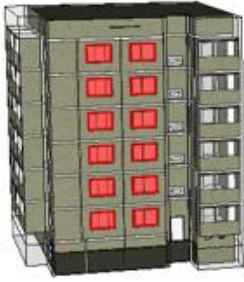
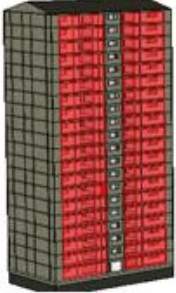

Parameters	German Model	Korean Model	
	South	East	West
			
Tilt	90° (Vertical)		
Orientation (from the south)	0°	270°	90°
Solar data	Dresden	Seoul	
g value of glazing	value in the initial and retrofitted model * 0.5		
Transmittance level of glazing	value in the initial and retrofitted model * 0.5		
PV area	1 m ²		

Table 3.9 Parameters for Semi-transparent PV

Assumptions

As mentioned in chapter 2.2.4, IDA ICE does not have the function applied for semi-transparent PV yet. Therefore, SHGC which represents solar radiation transmittance is assumed as the value which is calculated by multiplying both the g value of the windows and 50% of transparency of the solar module for evaluating the heating and cooling energy demands. Because the exact g value was not provided in the specification. And semi-transparent solar cells will be laminated on the existing windows so the total transparency is also multiplied the initial transparency and 0.5 of semi-transparent PV. Table 3.10 indicates parameters for the glass construction applied to this assumption.

Glass construction	Type	Initial value	value with semi-transparent PV module
Double glazing window	g, Solar Heat Gain Coefficient	0.76	0.38
	T, Solar transmittance	0.7	0.35
	T _{vis} , Visible transmittance	0.81	0.405
Triple glazing window	g, Solar Heat Gain Coefficient	0.5	0.25
	T, Solar transmittance	0.45	0.225
	T _{vis} , Visible transmittance	0.7	0.35

Table 3.10 Parameters of g value and Transmittance with Semi-transparent PV

This assumed g value affects areas with the integrated windows regarding heating and cooling energy requirements. However, the area of the windows applied in the German model is not large and the windows installed in the Korean model are connected with the balconies. No significant error due to this g value assumption is expected in terms of heating and cooling energy requirements since the areas of all balconies are not heated and cooled.

Chosen Grid-connected PV System for using electrical energy

The Grid-connected PV system is chosen to use the electrical energy produced from the semi-transparent solar modules, which is displayed in Figure 2.2 of chapter 2. Because the two buildings are located in the cities where is connected to the central grid without problems. How a grid-connected solar power system works is showed below.

- Solar photovoltaic cells take direct current electricity from the sun.
- An inverter converts the output of DC from solar modules to alternating current electricity.
- AC electricity is used for in-house consumption.
- Surplus power is fed back into the grid.

Thus, the annual electrical energy in the buildings is identified by an hour and compared to the hourly electricity demand for heating and cooling. And then there will be 3 kinds of electricity; electricity from PV systems used in the buildings for heating and cooling and feeding into the grid as well as the remaining electricity demand from the grid for heating and cooling. These three types occur according to the usage of electricity because PVs produce more than the internal gain between sunrise and sunset when the solar energy is generated, and additional electricity is needed when no electricity is produced at night.

Advantages and Disadvantages

This installation of semi-transparent PV has both advantages and disadvantages.

Advantages

- Electricity production as well as works in low light levels if the sunlight is enough strong before.
- Saving cost for purchasing electricity power
- Reducing solar heat gain in summer
- PV cells are integrated on the glazing

Disadvantages

- Expensive cost for installing
- Much lower energy conversion efficiency compared to opaque PV modules.
- Reducing solar heat gain in winter

3.3.4 Scenario 4 – Opaque Photovoltaics Installation on Walls

Scenario 4 is for maximizing the electricity generated from opaque solar modules. The conversion efficiency of Semi-transparent PV panels is the only one third of opaque ones. So the electrical energy will not be enough for the models. Additional electrical energy should be generated for saving energy.

There are also two energy simulations with opaque PV modules for both the initial state and the renovated state of the German and Korean buildings. But opaque photovoltaics do not influence on energy demands for heating and cooling for the models because they are installed on the opaque walls and roofs, neglecting the shading effects and thus the lower temperature at the building component surface. So the results of energy simulations are the same as those of Scenario 1 and Scenario 2.

Chosen Opaque Solar Cell Model and Parameters

Table 3.11 indicates the properties of the chosen opaque solar cell module. Photovoltaic type is monocrystalline and N-type which means that it uses an N-type semiconductor with more electrons than positive holes [32]. The conversion efficiency of the chosen opaque solar module is 21.4% but 20% is assumed because of its junction loss.

PV Type	Monocrystalline / N-type
Efficiency (%)	20
Transparency (%)	0
Power Pmax (W)	370
Open Circuit Voltage (Voc)(V)	42.8
Short Circuit Current (Isc)(A)	10.82
Max Power Voltage (Vmpp)(V)	37
Max Power Current (Impp)(A)	10.01

Table 3.11 Chosen Opaque Solar Module [33]

There are parameters for opaque PV in Table 3.12. Total 5 energy simulations for determining the electrical energy per 1 m² in the ways of the different slopes and orientations for 2 buildings. The areas of walls below are chosen because of continuous walls without windows. The energy output produced from walls facing both south and west in the German model will be integrated into the result part. The walls facing east in the German model are not taken into account because of the connection to a neighbor building. The extra roof area is also considered for 2 models. Although the roof in the German model needs a structural test so as to install PV modules on the 4 cm of the thin roof layer, it is assumed that the roof

is enough durable against the extra weight of PV. The PV modules facing east and west will be installed as Figure 3.8 PV Structure for German roof . The slope of the structure for the flat roof is 10° [34]. The roof in the Korean model has its slope facing east and west. So PV modules are installed by its slope.


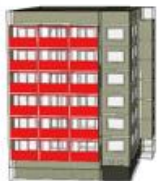



Parameters	German Model			Korean Model	
	Walls facing south	Walls facing west	Roof	Walls facing south	Roof facing east and west
					
Tilt	90° (Vertical)		10°	90° (Vertical)	16°
Orientation (from the south)	0°	90°	90° and 270°	0°	90° and 270°
Solar data	Dresden			Seoul	
PV area	1 m ²				

Table 3.12 Parameters for Opaque PV

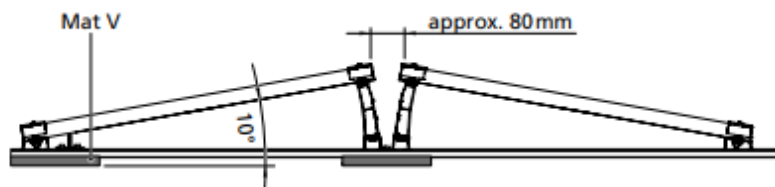


Figure 3.8 PV Structure for German roof [34]

The grid system for utilization of electrical energy and how to compare the hourly electricity are the same as Scenario 3.

Advantages and Disadvantages

Advantages

- High electricity production with the high conversion efficiency

Disadvantages

- Structure test for additional weight
- Difficulty of installation in high buildings
- Higher costs for façade PV modules caused by desired extra certifications

4 Results of Analysis

4.1 Results of Simulations

The load profiles for heating and cooling demands as well as the electrical energy from the PV modules of the German and Korean models were gained. The results of simulations for Scenario 1-3 will be presented in a similar way in order. The results of simulations for all scenarios will be analyzed in terms of heating and cooling demand, electricity for the loads, and daylighting. The coefficients of performance for an electrical driven cooling machine and a electrical driven ground source heat pump is assumed as 3 which is used for calculation of the loads. The total electricity production of Scenario 3-4 is calculated by an hour and analyzed into the in-house consumption, electricity fed into the grid, and the remaining electricity demand from the grid.

4.1.1 Results of Scenario 1

The overall electricity demand for heating and cooling is 26.3 kWh/m² for the German residential building and 14.2 kWh/m² for the Korean residential building during the period between 1st January and 31st December. These values were calculated from the annual energy demands for heating and cooling divided by 3 of energy performance coefficient for a cooling machine and a heat pump as well as the total floor area because of the comparison for each model. The electricity demands and CO₂ emissions for the whole building of each model are summarized in Table 4.1. The CO₂ emissions of the German model are 10.53 kg of CO₂ per m² and those of the Korean are 6.98 kg of CO₂ per m². The hourly electricity and energy demands for heating and cooling combined with all variations related to electricity production from PV modules are referred to Appendix.

On the other hand, the equations below show the electricity demand for heating and cooling for m² and CO₂ emissions.

- Electricity demand for heating and cooling for m² = Energy demand for heating and cooling (Table 4.3 and Table 4.4) ÷ 3 (COP) ÷ Total floor area

e.g. annual electricity demand per m² for the German model = (5335 kWh + 120700 kWh) ÷ 3 ÷ 1600.36 m² = 26.25 kWh/m²

- CO₂ emissions per m² = annual electricity consumption × CO₂ emission factor (Table 4.2) ÷ Total floor area

e.g. annual CO₂ emissions per m² for the German model = 42012 kWh × 0.401 kg of CO₂/kWh ÷ 1600.36 m² = 10.53 kg of CO₂/m²

Scenario 1	German Model	Korean Model
Electricity demand per m ² living area (kWh/m ²)	26.25	14.19
Electricity demand for cooling with compression cooling machine with annual COP of 3 (kWh/a)	1778	21339
Electricity demand for heating with ground source heat pump with annual COP of 3 (kWh/a)	40233	47829
Electricity demand for heating and cooling (kWh/a)	42012	69168
Total floor area (m ²)	1600.36	4873.62
Total CO ₂ emissions per m ² (kg of CO ₂ /m ²)	10.53	6.98
CO ₂ emissions for cooling (kg of CO ₂)	713.08	10498.59
CO ₂ emissions for heating (kg of CO ₂)	16133.54	23532.02
Total CO ₂ emissions (kg of CO ₂)	16846.62	34030.61

Table 4.1 Comparison of Electricity demand and CO₂ emission in Scenario 1

(unit: kg of CO ₂ /kWh)	Germany	Korea
CO ₂ emissions by electricity mix	0.401	0.492

Table 4.2 CO₂ emission factors for Germany and Korea [35] [36]

German Model Scenario 1 (unit: kWh/a)	Energy Demand for Cooling	Electricity demand for cooling with compression cooling machine with annual COP of 3	Energy Demand for Heating	Electricity demand for heating with ground source heat pump with annual COP of 3	Electricity demand for heating and cooling
SUM	5335	1778	120700	40233	42012
January	0.00	0.00	22916.94	7638.98	7638.98
February	0.00	0.00	19923.10	6641.03	6641.03
March	3.33	1.11	15935.00	5311.67	5312.77
April	4.72	1.57	8435.32	2811.77	2813.35
May	274.30	91.43	3189.20	1063.07	1154.50
June	740.71	246.90	486.40	162.13	409.04
July	1759.30	586.43	18.59	6.20	592.63
August	2478.05	826.02	157.66	52.55	878.57
September	62.93	20.98	1951.52	650.51	671.48
October	11.40	3.80	6817.36	2272.45	2276.25
November	0.00	0.00	18332.26	6110.75	6110.75
December	0.00	0.00	22536.48	7512.16	7512.16

Table 4.3 Result of Electricity demands for German model of Scenario 1

Table 4.3 shows the electricity demands for heating and cooling for the German model in Scenario 1 which is based on the initial state. The annual energy demands for heating and cooling are 126035 kWh and the annual electricity demands are 42012 kWh using a cooling machine a heat pump with 3 of COP. The portion of the electricity demand for heating is 96% of all and Figure 4.1 displays the electricity demands for heating and cooling by month in Scenario 1.

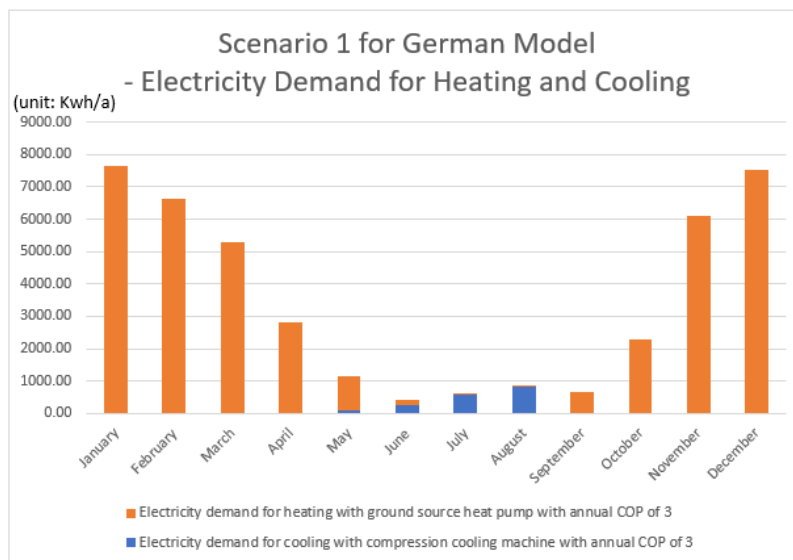


Figure 4.1 Result of Electricity demands for German model of Scenario 1

There are results of the electricity demand for heating and cooling in the Korean model of Scenario 1 in Table 4.4. The annual energy demands for heating and cooling are 207504 kWh and the annual electricity demands are 69168 kWh using a cooling machine a heat pump with 3 of COP. The portion of the electricity for heating is 69% compared to that for cooling and Figure 4.2 displays the electricity demands for heating and cooling by month.

Korean Model Scenario 1 (unit: kWh/a)	Energy Demand for Cooling	Electricity demand for cooling with compression cooling machine with annual COP of 3	Energy Demand for Heating	Electricity demand for heating with ground source heat pump with annual COP of 3	Electricity demand for heating and cooling
SUM	64016	21339	143488	47829	69168
January	0.00	0.00	41850.51	13950.17	13950.17
February	0.00	0.00	29934.14	9978.05	9978.05
March	0.00	0.00	17994.46	5998.15	5998.15
April	0.00	0.00	2605.92	868.64	868.64
May	3562.58	1187.53	0.64	0.21	1187.74
June	10116.66	3372.22	0.00	0.00	3372.22
July	18223.36	6074.45	0.00	0.00	6074.45
August	23060.35	7686.78	0.00	0.00	7686.78
September	8847.66	2949.22	0.00	0.00	2949.22
October	205.21	68.40	572.54	190.85	259.25
November	0.00	0.00	16771.69	5590.56	5590.56
December	0.00	0.00	33758.02	11252.67	11252.67

Table 4.4 Result of Electricity demands for Korean model of Scenario 1

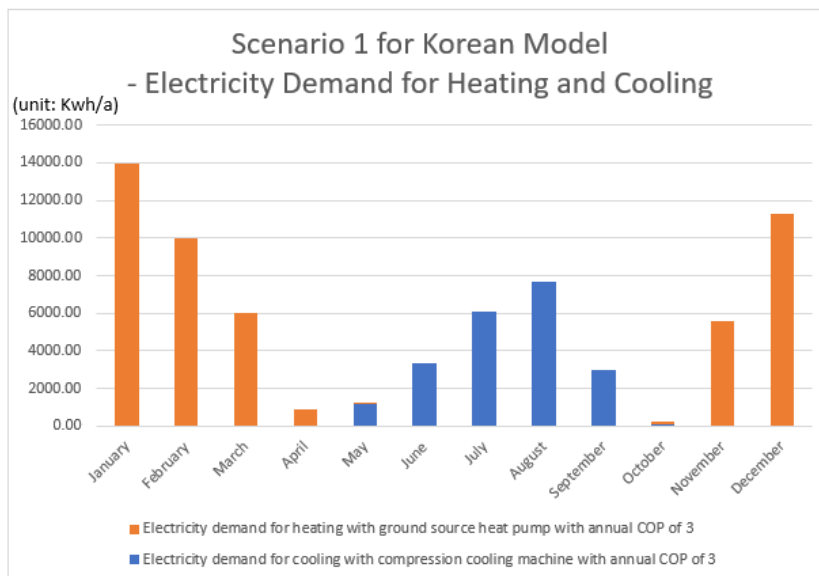


Figure 4.2 Result of Electricity demands for Korean model of Scenario 1

4.1.2 Results of Scenario 2

The annual electricity demand for heating and cooling for m² is 11.76 kWh/m² for the German residential building and 11.15 kWh/m² for the Korean residential building in Scenario 2 renovated state with enhanced insulations and windows. The CO₂ emissions in the German model are 4.72 kg of CO₂ and those in the Korean are 5.49 kg of CO₂. Total CO₂ emissions of the German model are 7546 kg of CO₂ and those of the Korean model are 26732 kg of CO₂.

Scenario 2	German Model	Korean Model
Electricity demand per m ² living area (kWh/m ²)	11.76	11.15
Electricity demand for cooling with compression cooling machine with annual COP of 3 (kWh/a)	2211	21736
Electricity demand for heating with ground source heat pump with annual COP of 3 (kWh/a)	16607	32598
Electricity demand for heating and cooling (kWh/a)	18817	54334
Total floor area (m ²)	1600.36	4873.62
Total CO ₂ emissions per m ² (kg of CO ₂ /m ²)	4.72	5.49
CO ₂ emissions for cooling (kg of CO ₂)	886.49	10693.87
CO ₂ emissions for heating (kg of CO ₂)	6659.24	16038.44
Total CO ₂ emissions (kg of CO ₂)	7545.73	26732.31

Table 4.5 Comparison of Electricity demands and CO₂ emission of Scenario 2

Table 4.6 indicates the electricity demands for heating and cooling for the German model in Scenario 2 renovated state with enhanced insulations and windows. The annual energy demands for heating and cooling are 56452 kWh and the annual electricity demands are 18817 kWh using a cooling machine a heat pump with 3 of COP. The portion of the electricity demand for heating is 88% of all and Figure 4.3 displays the electricity demands for heating and cooling by month in Scenario 2.

German Model Scenario 2 (unit: kWh/a)	Energy Demand for Cooling	Electricity demand for cooling with compression cooling machine with annual COP of 3	Energy Demand for Heating	Electricity demand for heating with ground source heat pump with annual COP of 3	Electricity demand for heating and cooling
SUM	6632	2211	49820	16607	18817
January	0.00	0.00	10390.71	3463.57	3463.57
February	0.00	0.00	9007.72	3002.57	3002.57
March	0.05	0.02	6744.31	2248.10	2248.12
April	0.01	0.00	2837.73	945.91	945.91
May	393.06	131.02	1020.67	340.22	471.24
June	1151.27	383.76	45.92	15.31	399.06
July	2293.00	764.33	0.00	0.00	764.33
August	2522.54	840.85	0.00	0.00	840.85
September	219.88	73.29	68.41	22.80	96.10
October	52.26	17.42	1585.99	528.66	546.09
November	0.00	0.00	7923.85	2641.28	2641.28
December	0.00	0.00	10194.47	3398.16	3398.16

Table 4.6 Result of Electricity demands for German model of Scenario 2

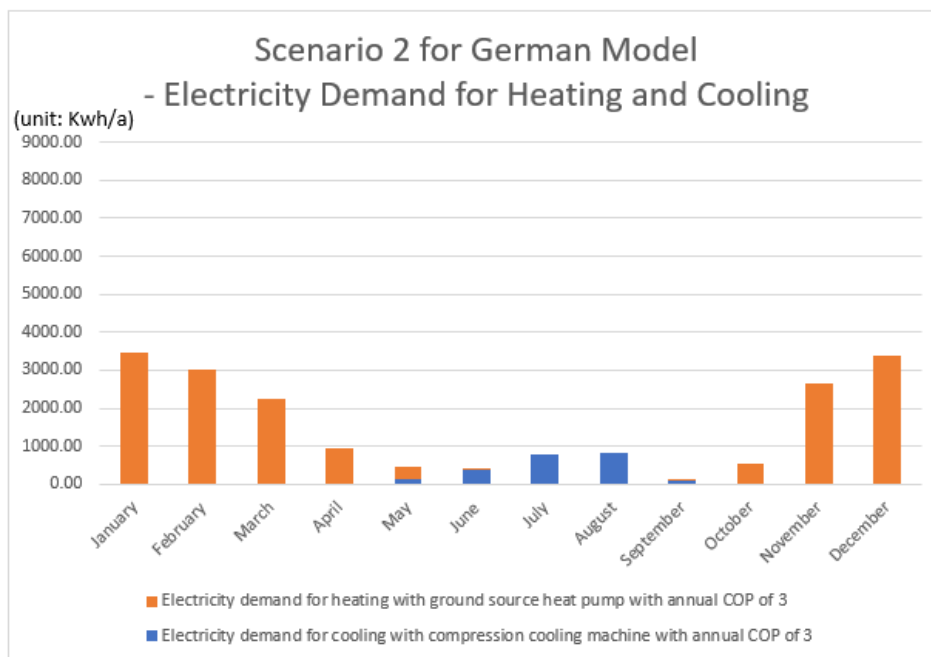


Figure 4.3 Result of Electricity demands for German model of Scenario 2

There are results of the electricity demands for heating and cooling in the Korean model of Scenario 2 in Table 4.7. The annual energy demands for heating and cooling are 163002 kWh and the annual electricity demands are 54334 kWh using a cooling machine a heat pump with 3 of COP. The portion of the electricity for heating is 60% of all and Figure 4.4. Figure 4.2 displays the electricity demands for heating and cooling by month.

Korean Model Scenario 2 (unit: kWh/a)	Energy Demand for Cooling	Electricity demand for cooling with compression cooling machine with annual COP of 3	Energy Demand for Heating	Electricity demand for heating with ground source heat pump with annual COP of 3	Electricity demand for heating and cooling
SUM	65207	21736	97795	32598	54334
January	0.00	0.00	30233.87	10077.96	10077.96
February	0.00	0.00	21112.76	7037.59	7037.59
March	0.00	0.00	11386.42	3795.47	3795.47
April	28.77	9.59	788.76	262.92	272.51
May	5132.67	1710.89	0.00	0.00	1710.89
June	10663.12	3554.37	0.00	0.00	3554.37
July	17720.12	5906.71	0.00	0.00	5906.71
August	21576.14	7192.05	0.00	0.00	7192.05
September	9359.84	3119.95	0.00	0.00	3119.95
October	725.88	241.96	18.87	6.29	248.25
November	0.00	0.00	10284.22	3428.07	3428.07
December	0.00	0.00	23970.47	7990.16	7990.16

Table 4.7 Result of Electricity demands for Korean model of Scenario 2

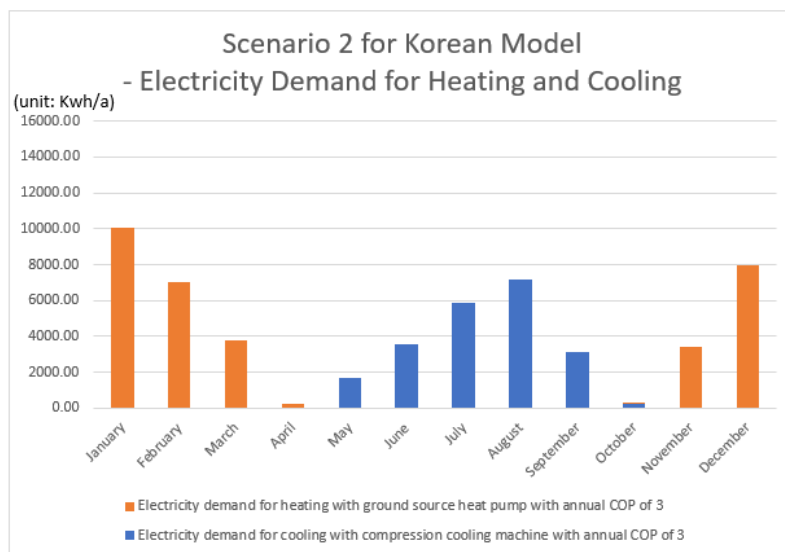


Figure 4.4 Result of Electricity demands for Korean model of Scenario 2

4.1.3 Results of Scenario 3

There are 2 kinds of simulations for Scenario 3 based on both Scenario 1 and Scenario 2. Scenario 3 based on Scenario 1 was evaluated using the initial state of the models with semi-transparent PV modules. And Scenario 3 based on Scenario 2 was evaluated using the renovated state of the models with semi-transparent PV modules. So the total simulations are 4 for all cases in Scenario 3.

Firstly, the result of Scenario 3 based on Scenario 1 with semi-transparent PV modules in Table 4.8. The annual energy demand for heating and cooling per m² is 26.81 kWh/m² for the German residential building and 14.19 kWh/m² for the Korean residential building. The CO₂ emissions per m² of the German model are 10.75 kg of CO₂ and those of the Korean model are 6.98 kg of CO₂. Total CO₂ emissions of the German model are 17206 kg of CO₂ and those of the Korean model are 34022 kg of CO₂.

Scenario 3 based on Scenario 1 with semi-transparent PV modules	German Model	Korean Model
Electricity demand per m² living area (kWh/m²)	26.81	14.19
Electricity demand for cooling with compression cooling machine with annual COP of 3 (kWh/a)	1339	16654
Electricity demand for heating with ground source heat pump with annual COP of 3 (kWh/a)	41568	52496
Electricity demand for heating and cooling (kWh/a)	42908	69150
Total floor area (m²)	1600.36	4873.62
Total CO₂ emissions per m² (kg of CO₂/m²)	10.75	6.98
CO₂ emissions for cooling (kg of CO₂)	537.12	8193.73
CO₂ emissions for heating (kg of CO₂)	16668.83	25828.26
Total CO₂ emissions (kg of CO₂)	17205.95	34021.98

Table 4.8 Comparison of Electricity demand and CO₂ emission of Scenario 3 based on Scenario 2

The results of the heating and cooling demands for electricity in the German model in Scenario 3 are provided in Table 4.9. The annual energy needs for heating and cooling are 128722 kWh, and the annual power requirements are 42908 kWh using a cooling machine and a heating pump with 3 of COP. The percentage of electricity for heating is 97% and Figure 4.5 indicates monthly energy needs for heating and cooling.

German Model Scenario 3 based on Scenario 1 with semi-transparent PV modules (unit: kWh/a)	Energy Demand for Cooling	Electricity demand for cooling with compression cooling machine with annual COP of 3	Energy Demand for Heating	Electricity demand for heating with ground source heat pump with annual COP of 3	Electricity demand for heating and cooling
SUM	4018	1339	124704	41568	42908
January	0.00	0.00	23219.48	7739.83	7739.83
February	0.00	0.00	20374.76	6791.59	6791.59
March	0.14	0.05	16482.21	5494.07	5494.12
April	2.15	0.72	9031.59	3010.53	3011.25
May	168.92	56.31	3455.48	1151.83	1208.13
June	534.17	178.06	598.95	199.65	377.70
July	1316.65	438.88	23.61	7.87	446.75
August	1979.81	659.94	186.73	62.24	722.18
September	16.56	5.52	2265.18	755.06	760.58
October	-0.02	-0.01	7474.37	2491.46	2491.45
November	0.00	0.00	18743.09	6247.70	6247.70
December	0.00	0.00	22849.02	7616.34	7616.34

Table 4.9 Result of Electricity demand for German model of Scenario 3 based on Scenario 1

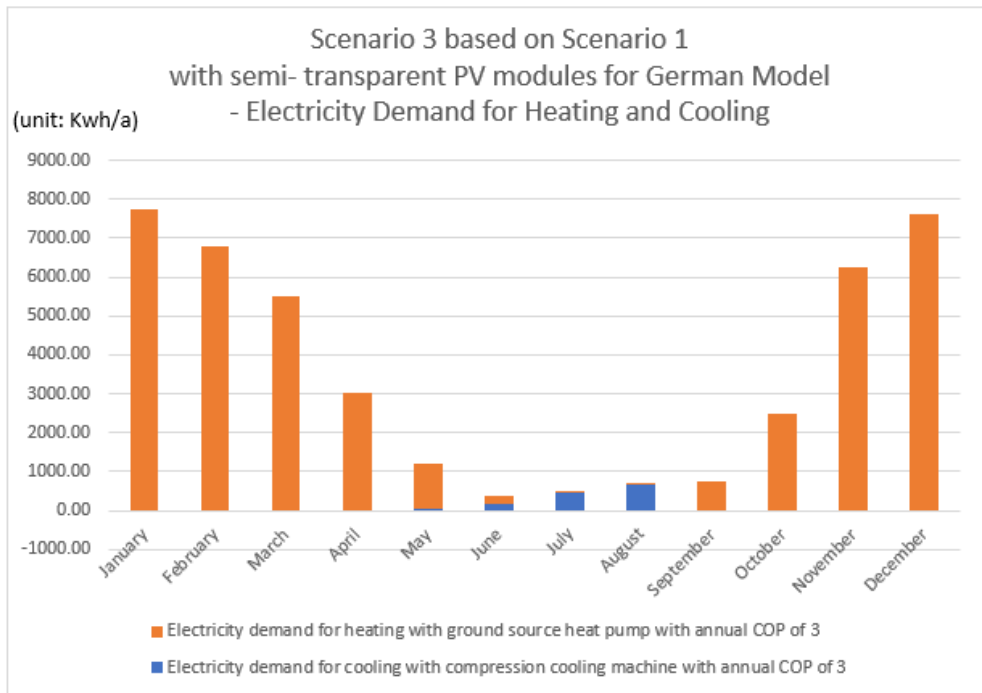


Figure 4.5 Result of Electricity demand for German model of Scenario 3 based on Scenario 1

The annual electricity demands for heating and cooling for the Korean model in Scenario 3 are described in Table 4.10. The annual energy demands for heating and cooling are 207451 kWh and the annual electricity demands are 69150 kWh using a cooling machine a heat pump with 3 of COP. The share of heating power is 76 percent of all and Figure 4.6 presents monthly energy needs for heating and cooling.

Korean Model Scenario 3 based on Scenario 1 with semi-transparent PV modules (unit: kWh/a)	Energy Demand for Cooling	Electricity demand for cooling with compression cooling machine with annual COP of 3	Energy Demand for Heating	Electricity demand for heating with ground source heat pump with annual COP of 3	Electricity demand for heating and cooling
SUM	49962	16654	157489	52496	69150
January	0.00	0.00	43579.95	14526.65	14526.65
February	0.00	0.00	31978.17	10659.39	10659.39
March	0.00	0.00	21264.67	7088.22	7088.22
April	0.00	0.00	4782.00	1594.00	1594.00
May	950.64	316.88	13.49	4.50	321.38
June	6941.96	2313.99	0.00	0.00	2313.99
July	15390.55	5130.18	0.00	0.00	5130.18
August	20085.03	6695.01	0.00	0.00	6695.01
September	6583.62	2194.54	0.00	0.00	2194.54
October	9.95	3.32	1587.71	529.24	532.55
November	0.00	0.00	18810.16	6270.05	6270.05
December	0.00	0.00	35473.24	11824.41	11824.41

Table 4.10 Result of Electricity demand for Korean model of Scenario 3 based on Scenario 1

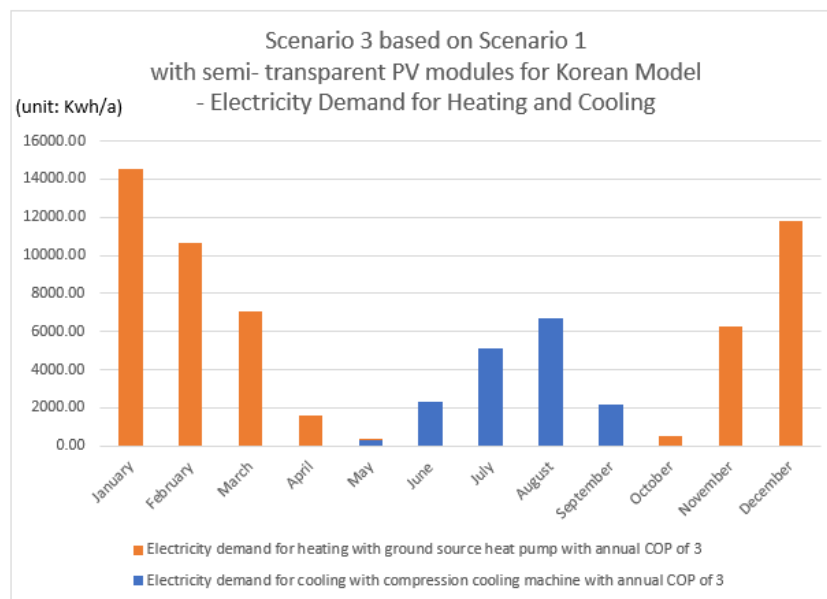


Figure 4.6 Result of Electricity demand for Korean model of Scenario 3 based on Scenario 1

Next, the result of Scenario 3 based on Scenario 2 which is improved with additional insulations with semi-transparent PV modules in Table 4.11. The energy demand per m² is 11.92 kWh/m² in the German building while 10.96 kWh/m² in the Korean building. The CO₂ emissions per m² in the German model are 4.78 kg of CO₂ while those in the Korean model are 5.39 kg of CO₂. Total CO₂ emissions in the German model are 7648 kg of CO₂ and those in the Korean model are 26280 kg of CO₂.

Scenario 3 based on Scenario 2 with semi- transparent PV modules	German Model	Korean Model
Electricity demand per m² living area (kWh/m²)	11.92	10.96
Electricity demand for cooling with compression cooling machine with annual COP of 3 (kWh/a)	1757	17021
Electricity demand for heating with ground source heat pump with annual COP of 3 (kWh/a)	17315	36393
Electricity demand for heating and cooling (kWh/a)	19072	53414
Total floor area (m²)	1600.36	4873.62
Total CO₂ emissions per m² (kg of CO₂/m²)	4.78	5.39
CO₂ emissions for cooling (kg of CO₂)	704.46	8374.33
CO₂ emissions for heating (kg of CO₂)	6943.38	17905.54
Total CO₂ emissions (kg of CO₂)	7647.85	26279.86

Table 4.11 Comparison of Electricity demand and CO₂ emission of Scenario 3 based on Scenario 2

Table 4.12 indicates the electricity demands for heating and cooling of the German building in Scenario 3 based on Scenario 2 improved by insulations from Scenario 1. The annual energy demands for heating and cooling are 57216 kWh and the annual electricity needs are 19072 kWh using cooling and heating machines with 3 of COP. The percentage of heating electricity is 91% and the monthly electricity demands for heating and cooling are shown in Figure 4.7.

German Model Scenario 3 based on Scenario 2 with semi-transparent PV modules (unit: kWh/a)	Energy Demand for Cooling	Electricity demand for cooling with compression cooling machine with annual COP of 3	Energy Demand for Heating	Electricity demand for heating with ground source heat pump with annual COP of 3	Electricity demand for heating and cooling
SUM	5270	1757	51946	17315	19072
January	0.00	0.00	10585.16	3528.39	3528.39
February	0.00	0.00	9293.23	3097.74	3097.74
March	0.00	0.00	7090.20	2363.40	2363.40
April	0.00	0.00	3206.25	1068.75	1068.75
May	267.32	89.11	1138.22	379.41	468.51
June	888.15	296.05	54.96	18.32	314.37
July	1913.83	637.94	0.00	0.00	637.94
August	2118.17	706.06	0.00	0.00	706.06
September	82.13	27.38	83.71	27.90	55.28
October	0.69	0.23	1900.74	633.58	633.81
November	0.00	0.00	8206.59	2735.53	2735.53
December	0.00	0.00	10386.45	3462.15	3462.15

Table 4.12 Result of Electricity demand for German model of Scenario 3 based on Scenario 2

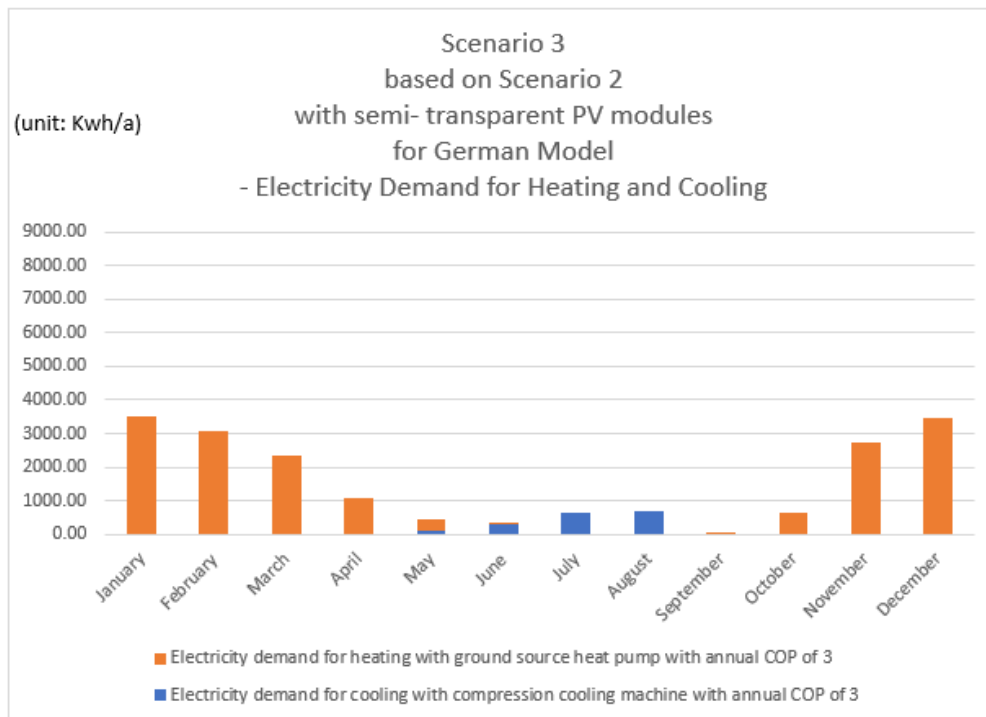


Figure 4.7 Result of Electricity demand for German model of Scenario 3 based on Scenario 2

Table 4.13 shows the electricity demands for heating and cooling of the Korean building in Scenario 3 based on Scenario 2 enhanced by insulations from Scenario 1. The energy demands for heating and cooling per 1 year are 160243 kWh and the electricity demands are 53414 kWh using cooling and heating machines with 3 of COP for 1 year. The monthly electricity demands for heating and cooling are displayed in Figure 4.8 and the electricity percentage of heating is 68% compared to that of cooling.

Korean Model Scenario 3 based on Scenario 2 with semi-transparent PV modules (unit: kWh/a)	Energy Demand for Cooling	Electricity demand for cooling with compression cooling machine with annual COP of 3	Energy Demand for Heating	Electricity demand for heating with ground source heat pump with annual COP of 3	Electricity demand for heating and cooling
SUM	51063	17021	109180	36393	53414
January	0.00	0.00	31765.58	10588.53	10588.53
February	0.00	0.00	22955.83	7651.94	7651.94
March	0.00	0.00	14269.74	4756.58	4756.58
April	0.00	0.00	2103.53	701.18	701.18
May	1834.32	611.44	0.00	0.00	611.44
June	7802.25	2600.75	0.00	0.00	2600.75
July	15152.02	5050.67	0.00	0.00	5050.67
August	18891.97	6297.32	0.00	0.00	6297.32
September	7158.39	2386.13	0.00	0.00	2386.13
October	224.03	74.68	209.94	69.98	144.66
November	0.00	0.00	12383.93	4127.98	4127.98
December	0.00	0.00	25491.54	8497.18	8497.18

Table 4.13 Result of Electricity demand for Korean model of Scenario 3 based on Scenario 2

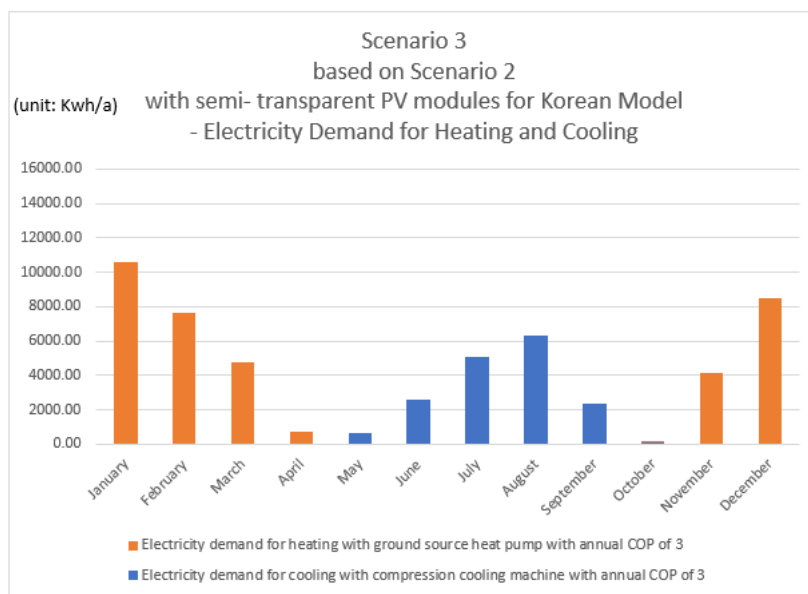


Figure 4.8 Result of Electricity demand for Korean model of Scenario 3 based on Scenario 2

Results of Electricity production from semi-transparent PV modules

Figure 4.9 and Figure 4.10 indicate the electricity generated from semi-transparent PV modules for the German and Korean models. The annual electricity production for the German model is 1452 kWh while that for the Korean model is 27037 kWh. The annual electricity per m^2 for the German model is 51.2 kWh/ m^2 and that of the Korean model is 50.6 kWh/ m^2 .

The difference of 0.7 kWh/ m^2 is due to the difference in solar production regarding the directions where the buildings are facing. The direction of the German model is in the south where solar modules are installed, and in the Korean model, solar modules are installed in the east and west.

The monthly electricity production is various for the 2 models. The monthly electricity generated in the German model is 4 kWh/ m^2 or more from March to October except for winter. But in the Korean model, its value is the highest between March and June. Because Korea has a rainy season in Summer.

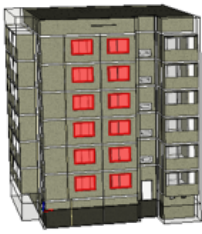
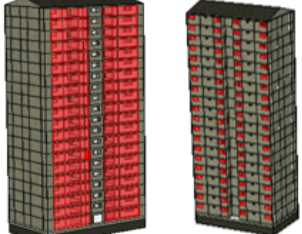
Scenario 3	German Model	Korean Model
	German_South Facade Semi-transparent PV_6%	Korean_East & West Facade Semi-transparent PV_6%
		
Total annual generated electricity (kWh/a)	1452.72	27037.66
PV area for the building (m^2)	28.35	534.60
SUM of electricity production (kWh/ m^2)	51.24	50.57
January	2.04	2.61
February	3.25	3.09
March	4.45	4.91
April	4.99	5.81
May	5.76	6.48
June	4.61	4.99
July	5.46	4.42
August	5.92	4.66
September	4.89	4.12
October	5.29	4.12
November	2.44	2.93
December	2.17	2.45

Figure 4.9 Annual Electricity Production from Semi-transparent PV modules

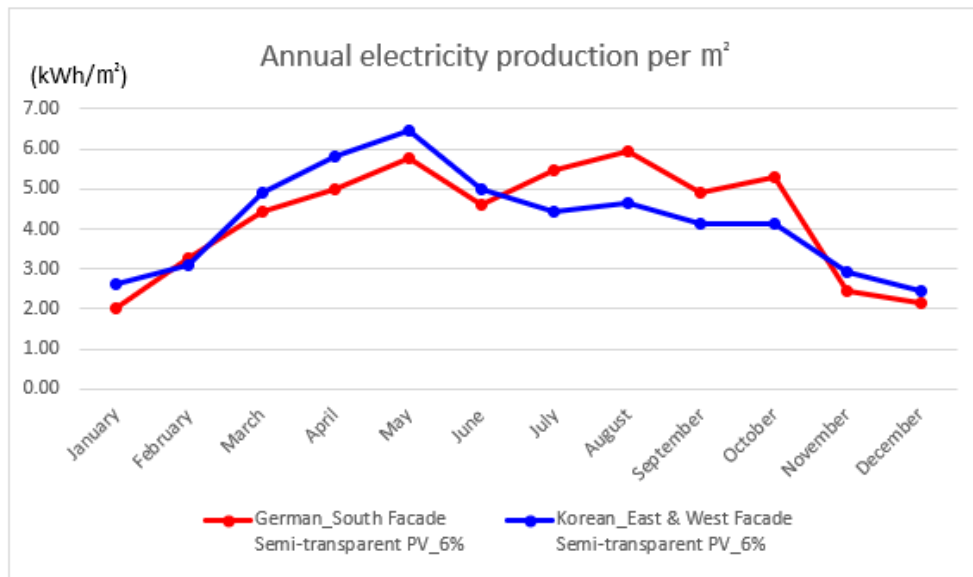


Figure 4.10 Annual Electricity Production per m² from Semi-transparent PV modules

Results of Indoor Daylight

Figure 4.11 displays how different the indoor daylight is in the rooms affected by the windows installed with semi-transparent PV modules on the date when sunlight is the shortest of 1 year. The simulation time is 9 a.m. Firstly, the 2 rooms of Scenario 1 in the German model have average illuminance of 235 Lux or more. Its values are more than half as low after retrofitting with semi-transparent solar modules. Also, after the renovated state in Scenario 2, the initial double windows were changed to the triple windows so the sunlight values inside the rooms are lower as much as the effect of g value of the new windows. The values after its renovating and retrofitting are the lowest of all cases as expected. While the values in the German model are lower according to the 4 cases, the values in the Korean model are similar between Scenario 1 and Scenario 2 as well as the values after semi-transparent PV modules installing. Because the windows in both the initial and renovated states are the same as double glazing. So the g value is the same for both Scenario 1 and Scenario 2. The zones colored in the Korean model are affected by the windows installed with solar modules since they were connected through windows or glazing doors. The indoor daylight in the balconies are of course enough high but in other zones where occupants inhabit mainly, the values are low as 100 Lux or less.

The values of the monthly indoor daylight for selected zones in different Scenarios are shown in Figure 4.12 and Figure 4.13. The zones are chosen for comparisons of the daylight inside the main living area. The first case of Scenario 1 in the German model is the initial state with double glazing and the other one of Scenario 3 based on Scenario is the renovated state, which means the early and the last stages relate to the energy performance. The daylight of the primary stage is 640.3 Lux while that of the last stage is 266.9 Lux in the German model. So the daylight is reduced as 58 % but the values are much brighter for indoor activity compared to that general lighting is between 50 – 100 Lux in residences [37]. And in the Korean model, 82.39 Lux is for the early case and 49.2 Lux is for the last case. Both values

are around between the ranges for residences. Therefore, the indoor daylight for all cases is enough for indoor activities.

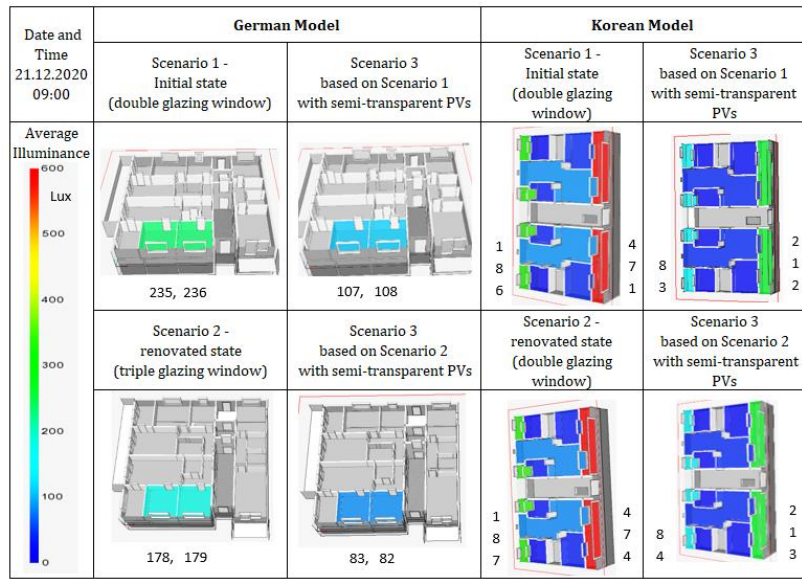


Figure 4.11 Floor plans with Average Illuminance of each Scenario for the German and Korean Models on the 21st of December

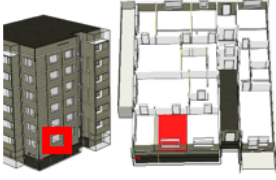
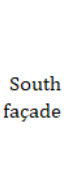

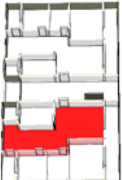
Monthly Average Daylight at desktop (unit: Lux)	German Model		Korean Model	
	Scenario 1 - Initial state - L01_A01_Sleeping room (double glazing window)	Scenario 3 - Renovated state based on Scenario 2 L01_A01_Sleeping room (triple glazing window)	Scenario 1 - Initial state - L00_A01_Livingroom (double glazing window)	Scenario 3 - Renovated state based on Scenario 2 L00_A01_Livingroom (double glazing window)
				
Reduction ratio (%)	58%		40%	
mean	640.3	266.9	82.39	49.2
January	349.2	144.9	47.22	28.58
February	737.3	305.2	61.9	37.39
March	870.4	360.7	88.88	53.2
April	710	297	129.8	75.36
May	541.3	228.1	132.8	77.78
June	510.1	214.9	92.45	56.05
July	532.2	224.2	82.71	50.27
August	595.8	250.7	96.26	57.18
September	881.5	366.1	83.72	50.01
October	1169.8	484.2	70.25	42.71
November	456.2	189.1	54.58	32.99
December	338.3	141	47.17	28.29

Figure 4.12 Comparison of Monthly Average Daylight for the rooms in Scenario 1 and Scenario 3 based on Scenario 2

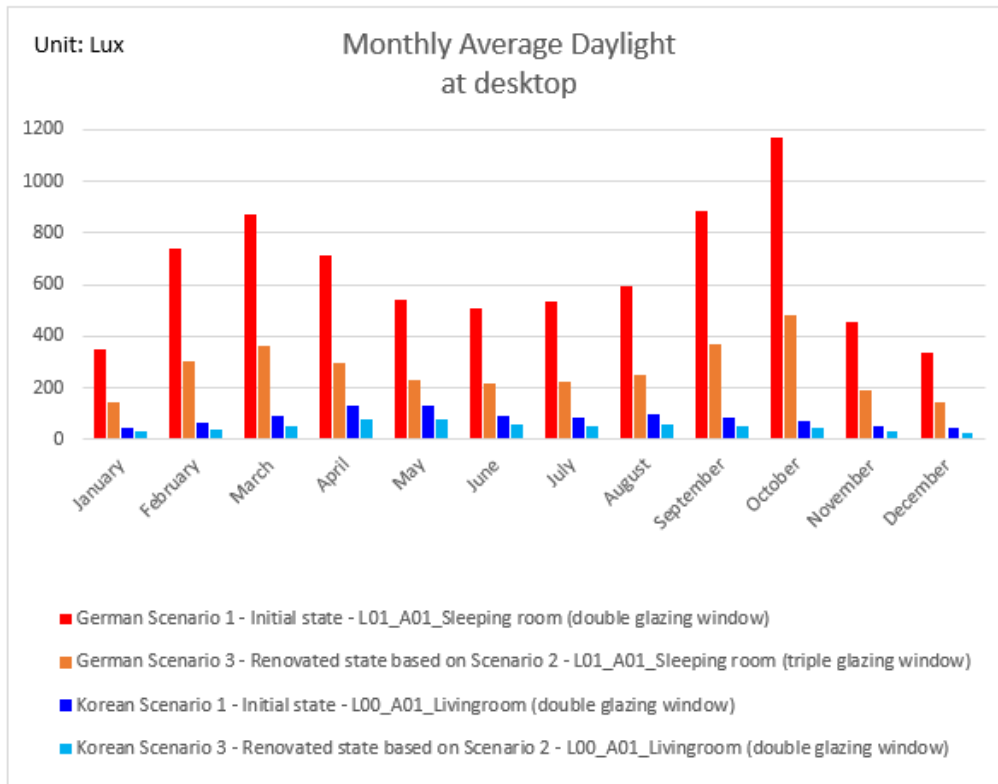


Figure 4.13 Comparison of Monthly Average Daylight for the rooms in Scenario 1 and Scenario 3 based on Scenario 2

4.1.4 Results of Scenario 4

As mentioned in chapter 3.3.4, energy demands for heating and cooling for the models are not affected by opaque Photovoltaics since PV modules are installed on the opaque walls and roofs unlike Scenario 3 with retrofitted windows installed with semi-transparent solar modules. Hence the results of energy demands for heating and cooling in Scenario 4 are the same as the results of Scenario 1 and 2 and the only difference is whether or not electricity production from opaque PVs is present.

Results of Electricity production from opaque PV modules

There are 4 cases for the annual electricity generated from opaque PVs for each model in Figure 4.14 and Figure 4.15. The annual generated power is 18856.61 kWh from the south and west walls and 30103.56 kWh from the roof with PVs facing east and west with the slope of 10° in the German building while 117526.53 kWh from the south walls and 53735.76 kWh from the roof facing east and west with PVs with the slope of 16° in the Korean model. The electricity per m² is the highest of 231.64 kWh/m² in the Korean roof facing east and west and the lowest is in the German walls facing south and west. The differences are from the direction and slope of all cases.



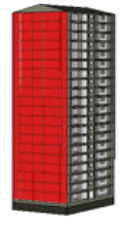
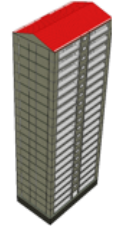
Scenario 4	German Model			Korean Model		
	German_South & West Facade Opaque PV_20%	German_Flat Roof East & West Opaque PV_20%	SUM	Korean_South Facade Opaque PV_20%	Korean_East & West Slope Roof Opaque PV_20%	SUM
						
Total annual generated electricity (kWh/a)	18856.61	30103.53	48960.13	117526.53	53735.76	171262.29
PV area for the building (m²)	128.39	173.68	302.07	575.64	231.98	807.62
SUM of electricity production (kWh/m²)	154.32	173.33	327.64	204.22	231.64	435.86
January	4.91	3.28	8.19	17.42	10.18	27.60
February	8.26	6.04	14.30	17.55	12.95	30.50
March	12.62	12.33	24.95	20.10	21.138	41.24
April	16.20	18.35	34.54	18.90	28.33	47.23
May	19.94	27.68	47.62	15.88	31.227	47.11
June	16.43	23.61	40.04	12.94	25.836	38.78
July	19.20	27.50	46.70	12.23	22.125	34.36
August	19.18	23.91	43.09	14.29	22.465	36.76
September	13.71	14.35	28.06	16.11	18.964	35.07
October	13.13	9.72	22.85	21.70	17.282	38.98
November	5.83	3.91	9.75	19.54	11.621	31.16
December	4.92	2.66	7.58	17.56	9.519	27.08

Figure 4.14 Annual Electricity Production from Opaque PV modules

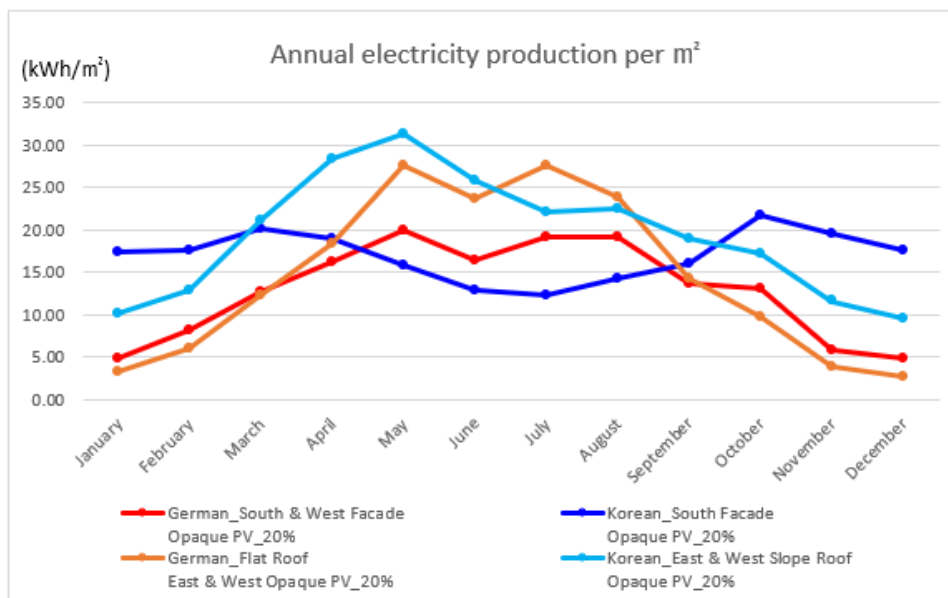


Figure 4.15 Annual Electricity Production per 1 m² from Walls and Roof with Opaque PV modules

Results of Variations based on Scenario 1 with Electricity production

There are 2 kinds of results of total in-house consumption of electricity production, electricity fed into the grid, and remaining electricity for demands with variations based on Scenario 1 which is the initial state and Scenario 2 of the renovated state (Figure 4.16 and Figure 4.17). The reason why results divided into 2 results based on Scenario 1 and 2 is electricity demands for heating and cooling are different. The amount of electricity generated from each case of PVs is divided into electricity used at home, electricity fed into the grid, and remaining electricity for demands by hour. So the power amount used at home is different from one another since hourly electricity generated is not the same.

The first types are results with semi-transparent and opaque PV modules based on Scenario 1. Figure 4.16 shows 4 kinds of cases in terms of electricity production by the grid-connected system for each model. The highest value in the ratio of in-house consumption of electricity production is 79% of electricity generated for the German model with semi-transparent PV modules since the total power generated is very low so its 79% is used at home and 97% of electricity demands for heating and cooling. The lowest percentage in the ratio of in-house consumption of electricity production is 15% of the total power amount in the Korean model with all variations, which means electricity production is very high of 198300 kWh. And additional electricity ratio for heating and cooling is 56% which is the lowest of all cases.





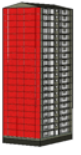

Scenario 1 with additional variations	German Model			SUM	Korean Model			SUM
	Scenario 3	Scenario 4			Scenario 3	Scenario 4		
	German_South Facade Semi-transparent PV_6%	German_South & West Facade Opaque PV_20%	German_Flat Roof East & West Opaque PV_20%		Korean_East & West Facade Semi-transparent PV_6%	Korean_South Facade Opaque PV_20%	Korean_East & West Slope Roof Opaque PV_20%	
								
PV area (m ²)	28.35	128.39	173.68	330.42	534.60	575.64	231.98	1342.22
Electricity generation from PV (kWh/a)	1452.72	18856.61	30103.53	50412.85	27037.66	117526.53	53735.76	198299.95
Electricity generation from PV per m ² PV-area (kWh/m ² a)	51.24	146.88	173.33	152.57	50.58	204.17	231.64	147.74
Electricity demand for cooling (kWh/a)	1339.46	1778.24	1778.24	1339.46	16653.91	21338.61	21338.61	16653.91
Electricity demand for heating (kWh/a)	41568.16	40233.28	40233.28	41568.16	52496.46	47829.30	47829.30	52496.46
Electricity demand for heating and cooling (kWh/a)	42907.61	42011.52	42011.52	42907.61	69150.38	69167.91	69167.91	69150.38
Electricity demand per m ² living area (kWh/m ²)	26.81	26.25	26.25	26.81	14.19	14.19	14.19	14.19
In-house consumption of PV (kWh/a)	1150.48	7150.44	7727.17	10522.22	14898.08	28096.10	20950.85	30502.82
Ratio of In-house consumption of PV (%)	79%	38%	26%	21%	55%	24%	39%	15%
Electricity demand per m ² living area after in-house consumption of PV (kWh/m ²)	26.09	21.78	21.42	20.24	11.13	8.43	9.89	7.93
Electricity from PV system fed into the grid (kWh/a)	302.24	11706.17	22376.36	39890.64	12139.58	89430.43	32784.91	167797.13
Remaining electricity demand from the grid for heating and cooling (kWh/a)	41757.13	34861.08	34284.35	32385.40	54252.30	41071.81	48217.06	38647.55
Ratio of Remaining electricity demand from the grid for heating and cooling (%)	97%	83%	82%	75%	78%	59%	70%	56%

Figure 4.16 Variations based on Scenario 1 related to Electricity production

The next types are results with semi-transparent and opaque PV modules based on Scenario 2. 4 kinds of cases in terms with electricity production by the grid-connected system for each model are presented in Figure 4.17. The very high ratio in in-house consumption of electricity production is 73% of electricity generated for the German model with semi-transparent PV modules and 94% of remaining electricity demands for heating and cooling. The very low ratio in in-house consumption of electricity generated is 13% of total power in both the German and Korean models with all variations.


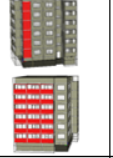

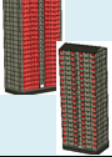
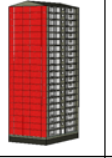
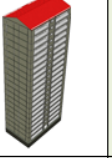
Scenario 2 with additional variations	German Model			SUM	Korean Model			SUM
	Scenario 3	Scenario 4			Scenario 3	Scenario 4		
	German_South Facade Semi-transparent PV_6%	German_South & West Facade Opaque PV_20%	German_Flat Roof East & West Opaque PV_20%		Korean_East & West Facade Semi-transparent PV_6%	Korean_South Facade Opaque PV_20%	Korean_East & West Slope Roof Opaque PV_20%	
								
PV area (m ²)	28.35	128.39	173.68	330.42	534.60	575.64	231.98	1342.22
Electricity generation from PV (kWh/a)	1452.72	18856.61	30103.53	50412.85	27037.66	117526.53	53735.76	198299.95
Electricity generation from PV per m ² PV-area (kWh/m ² a)	51.24	146.88	173.33	152.57	50.58	204.17	231.64	147.74
Electricity demand for cooling (kWh/a)	1756.76	2210.69	2210.69	1756.76	17020.99	21735.51	21735.51	17020.99
Electricity demand for heating (kWh/a)	17315.17	16606.59	16606.59	17315.17	36393.36	32598.46	32598.46	36393.36
Electricity demand for heating and cooling (kWh/a)	19071.93	18817.28	18817.28	19071.93	53414.36	54333.96	54333.96	53414.36
Electricity demand per m ² living area (kWh/m ²)	11.92	11.76	11.76	11.92	10.96	11.15	11.15	10.96
In-house consumption of PV (kWh/a)	1063.88	4904.27	5270.48	6305.89	14112.93	23671.39	19102.81	24941.25
Ratio of In-house consumption of PV (%)	73%	26%	18%	13%	52%	20%	36%	13%
Electricity demand per m ² living area after in-house consumption of PV (kWh/m ²)	11.25	8.69	8.46	7.98	8.06	6.29	7.23	5.84
Electricity from PV system fed into the grid (kWh/a)	388.84	13952.33	24833.05	44106.96	12924.73	93855.14	34632.95	173358.70
Remaining electricity demand from the grid for heating and cooling (kWh/a)	18008.06	13913.01	13546.81	12766.04	39301.43	30662.57	35231.16	28473.10
Ratio of Remaining electricity demand from the grid for heating and cooling (%)	94%	74%	72%	67%	74%	56%	65%	53%

Figure 4.17 Variations based on Scenario 2 related to Electricity production

4.2 Analysis

The analysis will compare the results of electricity demands for Scenario 1–4 with all variations as well as electricity calculated from internal loads and fed into the grid.

4.2.1 Electricity demand of Scenario 1 and 2

The annual electricity demand summary between Scenario 1 and 2 for both models is displayed in Figure 4.14 and Figure 4.15. The annual electricity demand per m² is reduced by 14.5 kWh for the German model applied improved insulation layers and triple glazing windows. The result gives a 55% savings of the annual electricity requirement. Hence the CO₂ emissions are decreased as much as 55%. In the Korean model, the value is reduced by 3.0 kWh by applying additional insulations and double-glazing windows with better energy performance. This saves energy and CO₂ emissions of 21%.

	German Model			Korean Model		
	Scenario 1 - Initial state	Scenario 2 - Renovated state	Savings (%)	Scenario 1 - Initial state	Scenario 2 - Renovated state	Savings (%)
Electricity demand per m ² living area (kWh/yr/m ²)	26.25	11.76	55%	14.19	11.15	21%
Electricity demand for cooling per m ² living area (kWh/yr/m ²)	1.11	1.38	-24%	4.38	4.46	-2%
Electricity demand for heating per m ² living area (kWh/yr/m ²)	25.14	10.38	59%	9.81	6.69	32%
Total CO ₂ emissions per m ² (kg of CO ₂ /kWh/m ²)	10.53	4.72	55%	6.98	5.49	21%

Table 4.14 Comparison of Electricity demands for heating and cooling per m² in Scenario 1 and Scenario 2

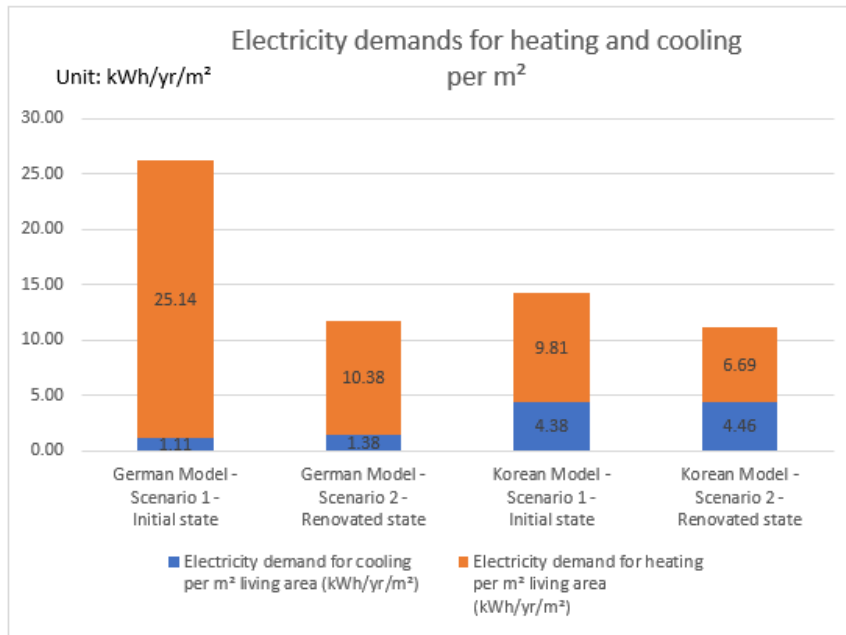


Figure 4.18 Comparison of Electricity demands for heating and cooling per m² in Scenario 1 and Scenario 2

4.2.2 Variations based on Scenario 1 with no Electricity production

Table 4.15 and Figure 4.19 indicate the electricity demands in variations based on Scenario 1 with no electricity production. Before comparisons with the electricity production, there should be simple comparisons of electricity demands for how many demands are required for each variation in Scenario 1. In the variation applied semi-transparent PV modules, the annual electricity demands for heating and cooling increased by 0.56 kWh/m² compared to the initial state. The requirement for cooling decreased by 0.27 kWh/m² but 0.83 kWh for heating increased. This increases the electricity demand by 2.13%. In the Korean model, the variation with semi-transparent PV modules has a slightly low value by 14.189 kWh/m². The demands are reduced by 0.003 kWh/m².

based on Scenario 1 applied with no electricity production	German Model					Korean Model				
	Scenario 1 - Initial state	Scenario 3 - South Façade Semi-transparent PV_6%	Scenario 4 - South & West Façade Opaque PV_20%	Scenario 4 - Flat Roof East & West Opaque PV_20%	Scenario 1 - Initial state with all variations	Scenario 1 - Initial state	Scenario 3 - East & West Façade Semi-transparent PV_6%	Scenario 4 - South Façade Opaque PV_20%	Scenario 4 - East & West Slope Roof Opaque PV_20%	Scenario 1 - Initial state with all variations
Electricity demand per m ² living area (kWh/yr/m ²)	26.25	26.81	26.25	26.25	26.81	14.192	14.189	14.192	14.192	14.189
Electricity demand for cooling (kWh/yr/m ²)	1.11	0.84	1.11	1.11	0.84	4.38	3.42	4.38	4.38	3.42
Electricity demand for heating (kWh/yr/m ²)	25.14	25.97	25.14	25.14	25.97	9.81	10.77	9.81	9.81	10.77
Total CO ₂ emissions per m ² (kg of CO ₂ /kWh/m ²)	16.40	16.75	16.40	16.40	16.75	2.91	2.91	2.91	2.91	2.91
Energy saved (%)		-2.13%	0.00%	0.00%	-2.13%		0.03%	0.00%	0.00%	0.03%
CO ₂ emissions saved (%)		-2.13%	0.00%	0.00%	-2.13%		0.03%	0.00%	0.00%	0.03%

Table 4.15 Comparison of Electricity demands for heating and cooling per m² in Variations based on Scenario 1 with no electricity production

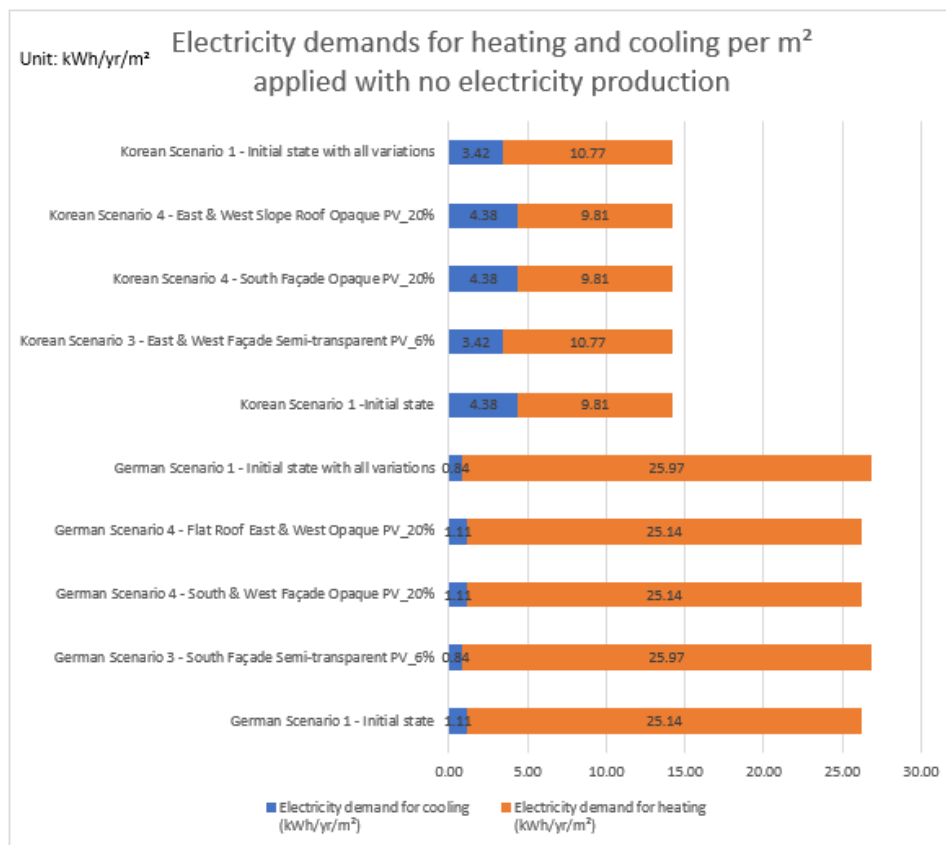


Figure 4.19 Comparison of Electricity demands for heating and cooling per m² in Variations based on Scenario 1 with no electricity production

4.2.3 Variations based on Scenario 2 with no Electricity production

The electricity demands of variations based on Scenario 2 with no electricity production are shown in Table 4.16 and Figure 4.20. In the variation with semi-transparent PV modules, the annual electricity requirements for heating and cooling rose by 0.16 kWh/m² compared with the renovated state. The demand for cooling decreased as 0.28 kWh/m² while 0.44 kWh/m² for heating rose. The electricity demand rose by 1.35%. The variant with semi-transparent PVs in the Korean model saved by 0.19 kWh/m². This gives a 1.69% savings on annual electricity consumption.

based on Scenario 2 applied with no electricity production	German Model					Korean Model				
	Scenario 2 - Renovated state	Scenario 3 - South Facade Semi-transparent PV_6%	Scenario 4 - South & West Facade Opaque PV_20%	Scenario 4 - Flat Roof East & West Opaque PV_20%	Scenario 2 - Renovated state with all variations	Scenario 2 - Renovated state	Scenario 3 - East & West Facade Semi-transparent PV_6%	Scenario 4 - South Facade Opaque PV_20%	Scenario 4 - East & West Slope Roof Opaque PV_20%	Scenario 2 - Renovated state with all variations
Electricity demand per m ² living area (kWh/yr/m ²)	11.76	11.92	11.76	11.76	11.92	11.15	10.96	11.15	11.15	10.96
Electricity demand for cooling (kWh/yr/m ²)	1.38	1.10	1.38	1.38	1.10	4.46	3.49	4.46	4.46	3.49
Electricity demand for heating (kWh/yr/m ²)	10.38	10.82	10.38	10.38	10.82	6.69	7.47	6.69	6.69	7.47
Total CO ₂ emissions per m ² (kg of CO ₂ /kWh/m ²)	7.35	7.45	7.35	7.35	7.45	2.29	2.25	2.29	2.29	2.25
Energy saved (%)		-1.35%	0.00%	0.00%	-1.35%		1.69%	0.00%	0.00%	1.69%
CO ₂ emissions saved (%)		-1.35%	0.00%	0.00%	-1.35%		1.69%	0.00%	0.00%	1.69%

Table 4.16 Comparison of Electricity demands for heating and cooling per m² in Variations based on Scenario 2 with no electricity production

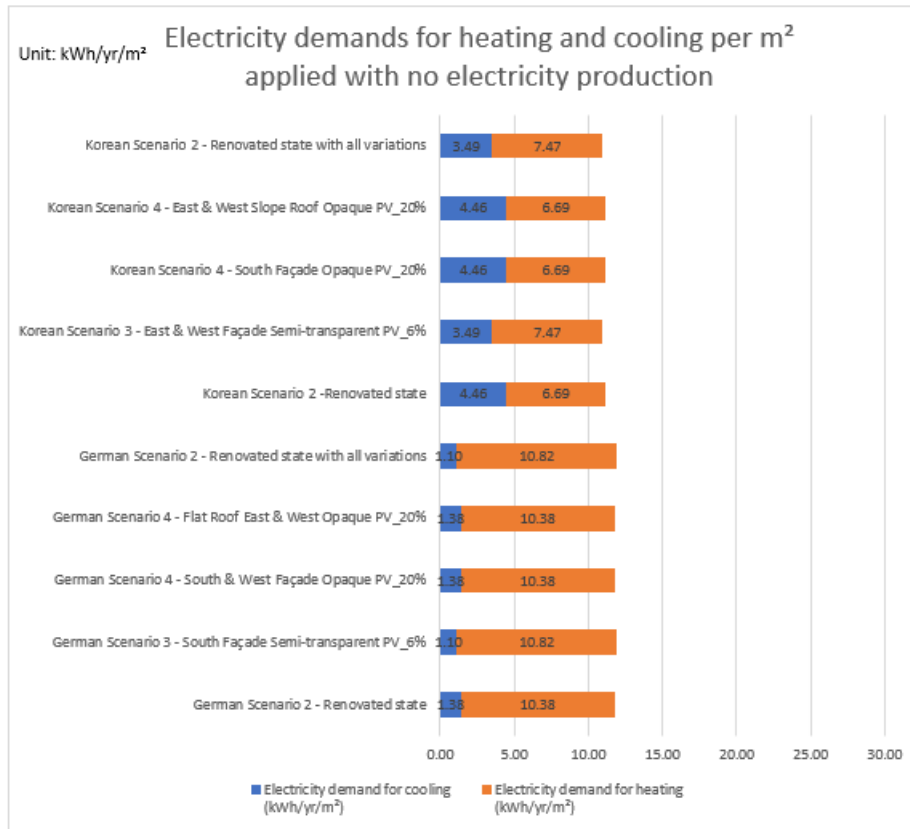


Figure 4.20 Comparison of Electricity demands for heating and cooling per m² in Variations based on Scenario 2 with no electricity production

4.2.4 Variations based on Scenario 1 with Electricity production

The electricity demands of variations from Scenario 1 with power production are shown in Table 4.17 and Figure 4.21. Compared to chapters 4.2.2 and 4.2.3, the difference of results is to be applied hourly electricity generated from PV modules so the annual electricity demand per m² was calculated with the subtraction of the electricity demand for heating and cooling and in-house electricity consumption generated from PV modules by an hour. Totally the electricity demand in all variants decreased from 0.61% to 44.13% compared with the initial state in Scenario 1 and the energy ratio saved is much higher in the Korean model. The electricity demand per m² in the German model applied semi-transparent PV modules decreased to 0.16 kWh/m², which gives a 0.61% savings and the minimum value of all variants while that in the Korean model with the same condition diminished to 3.06 kWh/m², which saves the energy of 21.56%. Because the window area applied semi-transparent PV modules is 18 times as big as the area in the German model. And the saved energy with all variations in the Korean model is 44.13% which is the maximum in all cases and around twice as high as that in the German model.

based on Scenario 1 with electricity production	German Model					Korean Model				
	Scenario 1 - Initial state	Scenario 3 - South Façade Semi-transparent PV_6%	Scenario 4 - South & West Façade Opaque PV_20%	Scenario 4 - Flat Roof East & West Opaque PV_20%	Scenario 1 - Initial state with all variations	Scenario 1 - Initial state	Scenario 3 - East & West Façade Semi-transparent PV_6%	Scenario 4 - South Façade Opaque PV_20%	Scenario 4 - East & West Slope Roof Opaque PV_20%	Scenario 1 - Initial state with all variations
Electricity demand per m ² living area after In-house consumption of PV (kWh/yr/m ²)	26.25	26.09	21.78	21.42	20.24	14.19	11.13	8.43	9.89	7.93
Total CO ₂ emissions per m ² (kg of CO ₂ /kWh/m ²)	16.40	16.30	13.61	13.39	12.64	2.91	2.28	1.73	2.03	1.63
Energy saved (%)		0.61%	17.02%	18.39%	22.91%		21.56%	40.62%	30.29%	44.13%
CO ₂ emissions saved (%)		0.61%	17.02%	18.39%	22.91%		21.56%	40.62%	30.29%	44.13%

Table 4.17 Comparison of Electricity demands per m² in Variations based on Scenario 1 with electricity production

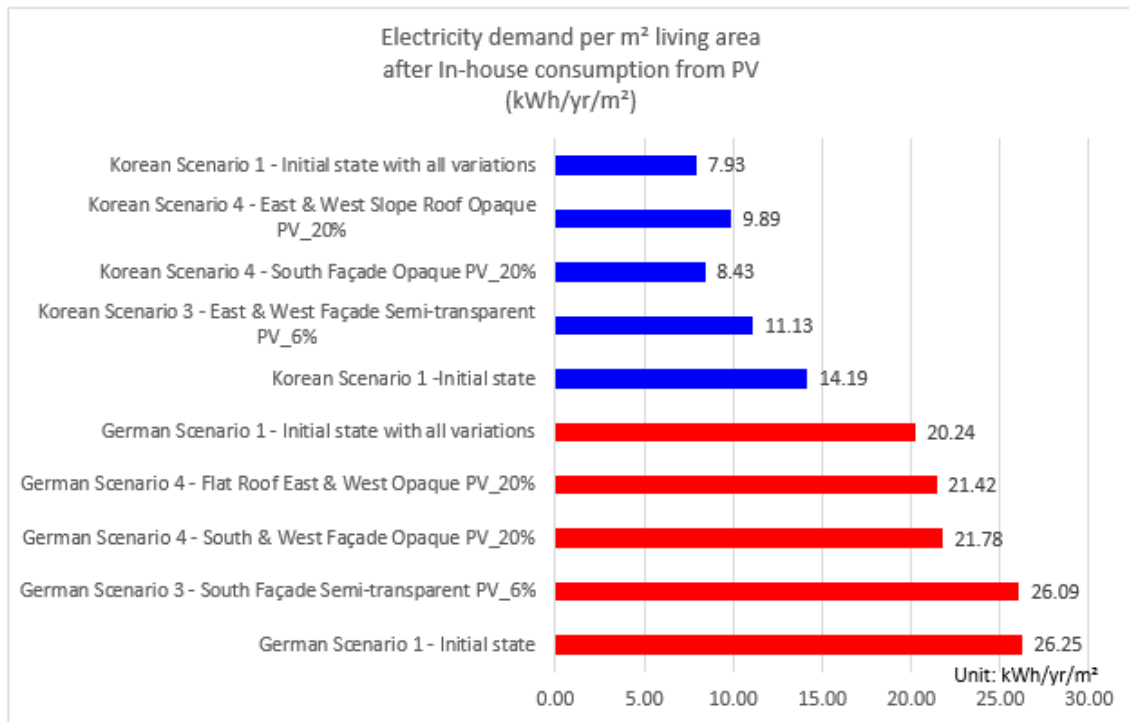


Figure 4.21 Comparison of Electricity demands per m² in Variations based on Scenario 1 with electricity production

4.2.5 Variations based on Scenario 2 with Electricity production

Figure 4.19 Table 4.18 and Figure 4.22 indicate the electricity demands of variations from Scenario 2 with electricity generated. The electricity requirement in all variants overall saved from 4.30% to 47.60% compared with the renovated state in Scenario 2. The energy

ratio saved increased compared to the previous chapter based on Scenario 1. The electricity demand per m² in the German model with semi-transparent PV modules diminished to 0.51 kWh/m² and saved 0.61%. The value is still the minimum of all variants whilst the maximum value saved the energy demand is 47.60% in the Korean model.

based on Scenario 2 with electricity production	German Model					Korean Model				
	Scenario 2 - Renovated state	Scenario 3 - South Façade Semi-transparent PV_6%	Scenario 4 - South & West Façade Opaque PV_20%	Scenario 4 - Flat Roof East & West Opaque PV_20%	Scenario 2 - Renovated state with all variations	Scenario 2 - Renovated state	Scenario 3 - East & West Façade Semi-transparent PV_6%	Scenario 4 - South Façade Opaque PV_20%	Scenario 4 - East & West Slope Roof Opaque PV_20%	Scenario 2 - Renovated state with all variations
Electricity demand per m ² living area after In-house consumption of PV (kWh/yr/m ²)	11.76	11.25	8.69	8.46	7.98	11.15	8.06	6.29	7.23	5.84
Total CO2 emissions per m ² (kg of CO2/kWh/m ²)	7.35	7.03	5.43	5.29	4.98	2.29	1.65	1.29	1.48	1.20
Energy saved (%)		4.30%	26.06%	28.01%	32.16%		27.67%	43.57%	35.16%	47.60%
CO2 emissions saved (%)		4.30%	26.06%	28.01%	32.16%		27.67%	43.57%	35.16%	47.60%

Table 4.18 Comparison of Electricity demands per m² in Variations based on Scenario 2 with electricity production

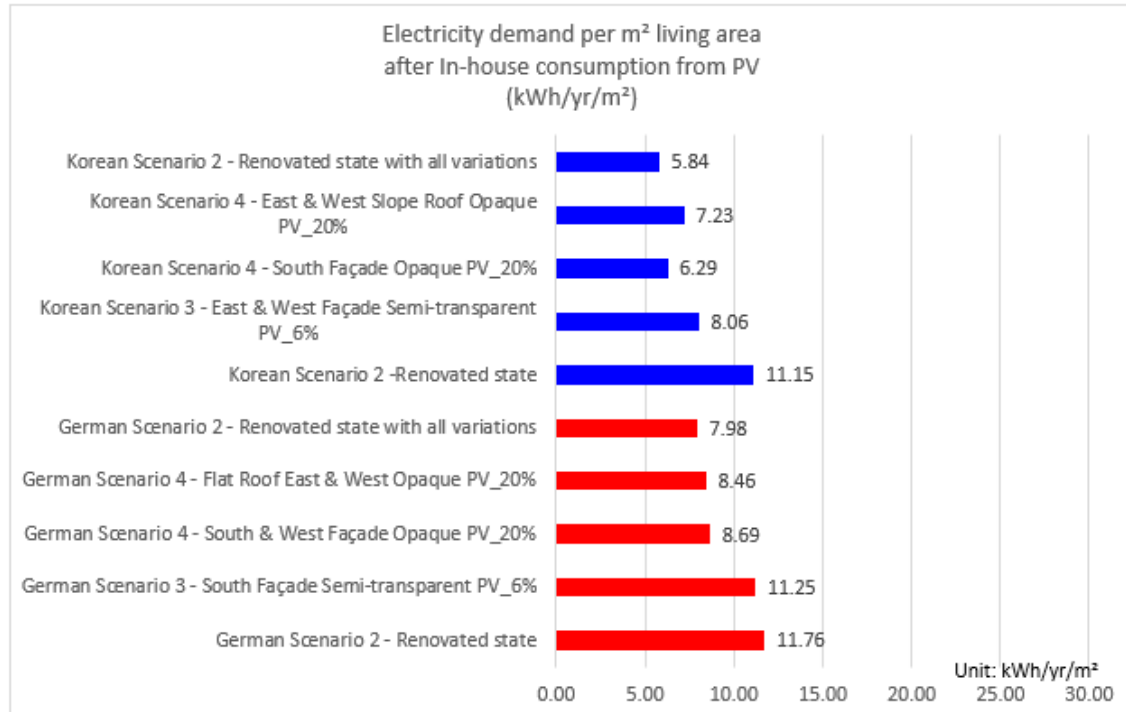


Figure 4.22 Comparison of Electricity demands per m² in Variations based on Scenario 2 with electricity production

4.2.6 Scenario 1 and Variations based on Scenario 2 with Electricity production

Table 4.19 and Figure 4.23 compare the electricity demands of Scenario 1 and variations based on Scenario 2 with electricity generated, which show how efficient the variants applied renovation and electricity production are compared to the initial state. The electricity requirement in all variants based on Scenario 2 decreased from 57.14% to 69.61% in the German model. And that in the Korean model is also reduced from 43.18% to 58.83%. Therefore, the electricity demands in the variants renovated in both models are saved to 43.18% or more compared with the early models.

	German Model					Korean Model				
	Initial state	Renovated state (based on Scenario 2)				Initial state	Renovated state (based on Scenario 2)			
	Scenario 1	Scenario 3 - South Façade Semi-transparent PV_6%	Scenario 4 - South & West Façade Opaque PV_20%	Scenario 4 - Flat Roof East & West Opaque PV_20%	Scenario 2 - Renovated state with all variations	Scenario 1	Scenario 3 - East & West Façade Semi-transparent PV_6%	Scenario 4 - South Façade Opaque PV_20%	Scenario 4 - East & West Slope Roof Opaque PV_20%	Scenario 2 - Renovated state with all variations
Electricity demand per m ² living area after In-house consumption of PV (kWh/yr/m ²)	26.25	11.25	8.69	8.46	7.98	14.19	8.06	6.29	7.23	5.84
Total CO ₂ emissions per m ² (kg of CO ₂ /kWh/m ²)	16.40	7.03	5.43	5.29	4.98	2.91	1.65	1.29	1.48	1.20
Energy saved (%)		57.14%	66.88%	67.75%	69.61%		43.18%	55.67%	49.06%	58.83%
CO ₂ emissions saved (%)		57.14%	66.88%	67.75%	69.61%		43.18%	55.67%	49.06%	58.83%

Table 4.19 Comparison of Electricity demands per m² in Scenario 1 and Variations based on Scenario 2

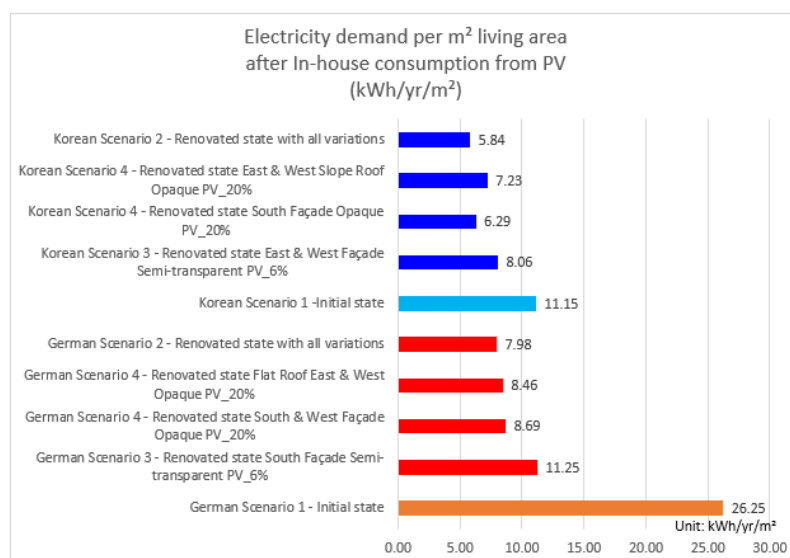


Figure 4.23 Comparison of Electricity demands per m² in Scenario 1 and Variations based on Scenario 2

4.2.7 Electricity Production fed into Grid and Electricity demand for Internal loads

There is each electricity production which is generated from solar modules and fed into the grid and the electricity demand for internal loads in Table 4.20 and Figure 4.24. This analysis is compared simply using the subtraction of the total electricity production amount and the electricity demand for internal loads unlike the previous analyses using hourly results. That's why this thesis is focused on comparisons of the electricity demands for heating and cooling for both models under all variants. Internal loads are the same in all variants based on Scenario 1 and 2 because the parameter for internal loads was fixed by one value for both models.

Type	Electricity production from PV system fed into the grid (kWh/a)	Electricity demand for Internal loads (equipment, lights, occupancy) (kWh/a)	Energy Saved (%)
German Model	Scenario 1 - Initial state	0	0%
	Scenario 3 - South Facade Semi-transparent PV_6% based on Scenario 1	302	1%
	Scenario 4 - South & West Facade Opaque PV_20% based on Scenario 1	11706	29%
	Scenario 4 - Flat Roof East & West Opaque PV_20% based on Scenario 1	22376	55%
	Scenario 1 - Initial state with all variations	39891	98%
	Scenario 2 - Renovated state	0	0%
	Scenario 3 - South Facade Semi-transparent PV_6% based on Scenario 2	389	1%
	Scenario 4 - South & West Facade Opaque PV_20% based on Scenario 2	13952	34%
	Scenario 4 - Flat Roof East & West Opaque PV_20% based on Scenario 2	24833	61%
	Scenario 2 - Renovated state with all variations	44107	109%
Korean Model	Scenario 1 - Initial state	0	0%
	Scenario 3 - South Facade Semi-transparent PV_6% based on Scenario 1	12140	11%
	Scenario 4 - South & West Facade Opaque PV_20% based on Scenario 1	89430	80%
	Scenario 4 - Flat Roof East & West Opaque PV_20% based on Scenario 1	32785	29%
	Scenario 1 - Initial state with all variations	167797	150%
	Scenario 2 - Renovated state	0	0%
	Scenario 3 - South Facade Semi-transparent PV_6% based on Scenario 2	12925	12%
	Scenario 4 - South & West Facade Opaque PV_20% based on Scenario 2	93855	84%
	Scenario 4 - Flat Roof East & West Opaque PV_20% based on Scenario 2	34633	31%
	Scenario 2 - Renovated state with all variations	173359	155%

Table 4.20 Electricity from PV modules fed into grid and Internal loads in 20 variations

Extra electricity demand for internal loads except for heating and cooling is 40564 kWh for the German model and 112043 kWh is for the Korean model. After energy consumption at

home, there is extra electricity production fed into the grid by grid-connected systems. The values in 20 variants are different because of hourly energy consumption used at home. The saving from values of subtraction is from 0% in the state applied no PV modules to 109% for the German model and 155% for the Korean model with all kinds of PV modules.

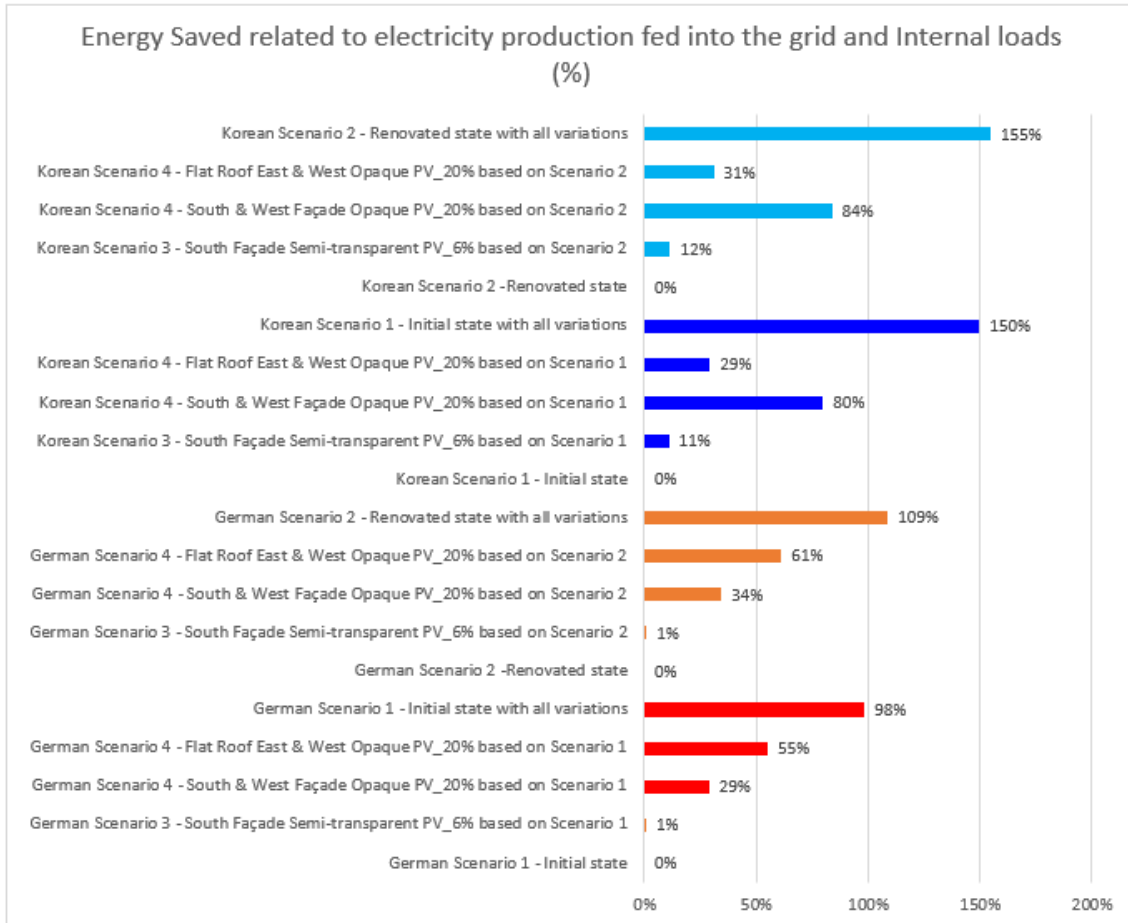


Figure 4.24 Electricity from PV modules fed into grid and Internal loads in 16 variations

5 Conclusion and Future Work

5.1 Conclusion

This thesis provides solar technologies in terms of definition, function, and comparisons between both countries about construction and energy as well as energy simulations for a typical German and Korean Multi-Family House in Dresden and Seoul. The main aim was to compare energy efficiency in both models and to improve the energy performance using semi-transparent and opaque PV modules on the façades and walls.

The energy performance in the German and Korean models can be seen low because the construction details from the current state and the German building was constructed 30 years or more and the Korean model was built in 1999. The main goal was to look for optimal ways to enhance the energy performance for the models. Thus, not only to reduce energy demands but also to produce energy were required for the best energy performance. Improved insulations and windows were for reducing the energy demands for heating and cooling and applying semi-transparent and opaque PV modules was for producing the electricity. These PV modules were installed on windows and walls and roofs for finding out the best solutions for rising the production under different directions and conditions. And the results were analyzed by hourly electricity generated by grid-connected systems.

The analysis of the electricity demand for heating and cooling indicated the energy efficiency in the current state of the German model was 85% lower than that of the Korean model. The annual electricity demand for heating and cooling for m^2 is 26.25 kWh/ m^2 in the German residential building and 14.19 kWh/ m^2 in the Korean residential building. After the renovation according to German energy-saving standard for version 2014 (BRD 2013) and Korean standards for energy saving in buildings, the German model saved the energy of 55% while the Korean model saved 21%. And the CO₂ emissions per m^2 decreased from 10.53 to 4.72 kg of CO₂, leading to 55% less of CO₂ for the German model as well as those in the Korean model also are reduced from 6.98 to 5.49 kg of CO₂, leading to 21% less of CO₂.

The analysis showed that the electricity demands for heating and cooling under conditions with or without applying semi-transparent PV modules were different in the initial and renovated states for both models. The demand rose as 2.13% for the German model with semi-transparent PV modules while that decreased as 0.03% for the Korean model with the same condition in the early state. The demand also rose as 1.35% for the German model and reduced as 1.69% for the Korean model under the previous condition in the renovated state.

The simulation with semi-transparent PV modules could have errors in terms of the electricity demands for heating and cooling and the changes in indoor daylight. IDA ICE did not have the function of energy simulations with semi-transparent PV modules. So the analysis

above was started from SHGC and transmittance assumption using 50% transparency of the semi-transparent PV modules. But the simulation results would be expected that the errors from the assumption would be not big because the total area applied semi-transparent solar modules in the German model were 28.35 m² and only 12 windows facing south in the rooms were combined as well as in the Korean model the solar modules were installed on the east and west facades in the balconies where did not use any heater and cooler. Therefore the electricity demands would not have big errors as much as the conclusion should be changed.

The results of indoor daylight present that monthly average illuminance in the zone combined semi-transparent PV modules after the renovation was reduced from 338.3 to 141 Lux in December compared with the early state of the German model, which is enough bright for indoor activities. And the value of one zone connected to balconies with semi-transparent PV modules in the Korean model also decreased from 47.27 to 28.29 Lux in December but the daylight in the early state was fundamentally not enough for indoor activities. Hence, the daylight in the German model was sufficient although the solar transmittance was reduced as 58 % and that in both the early state and renovated state with semi-transparent solar modules were insufficient for the Korean model.

The analysis indicated that the ways with any case applying solar modules in the renovated state of both models proved to be the better solutions for improving energy performance. The electricity demand for heating and cooling for m² is 11.25 kWh/m² with semi-transparent PV modules, 8.69 kWh/m² with opaque PV modules on the walls, 8.46 kWh/m² with opaque PV modules on the roof, and 7.98 kWh/m² with all variations in the German residential building. These values saved 57.14%, 66.88%, 67.75%, and 69.61% of the electricity demand and CO₂ emissions compared to the initial state in the German building. Also, the electricity demand per m² in the Korean model is 8.06 kWh/m² with semi-transparent PV modules, 6.29 kWh/m² with opaque PV modules on the walls, 7.23 kWh/m² with opaque PV modules on the roof, and 5.84 kWh/m² with all variations. The saving ratios were 43.18%, 55.67%, 49.06%, and 58.83%.

As the result, this thesis can be regarded as an optimal strategy for improving energy performance and decreasing CO₂ emissions as much as 67% for the German target and as 32.7% for the Korean target in the building sector by 2030.

5.2 Future Work

Further work is needed to undertake with the functionality which simulates for semi-transparent solar modules for the exact results.

And work is also needed to compare both models applying semi-transparent PV modules and shadings for improving energy efficiency. So the result is needed to compare which of the two cases is more efficient in terms of energy performance.

6 References

- [1] „The Paris Agreement,“ United Nations Framework Convention on Climate Change, 2016. [Online]. Available: <https://unfccc.int/process-and-meetings/the-paris-agreement/the-paris-agreement>. [Zugriff am 15 June 2020].
- [2] "Climate Action Plan 2050," Federal Ministry for the Environment, Nature Conservation and Nuclear Safety, 2016. [Online]. Available: <https://www.bmu.de/en/topics/climate-energy/climate/national-climate-policy/greenhouse-gas-neutral-germany-2050/>. [Accessed 15 June 2020].
- [3] „Act on Low Carbon. Green Growth,“ 2010. [Online]. Available: <http://www.law.go.kr/lsInfoP.do?lsiSeq=211627&efYd=20200527#0000>. [Zugriff am 15 June 2020].
- [4] "2030 Korean Greenhouse Gas Reduction Roadmap Revision," Korean Ministry of Environment, 2018.
- [5] "Fraunhofer," June 2017. [Online]. Available: https://www.isi.fraunhofer.de/content/dam/isi/dokumente/cce/2017/29882_Brochure_Heating-and-Cooling_web.pdf. [Accessed 11 July 2020].
- [6] A. Luque and S. Hegedus, Handbook of photovoltaic science and engineering, John Wiley & Sons, 2003.
- [7] K. Mertens, Photovoltaics: fundamentals, technology, and practice, John Wiley & Sons, 2014.
- [8] "New & Renewable Energy White Paper," Ministry of Trade, Industry and Energy & Korea Energy Agency, 2018.
- [9] T. Ibn-Mohammed, S. Koh, I. Reaney, A. Acquaye, G. Schileo, K. Mustapha and R. Greenough, "Perovskite solar cells: An integrated hybrid lifecycle assessment and review in comparison with other photovoltaic technologies," *Renewable and Sustainable Energy Reviews*, vol. 80, pp. 1321-1344, 2017.
- [10] Y. Zhou, Eco-and renewable energy materials, 2015.
- [11] J. Kilner, S. J. Skinner, S. Irvine and P. Edwards, Functional materials for sustainable energy applications, Elsevier, 2012.
- [12] R. Schmalensee, „The future of solar energy: an interdisciplinary MIT study,“ Energy Initiative, Massachusetts Institute of Technology, 2015.
- [13] A. Metz, M. Fischer, G. Xing, L. Yong and S. Julsrud, "International Technology Roadmap for Photovoltaic (ITRPV), 2013 Results," 2013.

- [1 Y. H. Jang, „A Study on the Types of Public Facilities Design Based on the Status of PV
4] System,“ *The Korean Society Of Design Culture*, Bd. 25, Nr. 2, pp. 519-530, 2019.
- [1 F. Staiss, "Photovoltaic," *Vieweg, & Sohn, Braunschweig/Wiesbaden*, p. 14, 1995.
5]
- [1 "Statistische Mitteilungen Bauen und Wohnen 2018," 2018. [Online]. Available:
6] [https://www.dresden.de/de/leben/stadtportrait/statistik/bauen-wohnen-
verkehr/Gebaeude-_und_Wohnungsbestand.php](https://www.dresden.de/de/leben/stadtportrait/statistik/bauen-wohnen-verkehr/Gebaeude-_und_Wohnungsbestand.php). [Accessed 16 June 2020].
- [1 "Building Status Statistics as of 2018," 2018. [Online]. Available:
7] http://www.molit.go.kr/USR/NEWS/m_71/dtl.jsp?lcmspage=1&id=95081898.
[Accessed 16 June 2020].
- [1 „old house,“ Wuestenrot Online, [Online]. Available:
8] [https://www.wuestenrot.de/de/ihr_wohnwunsch/eine_immobilie_kaufen/baujahr-
haus.html/](https://www.wuestenrot.de/de/ihr_wohnwunsch/eine_immobilie_kaufen/baujahr-haus.html/). [Zugriff am 16 June 2020].
- [1 "BP Statistical Review of World Energy 2019," 2019. [Online]. Available:
9] [https://www.bp.com/content/dam/bp/business-
sites/en/global/corporate/pdfs/energy-economics/statistical-review/bp-stats-
review-2019-full-report.pdf](https://www.bp.com/content/dam/bp/business-sites/en/global/corporate/pdfs/energy-economics/statistical-review/bp-stats-review-2019-full-report.pdf). [Accessed 16 June 2020].
- [2 "Deutsche Gesellschaft für Nachhaltiges Bauen system," DGNB GmbH, [Online].
0] Available: <https://www.dgnb-system.de/de/>. [Accessed 16 June 2020].
- [2 „Green Standard for Energy and Environmental Design,“ Ministry of Land,
1] Infrastructure and Transport, Ministry of Environment, [Online]. Available:
<http://gseed.greentogogether.go.kr/>. [Zugriff am 16 June 2020].
- [2 „EnEV erhöht den Neubau-Standard ab 2016,“ EnEV, [Online]. Available: [https://enev-
2\] online.com/enev_praxishilfen/vergleich_enev_2016_enev_2014_neubau_wohnbau_3_
primaerenergiebedarf_15.07.20.htm](https://enev-online.com/enev_praxishilfen/vergleich_enev_2016_enev_2014_neubau_wohnbau_3_primaerenergiebedarf_15.07.20.htm). [Zugriff am 16 June 2020].
- [2 „ZEB,“ Korea Energy Agency, [Online]. Available:
3] <https://zeb.energy.or.kr/introduceZero/introduce.aspx>. [Zugriff am 16 June 2020].
- [2 „EEWärmeG 2011,“ ENEV-ONLINE, 2011. [Online]. Available: [https://enev-
4\] online.de/eewaermeg/2011/](https://enev-online.de/eewaermeg/2011/). [Zugriff am 16 June 2020].
- [2 „IDA ICE,“ EQUA, [Online]. Available: <https://www.equa.se/en/>. [Zugriff am 16 June
5] 2020].
- [2 D. B. Crawley, J. W. Hand, M. Kummert and B. T. Griffith, "Contrasting the capabilities of
6] building energy performance simulation programs," *Building and environment*, vol. 43,
no. 4, pp. 661-673, 2008.
- [2 C. Schünemann, A. Olfert, D. Schiela, K. Gruhler and R. Ortlepp, "Mitigation and
7] adaptation in multifamily housing: overheating and climate justice,," *Buildings and
Cities*, vol. 1, no. 1, pp. 36-55, 2020.

- [2] „Naver,“ [Online]. Available: <https://new.land.naver.com/complexes?ms=37.537809,126.952162,19&a=APT:JGC:ABYG&e=RETAIL>. [Zugriff am 16 June 2020].
- [2] *Design specification of H apartment in Seoul*.
9]
- [3] *Design specification of P apartment in Incheon*.
0]
- [3] "Polysolar," [Online]. Available: [https://polysolar.com/Datasheets/PS-CT-1\] Transparent%20Technical%20Specification%20Sheet.pdf](https://polysolar.com/Datasheets/PS-CT-1] Transparent%20Technical%20Specification%20Sheet.pdf). [Accessed 24 June 2020].
- [3] „doopedia,“ [Online]. Available: <http://www.doopedia.co.kr>. [Zugriff am 25 June 2020].
2]
- [3] „LG,“ [Online]. Available: [https://www.lge.co.kr/kr/business/product/energy/lg-3\] LG370Q1C-V5](https://www.lge.co.kr/kr/business/product/energy/lg-3] LG370Q1C-V5) . [Zugriff am 30 April 2020].
- [3] „K2 Systems,“ [Online]. Available: [https://k2-systems.com/en/products/mounting-4\] systems-flat-roofs](https://k2-systems.com/en/products/mounting-4] systems-flat-roofs). [Zugriff am 25 June 2020].
- [3] „Statista,“ 2020. [Online]. Available: <https://de.statista.com/statistik/daten/studie/38897/umfrage/co2-emissionsfaktor-fuer-den-strommix-in-deutschland-seit-1990/>. [Zugriff am 30 June 2020].
- [3] „Climate Transparency,“ 2018. [Online]. Available: [https://www.climate-6\] transparency.org/wp-content/uploads/2019/01/BROWN-TO-GREEN_2018_South_Korea_FINAL.pdf](https://www.climate-6] transparency.org/wp-content/uploads/2019/01/BROWN-TO-GREEN_2018_South_Korea_FINAL.pdf). [Zugriff am 30 June 2020].
- [3] D. L. DiLaura, K. Houser, R. Mistrick and G. R. Steffy, *The Lighting Handbook: Reference 7] and Application*, New York : Illuminating Engineering Society of North America, 2011.
- [3] "TARCOG: MATHEMATICAL MODELS FOR CALCULATION OF THERMAL 8] PERFORMANCE OF GLAZING SYSTEMS WITH OR WITHOUT SHADING DEVICES," Carli, Inc. is Your Building Energy Systems and Technology Choice, 2006.
- [3] W. Hwang, H. J. Seo und M. C. Lee, „Comparison on the CO Emission Indices with Respect 9] to Fuels for Power Generation in Korea based on Statistical Data,“ in *The Korean Society of Mechanical Engineers*, 2018.
- [4] „Convenant of Mayors for Climate & Energy,“ [Online]. Available: https://www.eumayors.eu/IMG/pdf/technical_annex_en.pdf. [Zugriff am 28 June 2020].

7 Appendix/Appendices

7.1 Variations based on Scenario 1

7.1.1 South windows with semi-transparent PV modules based on Scenario 1 in the German model

Month	PV production per the whole area 28.35m ²	Energy demand for cooling	Electricity demand for cooling with compression cooling machine with annual COP of 3	Energy demand for heating	Electricity demand for heating with Ground source heat pump with annual COP of 3	Electricity demand for heating and cooling	In-house consumption of PV	Electricity from PV system feeding into the grid	Remaining electricity demand from the grid for heating and cooling
SUM(kWh)	1453	4018	1339	124704	41568	42908	1150	302	41757
January	58	0	0	23219	7740	7740	58	0	7682
February	92	0	0	20375	6792	6792	92	0	6700
March	126	0	0	16482	5494	5494	126	0	5368
April	142	2	1	9032	3011	3011	139	3	2873
May	163	169	56	3455	1152	1208	104	59	1104
June	131	534	178	599	200	378	78	53	300
July	155	1317	439	24	8	447	101	54	346
August	168	1980	660	187	62	722	114	54	608
September	139	17	6	2265	755	761	72	67	689
October	150	0	0	7474	2491	2491	137	13	2354
November	69	0	0	18743	6248	6248	69	0	6178
December	61	0	0	22849	7616	7616	61	0	7555

7.1.2 South and West walls with opaque PV modules based on Scenario 1 in the German model

Month	PV production per 1m ²	PV production per the whole area 128.39m ²	Energy demand for cooling	Electricity demand for cooling with compression cooling machine with annual COP of 3	Energy demand for heating	Electricity demand for heating with Ground source heat pump with annual COP of 3	Electricity demand for heating and cooling	In-house consumption of PV	Electricity from PV system feeding into the grid	Remaining electricity demand from the grid for heating and cooling
SUM(kWh)	154.32	18857	5335	1778	120700	40233	42012	7150	11706	34861
January	4.91	522	0	0	22917	7639	7639	522	0	7117
February	8.18	900	0	0	19923	6641	6641	884	16	5757
March	12.64	1495	3	1	15935	5312	5313	1059	436	4254
April	16.21	2056	5	2	8435	2812	2813	1013	1044	1801
May	19.96	2607	274	91	3189	1063	1155	522	2085	633
June	16.43	2173	741	247	486	162	409	273	1899	136
July	19.20	2523	1759	586	19	6	593	434	2089	159
August	19.18	2430	2478	826	158	53	879	505	1925	373
September	13.73	1613	63	21	1952	651	671	246	1367	426
October	13.13	1425	11	4	6817	2272	2276	596	829	1680
November	5.84	617	0	0	18332	6111	6111	601	17	5510
December	4.90	497	0	0	22536	7512	7512	497	0	7015

7.1.3 East and West slope roofs with opaque PV modules based on Scenario 1 in the German model

Month	PV production per 1m ²	PV production per the whole area 173.68MWh	Energy demand for cooling	Electricity demand for cooling with compression cooling machine with annual COP of 3	Energy demand for heating	Electricity demand for heating with Ground source heat pump with annual COP of 3	Electricity demand for heating and cooling	In-house consumption of PV	Electricity from PV system feeding into the grid	Remaining electricity demand from the grid for heating and cooling
SUM(kWh)	173.33	30104	5335	1778	120700	40233	42012	7727	22376	34284
January	3.27	569	0	0	22917	7639	7639	569	0	7070
February	6.03	1047	0	0	19923	6641	6641	989	58	5652
March	12.32	2141	3	1	15935	5312	5313	1282	859	4031
April	18.35	3187	5	2	8435	2812	2813	1044	2143	1770
May	27.68	4807	274	91	3189	1063	1155	528	4279	626
June	23.62	4101	741	247	486	162	409	294	3808	115
July	27.51	4778	1759	586	19	6	593	481	4297	111
August	23.91	4153	2478	826	158	53	879	590	3563	289
September	14.35	2493	63	21	1952	651	671	247	2245	424
October	9.72	1688	11	4	6817	2272	2276	577	1111	1699
November	3.91	679	0	0	18332	6111	6111	665	13	5446
December	2.65	461	0	0	22536	7512	7512	461	0	7051

7.1.4 Scenario 1 with all variations in the German model

Month	PV production per 1m ²	PV production per the whole area 330.42MWh	Energy demand for cooling	Electricity demand for cooling with compression cooling machine with annual COP of 3	Energy demand for heating	Electricity demand for heating with Ground source heat pump with annual COP of 3	Electricity demand for heating and cooling	In-house consumption of PV	Electricity from PV system feeding into the grid	Remaining electricity demand from the grid for heating and cooling
SUM(kWh)		50413	4018	1339	124704	41568	42908	10522	39891	32385
January		1148	0	0	23219	7740	7740	1102	46	6638
February		2038	0	0	20375	6792	6792	1539	499	5253
March		3762	0	0	16482	5494	5494	1735	2027	3759
April		5385	2	1	9032	3011	3011	1301	4084	1710
May		7577	169	56	3455	1152	1208	610	6967	598
June		6405	534	178	599	200	378	273	6132	105
July		7456	1317	439	24	8	447	381	7075	66
August		6751	1980	660	187	62	722	505	6246	217
September		4244	17	6	2265	755	761	304	3941	457
October		3263	0	0	7474	2491	2491	759	2504	1733
November		1365	0	0	18743	6248	6248	1075	290	5173
December		1019	0	0	22849	7616	7616	939	80	6677

7.1.5 East and West windows with semi-transparent PV modules based on Scenario 1 in the Korean model

Month	PV production per 1m ²	PV production per the whole area 534.6m ²	Energy demand for cooling	Electricity demand for cooling with compression cooling machine with annual COP of 3	Energy demand for heating	Electricity demand for heating with Ground source heat pump with annual COP of 3	Electricity demand for heating and cooling	In-house consumption of PV	Electricity from PV system feeding into the grid	Remaining electricity demand from the grid for heating and cooling
SUM(kWh)	50.58	27038	49962	16654	157489	52496	69150	14898	12140	54252
January	2.61	1398	0	0	43580	14527	14527	1398	0	13129
February	3.09	1652	0	0	31978	10659	10659	1652	0	9007
March	4.91	2625	0	0	21265	7088	7088	2087	538	5001
April	5.81	3105	0	0	4782	1594	1594	619	2486	975
May	6.47	3461	951	317	13	4	321	209	3252	113
June	4.99	2668	6942	2314	0	0	2314	1190	1478	1124
July	4.42	2363	15391	5130	0	0	5130	1817	546	3314
August	4.66	2490	20085	6695	0	0	6695	2246	244	4449
September	4.11	2199	6584	2195	0	0	2195	983	1216	1211
October	4.12	2200	10	3	1588	529	533	194	2006	338
November	2.93	1567	0	0	18810	6270	6270	1194	373	5076
December	2.45	1310	0	0	35473	11824	11824	1310	0	10514

7.1.6 South walls with opaque PV modules based on Scenario 1 in the Korean model

Month	PV production per 1m ²	PV production per the whole area 575.64m ²	Energy demand for cooling	Electricity demand for cooling with compression cooling machine with annual COP of 3	Energy demand for heating	Electricity demand for heating with Ground source heat pump with annual COP of 3	Electricity demand for heating and cooling	In-house consumption of PV	Electricity from PV system feeding into the grid	Remaining electricity demand from the grid for heating and cooling
SUM(kWh)	204.17	117527	64016	21339	143488	47829	69168	28096	89430	41072
January	17.37	10000	0	0	41851	13950	13950	4538	5462	9413
February	17.55	10103	0	0	29934	9978	9978	3548	6555	6430
March	20.09	11566	0	0	17994	5998	5998	2339	9227	3659
April	18.90	10882	0	0	2606	869	869	345	10537	524
May	15.88	9144	3563	1188	1	0	1188	843	8301	344
June	12.94	7448	10117	3372	0	0	3372	2031	5417	1341
July	12.23	7039	18223	6074	0	0	6074	3118	3921	2957
August	14.29	8227	23060	7687	0	0	7687	3708	4519	3978
September	16.12	9279	8848	2949	0	0	2949	1577	7702	1372
October	21.71	12494	205	68	573	191	259	129	12366	131
November	19.53	11241	0	0	16772	5591	5591	1987	9254	3604
December	17.55	10103	0	0	33758	11253	11253	3934	6169	7319

7.1.7 East and West roofs with opaque PV modules based on Scenario 1 in the Korean model

Month	PV production per 1m ²	PV production per the whole area 231.98m ²	Energy demand for cooling	Electricity demand for cooling with compression cooling machine with annual COP of 3	Energy demand for heating	Electricity demand for heating with Ground source heat pump with annual COP of 3	Electricity demand for heating and cooling	In-house consumption of PV	Electricity from PV system feeding into the grid	Remaining electricity demand from the grid for heating and cooling
SUM(kWh)	231.64	53736	64016	21339	143488	47829	69168	20951	32785	48217
January	10.18	2361	0	0	41851	13950	13950	2336	25	11614
February	12.95	3005	0	0	29934	9978	9978	2526	478	7452
March	21.14	4904	0	0	17994	5998	5998	2009	2895	3989
April	28.33	6572	0	0	2606	869	869	330	6242	539
May	31.23	7244	3563	1188	1	0	1188	807	6437	381
June	25.84	5994	10117	3372	0	0	3372	1860	4133	1512
July	22.12	5133	18223	6074	0	0	6074	2691	2441	3383
August	22.46	5211	23060	7687	0	0	7687	3309	1903	4378
September	18.96	4399	8848	2949	0	0	2949	1427	2972	1522
October	17.28	4009	205	68	573	191	259	119	3890	140
November	11.62	2696	0	0	16772	5591	5591	1368	1328	4223
December	9.52	2208	0	0	33758	11253	11253	2169	40	9084

7.1.8 Scenario 1 with all variations in the Korean model

Month	PV production per 1m ²	PV production per the whole area 1342.22m ²	Energy demand for cooling	Electricity demand for cooling with compression cooling machine with annual COP of 3	Energy demand for heating	Electricity demand for heating with Ground source heat pump with annual COP of 3	Electricity demand for heating and cooling	In-house consumption of PV	Electricity from PV system feeding into the grid	Remaining electricity demand from the grid for heating and cooling
SUM(kWh)		198300	49962	16654	157489	52496	69150	30503	167797	38648
January		13758	0	0	43580	14527	14527	5308	8451	9219
February		14760	0	0	31978	10659	10659	4263	10497	6397
March		19094	0	0	21265	7088	7088	3163	15931	3925
April		20559	0	0	4782	1594	1594	747	19812	847
May		19849	951	317	13	4	321	239	19610	82
June		16110	6942	2314	0	0	2314	1535	14575	779
July		14534	15391	5130	0	0	5130	3051	11483	2079
August		15929	20085	6695	0	0	6695	3764	12165	2931
September		15878	6584	2195	0	0	2195	1309	14569	886
October		18704	10	3	1588	529	533	229	18475	304
November		15504	0	0	18810	6270	6270	2450	13054	3820
December		13622	0	0	35473	11824	11824	4445	9176	7379

7.2 Variations based on Scenario 2

7.2.1 South windows with semi-transparent PV modules based on Scenario 2 in the German model

Month	PV production per 1m ²	PV production per the whole area 28.35m ²	Energy demand for cooling	Electricity demand for cooling with compression cooling machine with annual COP of 3	Energy demand for heating	Electricity demand for heating with Ground source heat pump with annual COP of 3	Electricity demand for heating and cooling	In-house consumption of PV	Electricity from PV system feeding into the grid	Remaining electricity demand from the grid for heating and cooling
SUM(kWh)	51.24	1453	5270	1757	51946	17315	19072	1064	389	18008
January	2.04	58	0	0	10585	3528	3528	58	0	3471
February	3.24	92	0	0	9293	3098	3098	92	0	3006
March	4.46	126	0	0	7090	2363	2363	115	11	2248
April	4.99	142	0	0	3206	1069	1069	119	23	950
May	5.76	163	267	89	1138	379	469	90	73	378
June	4.61	131	888	296	55	18	314	92	38	222
July	5.46	155	1914	638	0	0	638	140	14	497
August	5.92	168	2118	706	0	0	706	129	39	577
September	4.89	139	82	27	84	28	55	24	114	31
October	5.29	150	1	0	1901	634	634	73	77	560
November	2.44	69	0	0	8207	2736	2736	69	0	2666
December	2.15	61	0	0	10386	3462	3462	61	0	3401

7.2.2 South and West walls with opaque PV modules based on Scenario 2 in the German model

Month	PV production per 1m ²	PV production per the whole area 128.39m ²	Energy demand for cooling	Electricity demand for cooling with compression cooling machine with annual COP of 3	Energy demand for heating	Electricity demand for heating with Ground source heat pump with annual COP of 3	Electricity demand for heating and cooling	In-house consumption of PV	Electricity from PV system feeding into the grid	Remaining electricity demand from the grid for heating and cooling
SUM(kWh)	154.32	18857	6632	2211	49820	16607	18817	4904	13952	13913
January	4.91	522	0	0	10391	3464	3464	475	47	2989
February	8.18	900	0	0	9008	3003	3003	636	264	2367
March	12.64	1495	0	0	6744	2248	2248	647	848	1601
April	16.21	2056	0	0	2838	946	946	404	1652	542
May	19.96	2607	393	131	1021	340	471	273	2333	198
June	16.43	2173	1151	384	46	15	399	302	1871	97
July	19.20	2523	2293	764	0	0	764	554	1969	210
August	19.18	2430	2523	841	0	0	841	525	1905	316
September	13.73	1613	220	73	68	23	96	74	1538	22
October	13.13	1425	52	17	1586	529	546	176	1249	370
November	5.84	617	0	0	7924	2641	2641	426	192	2216
December	4.90	497	0	0	10194	3398	3398	413	84	2985

7.2.3 East and West slope roofs with opaque PV modules based on Scenario 2 in the German model

Month	PV production per 1m ²	PV production per the whole area 173.68MWh	Energy demand for cooling	Electricity demand for cooling with compression cooling machine with annual COP of 3	Energy demand for heating	Electricity demand for heating with Ground source heat pump with annual COP of 3	Electricity demand for heating and cooling	In-house consumption of PV	Electricity from PV system feeding into the grid	Remaining electricity demand from the grid for heating and cooling
SUM(kWh)	173.33	30104	6632	2211	49820	16607	18817	5270	24833	13547
January	3.27	569	0	0	10391	3464	3464	528	41	2935
February	6.03	1047	0	0	9008	3003	3003	694	353	2309
March	12.32	2141	0	0	6744	2248	2248	720	1421	1528
April	18.35	3187	0	0	2838	946	946	396	2791	550
May	27.68	4807	393	131	1021	340	471	274	4533	197
June	23.62	4101	1151	384	46	15	399	321	3781	78
July	27.51	4778	2293	764	0	0	764	598	4180	166
August	23.91	4153	2523	841	0	0	841	588	3566	253
September	14.35	2493	220	73	68	23	96	77	2416	19
October	9.72	1688	52	17	1586	529	546	167	1521	379
November	3.91	679	0	0	7924	2641	2641	481	198	2161
December	2.65	461	0	0	10194	3398	3398	428	33	2970

7.2.4 Scenario 2 with all variations in the German model

Month	PV production per 1m ²	PV production per the whole area 330.42MWh	Energy demand for cooling	Electricity demand for cooling with compression cooling machine with annual COP of 3	Energy demand for heating	Electricity demand for heating with Ground source heat pump with annual COP of 3	Electricity demand for heating and cooling	In-house consumption of PV	Electricity from PV system feeding into the grid	Remaining electricity demand from the grid for heating and cooling
SUM(kWh)		50413	5270	1757	51946	17315	19072	6306	44107	12766
January		1148	0	0	10585	3528	3528	804	344	2724
February		2038	0	0	9293	3098	3098	950	1089	2148
March		3762	0	0	7090	2363	2363	888	2874	1475
April		5385	0	0	3206	1069	1069	494	4890	574
May		7577	267	89	1138	379	469	278	7299	190
June		6405	888	296	55	18	314	263	6141	51
July		7456	1914	638	0	0	638	521	6935	117
August		6751	2118	706	0	0	706	516	6236	190
September		4244	82	27	84	28	55	41	4204	15
October		3263	1	0	1901	634	634	203	3060	431
November		1365	0	0	8207	2736	2736	679	686	2056
December		1019	0	0	10386	3462	3462	668	351	2794

7.2.5 East and West windows with semi-transparent PV modules based on Scenario 2 in the Korean model

Month	PV production per 1m ²	PV production per the whole area 534.6m ²	Energy demand for cooling	Electricity demand for cooling with compression cooling machine with annual COP of 3	Energy demand for heating	Electricity demand for heating with Ground source heat pump with annual COP of 3	Electricity demand for heating and cooling	In-house consumption of PV	Electricity from PV system feeding into the grid	Remaining electricity demand from the grid for heating and cooling
SUM(kWh)	50.58	27038	51063	17021	109180	36393	53414	14113	12925	39301
January	2.61	1398	0	0	31766	10589	10589	1398	0	9191
February	3.09	1652	0	0	22956	7652	7652	1638	14	6014
March	4.91	2625	0	0	14270	4757	4757	1585	1040	3172
April	5.81	3105	0	0	2104	701	701	255	2850	447
May	6.47	3461	1834	611	0	0	611	401	3060	210
June	4.99	2668	7802	2601	0	0	2601	1331	1336	1270
July	4.42	2363	15152	5051	0	0	5051	1845	518	3205
August	4.66	2490	18892	6297	0	0	6297	2248	242	4049
September	4.11	2199	7158	2386	0	0	2386	1090	1110	1296
October	4.12	2200	224	75	210	70	145	76	2124	69
November	2.93	1567	0	0	12384	4128	4128	936	631	3192
December	2.45	1310	0	0	25492	8497	8497	1310	0	7187

7.2.6 South walls with opaque PV modules based on Scenario 2 in the Korean model

Month	PV production per 1m ²	PV production per the whole area 575.64m ²	Energy demand for cooling	Electricity demand for cooling with compression cooling machine with annual COP of 3	Energy demand for heating	Electricity demand for heating with Ground source heat pump with annual COP of 3	Electricity demand for heating and cooling	In-house consumption of PV	Electricity from PV system feeding into the grid	Remaining electricity demand from the grid for heating and cooling
SUM(kWh)	204.17	117527	65207	21736	97795	32598	54334	23671	93855	30663
January	17.37	10000	0	0	30234	10078	10078	3495	6505	6583
February	17.55	10103	0	0	21113	7038	7038	2603	7500	4435
March	20.09	11566	0	0	11386	3795	3795	1439	10127	2356
April	18.90	10882	29	10	789	263	273	107	10775	165
May	15.88	9144	5133	1711	0	0	1711	1214	7930	497
June	12.94	7448	10663	3554	0	0	3554	2157	5292	1398
July	12.23	7039	17720	5907	0	0	5907	3094	3945	2813
August	14.29	8227	21576	7192	0	0	7192	3564	4663	3628
September	16.12	9279	9360	3120	0	0	3120	1699	7580	1421
October	21.71	12494	726	242	19	6	248	177	12317	71
November	19.53	11241	0	0	10284	3428	3428	1241	10000	2187
December	17.55	10103	0	0	23970	7990	7990	2880	7223	5110

7.2.7 East and West roofs with opaque PV modules based on Scenario 2 in the Korean model

Month	PV production per 1m ²	PV production per the whole area 231.98m ²	Energy demand for cooling	Electricity demand for cooling with compression cooling machine with annual COP of 3	Energy demand for heating	Electricity demand for heating with Ground source heat pump with annual COP of 3	Electricity demand for heating and cooling	In-house consumption of PV	Electricity from PV system feeding into the grid	Remaining electricity demand from the grid for heating and cooling
SUM(kWh)	231.64	53736	65207	21736	97795	32598	54334	19103	34633	35231
January	10.18	2361	0	0	30234	10078	10078	2148	213	7930
February	12.95	3005	0	0	21113	7038	7038	2008	997	5030
March	21.14	4904	0	0	11386	3795	3795	1275	3628	2520
April	28.33	6572	29	10	789	263	273	102	6470	171
May	31.23	7244	5133	1711	0	0	1711	1157	6087	554
June	25.84	5994	10663	3554	0	0	3554	1975	4019	1580
July	22.12	5133	17720	5907	0	0	5907	2681	2452	3226
August	22.46	5211	21576	7192	0	0	7192	3201	2011	3991
September	18.96	4399	9360	3120	0	0	3120	1543	2856	1577
October	17.28	4009	726	242	19	6	248	171	3838	77
November	11.62	2696	0	0	10284	3428	3428	914	1782	2514
December	9.52	2208	0	0	23970	7990	7990	1929	279	6061

7.2.8 Scenario 2 with all variations in the Korean model

Month	PV production per 1m ²	PV production per the whole area 1342.22m ²	Energy demand for cooling	Electricity demand for cooling with compression cooling machine with annual COP of 3	Energy demand for heating	Electricity demand for heating with Ground source heat pump with annual COP of 3	Electricity demand for heating and cooling	In-house consumption of PV	Electricity from PV system feeding into the grid	Remaining electricity demand from the grid for heating and cooling
SUM(kWh)		198300	51063	17021	109180	36393	53414	24941	173359	28473
January		13758	0	0	31766	10589	10589	4093	9665	6496
February		14760	0	0	22956	7652	7652	3187	11573	4465
March		19094	0	0	14270	4757	4757	2109	16986	2648
April		20559	0	0	2104	701	701	302	20257	399
May		19849	1834	611	0	0	611	456	19393	155
June		16110	7802	2601	0	0	2601	1725	14385	876
July		14534	15152	5051	0	0	5051	3034	11500	2017
August		15929	18892	6297	0	0	6297	3598	12331	2699
September		15878	7158	2386	0	0	2386	1430	14448	956
October		18704	224	75	210	70	145	84	18620	61
November		15504	0	0	12384	4128	4128	1642	13861	2486
December		13622	0	0	25492	8497	8497	3281	10341	5216