



TECHNISCHE
UNIVERSITÄT
DRESDEN



FAKULTÄT ELEKTROTECHNIK
UND INFORMATIONSTECHNIK

Chair and Laboratory of Measurement and Sensor System Technique (MST) / Czarske Lab

Annual Report 2023



CZARSKE LAB



DRESDEN
concept



Table of Contents

Preamble	3
Staff	5
Teaching	10
Invited talks	12
General Congress ICO-25-OWLS-16	16
Research projects	18
Graduate theses	45
Publications and Talks	52
Activities	59
Partners (selection)	62

PREAMBLE

Dear friends and partners of the Chair MST / Czarske Lab,

The Chair of Measurement and Sensor Systems (MST) / Czarske Lab is celebrating its 19th anniversary. We look back on an eventful year. It is a great pleasure and honor for me to report on our activities this year. Several new projects were acquired. An international project is also underway. Of particular note is the commercial success of the laser profile sensor for speed and temperature measurement, developed by Lars Büttner et al. The transfer was carried out in collaboration with the company ILA R&D GmbH, Jülich. This innovation, which was successful on the market, was awarded the Berthold Leibinger Innovation Prize. The students and employees of the Czarske Lab were honored with over 10 prizes this year. In total, the MST has received more than 110 honors, prizes and awards, including the recent Berta Benz Prize worth 10,000 euros for Katrin Philip. It is pleasing that an ERC was received from the alumni (Andreas Fischer, Bremen).

In 2017, the general congress ICO-24 was opened in Tokyo by the Japanese Emperor and Dresden was chosen for the next world congress. After 3 years of intensive preparation with support of OPTICA, SPIE, IEEE, EOS, DGaO, ZEISS, TU Dresden, ICO, OWLS, and further partners the congress could not take place due to the covid-19 pandemic, unfortunately. It was postponed for one year and then postponed again after an intensive discussion in the general assembly of ICO about digital formats. 2022, the in-person world congress ICO-25-OWLS-16 was held with great success with unexpected high international presence and quality. Attendees from 55 countries from 5 A (Africa, America, Asia, Australia, Amazing Europe) and an extraordinary quality density with 3 Nobel laureates have thrilled us. We acknowledge all supporters and staff members, especially Nektarios Koukourakis and Lars Buettner. Furthermore, Michael Pfeffer and Wolfgang Osten are to be thanked for the commitment to the on-site organization and the scientific program, respectively. Information about the world congress ICO-25-OWLS-16-Dresden-Germany-5-9-September-2022 with the theme "Advancing Society with Light" can be found at the website <https://www.ico25.org>

The Czarske Lab has successfully acquired projects in new research topics such as optogenetics with human stem-cell-derived organoids. First we have starting with visions on optogenetics only, then a very successful project cooperation with the genetic labs at CRTD was running. This year high-quality papers were published, such as in Life Science Alliance, titled "Tracking connectivity maps in human stem cell-derived neuronal networks by holographic optogenetics". For multimode fiber transmission new approaches for physical layer security were demonstrated. The control of the scattering processes in fibers or tissues with modern wavefront shaping techniques opens up new directions of transfer to applications. Dr Nektarios Koukourakis and Dr Jiawei Sun have pioneered the cell tomography and recently the publication in the Nature family was achieved. Projects were acquired on quantum technology of the second generation too. Artificial Intelligence, Machine Learning and Deep Learning are playing a more and more important role. Deep neural networks can learn the light propagation through lensless fiber endoscopes towards a classification of human brain tumors. This new differentiation approaches of malignant and benign tumors using ultrathin endoscopes are promising for advanced medical diagnoses in real-time. Important funding from BMBF was achieved by projects such as ENOWA I, ENOWA II, KORONA, Quiet, 6GLife, GoBio.

We like to highlight the international network including: Liangcai Cao, Tsinghua University, China; Jakob Woisetschläger, TU Graz, Austria; Waclaw Urbanczyk, Kinga Żołąncz, Wrocław Univ. of Science and Technology; Jinping Qu, South China University of Technology; Adam Pierce, University of California Berkeley; Zeyu Gao, Ping Yang, Chinese Academy of Sciences, Chengdu; Danfeng Lu, Xi'an University of Technology, China, "adaptive optics", visiting researcher (2023-2024). Furthermore, cooperations are running together with Yale University, USA; Stanford University, USA;

Transcampus and Kings College London; University College London; CORE at Utsunomiya University, Japan; Eutopia, Brussels University; and the Stellenbosch and Wits SPIE Student Chapters.

In the faculty of electrical and computer engineering (EE) of the TU Dresden, the measurement systems technique plays a crucial role. Without measurements, the control of systems is not possible and measurement and sensor systems are an essential part of AMR (automation, measurement and control technique). The Czarske Lab is an integral part of the studies in electrical engineering, mechatronics, biomedical engineering, information system engineering and especially AMR. Starting with the 4th semester, basics in measurement data analysis as well as sensor technique are introduced. In the 5th semester, the approaches in digital measurement techniques, measurement system theory and advanced sensor techniques for biomedicine too are introduced. Further lectures are offered in the higher semesters for the specialization in computational metrology for technical processes and biomedicine.

Since 2019, the Czarske Lab offers a lecture on “Biomedical Systems and Optogenetics” (9th Semester), which is presented in English now. It should be integrated to moduls of the study of the cluster Physics of Life. E-learning plays an important role in modern lecturing, especially since the covid-19 pandemic. For the lecture Measurement Systems I, 4th Semester, we offer a digital bonus examination. In the lecture Measurement Systems II, 5th Semester, a Python programming task as bonus is scheduled online. In total, the Czarske Lab conducted more than 15,000 exams and over 200 defenses of Bachelor and Master Theses (“Studienarbeiten, Diplomarbeiten”). The extraordinary commitment of the staff members has to be appreciated. It is very gratifying that every course of the lecture program of Czarske Lab could be offered especially during covid-19 in a digital format. I acknowledge the great team work. An extraordinary research-oriented lecturing was established with the OPTICA-SPIE student chapter to foster students in optics and photonics. In the Czarske Lab we follow the idea of Humboldtian education ideally to combine research and studies. Students are actively involved in research by attending at conferences already in their undergraduate studies. Regular excursions to companies in the region, such as SICK Engineering GmbH, Ottendorf-Okrilla, are offered. Our employees and partners actively contribute every day towards scientific and transfer success. The computational adaptive metrology systems enable a multitude of demanding applications in biomedicine, fiber communication, and further areas. With the center BIOLAS we aim to transfer novel adaptive laser systems towards real-world application in biomedicine. In order to maintain our successful course, we are looking for committed physicists, engineers and other employees who will further advance the Czarske Lab with their great ideas. I would like to emphasize the great commitment of Dr Felix Schmider, David Weik, and Qian Zhang to the additional work for MST/Czarske Lab for the computer network, intranet, internet, PCs, GPU and the servers. Dennis Pohle carried out important work for industry partner Hereus.

I acknowledge the students and team members for the committed research and teaching and our partners for the efficient and effective cooperation.

Stay healthy, thank you and all the best

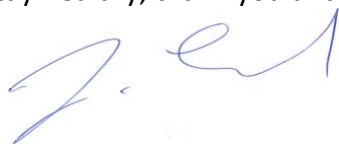

Prof Juergen Czarske

STAFF

No.	Name	Title	Position
1	Al-Khouri, Gabriel		Student Assistant
2	Bilsing, Clemens	Dipl.-Ing.	Research Assistant
3	Böhm, John		Student Assistant
4	Bürkle, Florian	Dr.-Ing.	Research Assistant
5	Büttner, Lars	Dr. rer. nat.	Postdoc, Senior Research Fellow; Head of Department „Laser Measurement Systems“
6	Czarske, Jürgen	Prof. Dr.-Ing. habil.	Full Professor, Head of MST Director of the Czarske Lab Director of BIOLAS Center
7	Dou, Zehua	M. Sc.	Research Assistant
8	Dremel, Jakob	Dipl.-Ing.	Research Assistant
9	Eberling, Kerstin		Team Assistant, part-time
10	Emmerich, Hannes	Dipl.-Ing.	Research Assistant
11	Geppert, Anna-Lena	Dipl.-Ing.	Research Assistant
12	Glosemeyer, Tom	Dipl.-Ing.	Research Assistant
13	Ortegón González, David Fernando	Dipl.-Ing.	Research Assistant
14	Guo, Ning		Research Assistant
15	Gürtler, Johannes	Dr.-Ing.	Postdoc / Research Assistant
16	Hafizi, Irdi		Student Assistant
17	Hartl, Georg	M. Sc.	Research Assistant
18	Jiang, Haowen	Dipl.-Ing.	Research Assistant
19	John, Cathleen		Senior Executive Team Assistant
20	Jose, Nidhin	B.Sc.	Student Assistant
21	Kirsch, Nele		Student Assistant
22	Koukourakis, Nektarios	Dr.-Ing.	Postdoc, Research Fellow, Head of Department “Bio-photonics and Laser Metrology”, CEO of BIOLAS center
23	Krause, David	Dipl.-Ing.	Research Assistant
24	Krenkel, Justus		Student Assistant
25	Kroll, Martin	Dr. M. Sc.	Research Assistant

26	Kuschmierz, Robert	Dr.-Ing.	Postdoc, Research Fellow, Head of Group “Laser Systems for Biomedicine”
27	Ließ, Konrad		Student Assistant
28	Lich, Julian	M. Sc.	Research Assistant
29	Nütznadel, Erik		Research Assistant
30	Pohle, Dennis	Dipl. -Ing.	Research Assistant
31	Rietmann, Piet		Student Assistant
32	Rothe, Stefan	Dr. -Ing.	Research Assistant
33	Scharf, Elias	Dipl.-Ing.	Research Assistant
34	Schmidt, Katharina	M. Sc.	Research Assistant
35	Schmieder, Felix	Dr.-Ing.	Research Assistant
36	Sun, Jiawei	Dr.-Ing.	Research Assistant
37	Tien, Hieu Bui		Student Assistant
38	Volkova, Veronika	B. Sc.	Research Assistant
39	Wang, Tijue	M. Sc.	Research Assistant
40	Weik, David	Dipl.-Ing.	Research Fellow, Head of Group “Ultrasound Imaging”
41	Zhang, Qian	Dipl.-Ing.	Research Assistant

External Ph.D. Student:

Meloni, Ilenia, M. Sc., Topic Optogenetics, Kurt-Schwabe-Institut Meinsberg e.V.

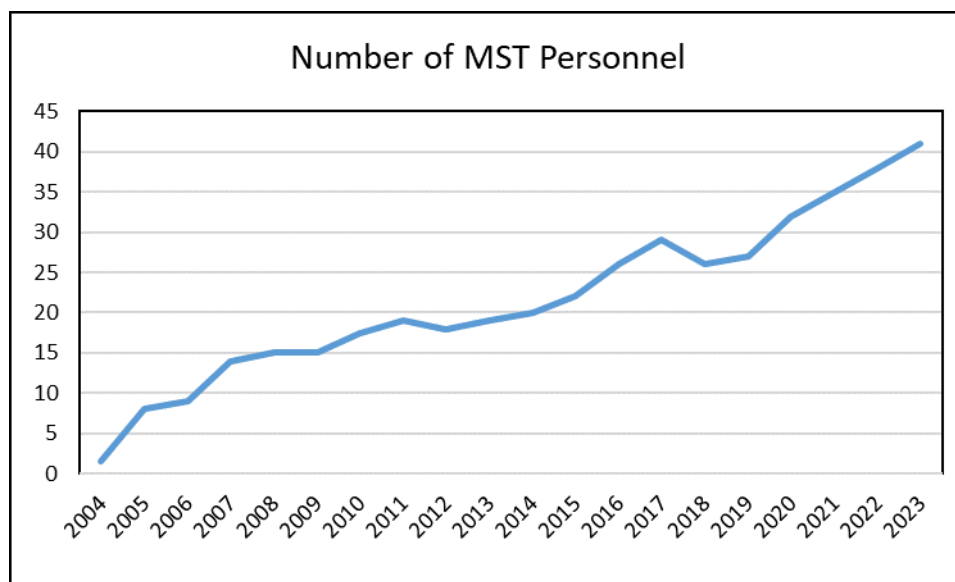

Number of staff members, excluding administration and technical members of the workshop etc.



The OPTICA-SPIE student chapter of TU Dresden is a group of undergraduate and graduate students in Dresden, Germany, with an interest in Optics and Photonics. Since September 2017, we belong to a worldwide network of student chapters supported by SPIE (The international society of optics and photonics, Washington, USA) and since 2022 additionally to the OPTICA chapters. We maintain contacts to other international student chapters in South Africa, Poland, Czech Republic, UK and Germany. Several pre-diploma students are members of the OPTICA-SPIE chapter. Our objective is to establish and intensify the contact between students and faculty at different optics-related groups and institutes in the Dresden area. Therefore, we host regular public lecture series with speakers from research groups and institutes relevant to optics and photonics. Besides that, we are organizing excursions to nearby companies. The highlights of this year have been the Zemax workshops of Prof. Gross, the excursion to HoloEye GmbH in Berlin as well as the numerous talks that were given by external speakers.

The student chapter of TU Dresden is a unique opportunity for students to build knowledge and their own network in optics and photonics. We are looking forward to further planned activities and new chapter members in 2024.



The OPTICA-SPIE Student Chapter of TU Dresden

Great support of Dr Olaf Bergmann (CRTD, Biopolis) with lectures for the S1 lab and genetic experiments:

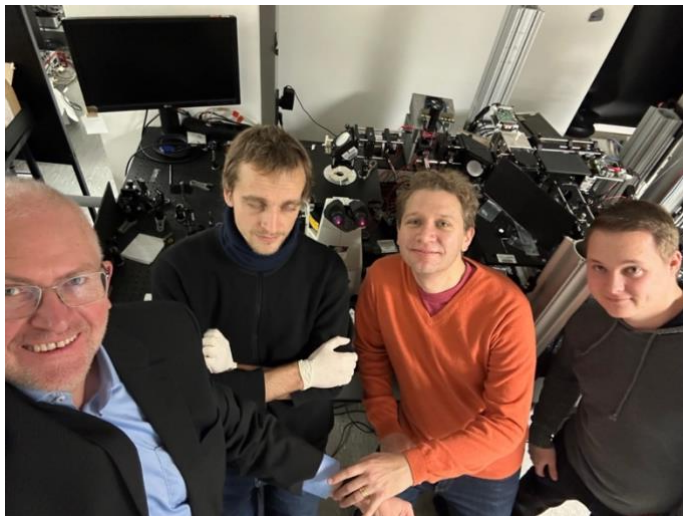

From left: Juergen Czarske, Felix Schmieder, Olaf Bergmann, Georg Hartl (Photos by MST)

Lecture of SPIE Student Chapter by Prof Herbert Gross, Jena, Photo by MST:



Visits, Meetings and Cooperation Partners



In San Francisco, from left, Zeev Zalevsky, Demetri Psaltis, Pietro Ferraro, Christophe Moser, Juergen Czarske, Paul Park, Daniel Brunner, Aydogan Ozcan

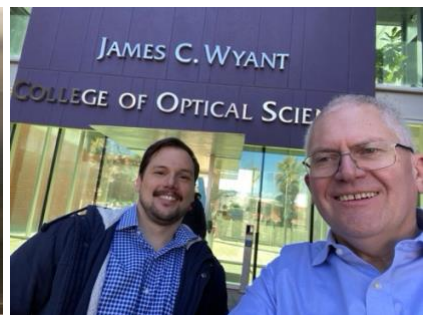

In San Francisco, with Wilhelm Kaenders (Toptica). In Arizona, with Florian Willomitzer



In Munich, left Augustiner Stammhaus and right Deutsches Museum, with Bernard Kress, Google

TEACHING

		WS 22/23	SS 2023
Grundzüge des Messens 4. Sem.	V: Prof. Czarske Ü: Ning Guo, Dou Zehua	13	87
Mess- und Sensortechnik 5. Sem.	V: Prof. Czarske, V: Dipl.-Ing. Weik Ü: Dipl.-Ing. Gürtler, Dipl.-Ing. Emmerich	123	9
Praktikum Mess- und Sensortechnik 5.+6. Sem.	P: Julian Lich, Tom Glosemeyer, et al. Prof. Czarske	84	18
Messsystemtechnik 6. Sem.	V: Prof. Czarske Ü: Katharina Schmidt Dipl.-Phys. Schmieder	-	21
Lasermesstechnik 8. Sem.	V: Prof. Czarske Ü: Dr. Büttner	-	21
Mechatronische Lasersensoren 8. Sem.	V: Dr. Büttner, Prof. Czarske	-	21
Lasermesssysteme für die Fluidtechnik 9. Sem.	V: Dr. Büttner, Prof. Czarske	5	-
Digitale Holographie und Bildverarbeitung 9. Sem.	V: Dr. Koukourakis, Prof. Czarske	9	-
Biomedizinische Laser-Systemtechnik und Optogenetik	V: Dr. Kuszmierz, Prof. Czarske	12	-
Praktikum Lasersensorik	V: Prof. Czarske P: Dipl.-Ing E. Scharf	-	13
Hauptseminar AMR	Dipl.-Ing E. Scharf Dr. Kuszmierz, Prof. Czarske	9	-
Sub-Total:		255	192
Total:		447	

Total number in 19 years: 18153

Modules at MST:

Automatisierungs- und Messtechnik (3/2/0) (ET, MT)

Hauptseminar AMR (0/2/0) (ET)

Mess- und Sensortechnik (2/1/1) (ET, MT)

Prozessleittechnik (6/2/2) (ET)

Lasersensorik (4/1/1) (ET)

Oberseminar Messsystemtechnik (0/2/0) (ET, MT, Phy, NES, POL, CMS)

Photonische Messsystemtechnik (4/2/0) (ET)

Sensoren u. Messsysteme-Grundlagen (5/2/0) (MT)

Sensoren u. Messsysteme-Vertiefung (3/0/2)

Optische Prozessmesstechnik (4/2/0) (RES)

Non-Physics Supplement (7/2/0) (Phy)

Computational Laser Metrology – Fundamentals (1/3/1) (INF)

Computational Laser Metrology – Advances (6/4/0) (INF)

ET - Electrical engineering (Diplom/ Master)

MT – Mechatronics

RES - Regenerative Energiesysteme

Phy – Physics

INF – Informatics

NES – Nanoelectronic Systems

POL – Physics of Life

CMS - Computational Modeling and Simulation

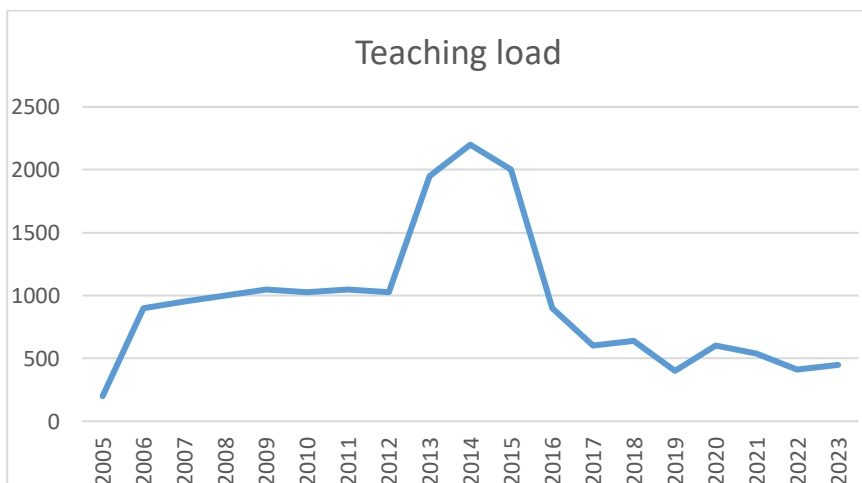

INVITED TALKS

Date	Guest Speaker	Topic
01 Nov. 2023	Dr. Shwetadwip Chowdhury, Univ Texas, USA	Multidimensional optical imaging through scattering (digital presentation)
27 Okt. 2023	Dr. Maxim Cherkashin Ruhr-Universität Bochum	Refractive acoustooptics and light waveguiding with transient ultrasound
03 July 2023	Adam Pierce University of California at Berkeley	All Digital Microwave Impedance Microscopy & Optogenetic Control of Contraction in Cardiomyocyte network Multispectral Lensless Endoscopy
30 June 2023	Prof. Liangcai Cao Tsinghua University	High bandwidth holographic imaging
23 June 2023	Peter de Groot Zygo Corporation	Adventures in white-light interferometry
19 June 2023	Hannes Emmerich & Dr. Eric Starke Sick Engineering	Ultrasonic transducers in multiphase processes and flow measurements in challenging applications
19 June 2023	Prof. Heidi Ottevaere Vrije University Brussels	Biophotonics at Brussels Photonics and its Applications in Life Sciences and Medicine
08 May 2023	Dr Wenfeng Xia King's College London	Packing Sound and Light into Smart Needles for Surgical Guidance

Awards, Prizes, Honors and Elections

Jie Zhang	Theodore Maiman Scholarship of Scientific Society for Laser Technology , WLT, or her student theses "Real-time quantitative phase imaging through an ultra-thin lensless microendoscope" (2 000 Euro), Hannover, 2023
David Krause	DGaO Young talent award (550 €) for his master theses "Measurement of the transmission matrix of multimode fibers using neural networks and modern digital holography", anniversary 100 years DGaO Berlin
Jürgen Czarske	Honoary Speaker Award, 23 rd "StarRiver" Talk, AI Lab, Shanghai, Nov 2023
Jie Zhang	Theodore Maiman Scholarship for her student theses "Real-time quantitative phase imaging through an ultra-thin lensless microendoscope"
Jürgen Czarske	Award Certificate in appreciation for his timely, careful review and checking out many important details for the manuscript of <i>Light: Science & Applications</i> in May 2023. (Springer Nature, CIOMP, COS)
Jürgen Czarske	Elected in the Editorial Board of High-Impact Journal <i>Light: Science & Applications</i> of Nature, selected August 2023
Jürgen Czarske	Elected as Distinguished Lecturer of IEEE Photonics Society 2024, awarded November 2023
Jiawei Sun	Prize of Dr. Ing Siegfried Werth Foundation for an outstanding PhD Thesis on Dimentional Metrology, Gießen, Mai 2023  Dr Schniewind, Dr Sun, Prof Czarske, Prof Bock (from left)/ Dr Schniewind, Dr Sun, Prof Czarske (from left)
Nektarios Koukourakis	Certification: Sincere Appreciation for research, innovation and publications by BIOLAS, November 2023
Jiawei Sun	Certification: Sincere Appreciation for research, innovation and publications by BIOLAS, November 2023
Jiawei Sun	Jiawei Sun, Jiachen Wu, Song Wu, Ruchi Goswami, Salvatore Girardo, Liangcai Cao, Jochen Guck, Nektarios Koukourakis, Juergen Czarske Certificate of recognition for Quantitative phase imaging through an ultra-thin lensless fiber endoscope as one of the top downloaded papers of <i>Light: Science & Applications</i> , 03/2023.
Jiawei Sun	Barkhausen Prize 2023 for the best dissertation in electrical engineering - the prize is sponsored by the Carl Friedrich von Siemens Foundation and is endowed with 2,500 euros. The prize

	was awarded during this year's Faculty Day on November 3, 2023. Faculty of Electrical Engineering and Information Technology TU Dresden
Katharina Schmidt	sponsorship award of the association "Freunde und Förderer der Fakultät Elektrotechnik und Informationstechnik der TU Dresden e.V." (Friends and Sponsors of the Faculty of Electrical Engineering and Information Technology of the TU Dresden). With this award, the association honors scientific staff members of the faculty who have distinguished themselves through special commitment. The prize is endowed with 500 € and was awarded during this year's Faculty Day on November 3, 2023.
Jürgen Czarske	Certificate from Tsinghua University, Appreciation for outstanding lecture at the Department of Precision Instrument, Tsinghua University, China, 8/ 2023
Jürgen Czarske	Prize of Chinese Academy of Science: Qinghe Seminar 70th, Shanghai 08/2023  <p>Photos at the Shanghai Institute of Optics and Finemechanics (right photo, fltr, Dr Wu, Dr Sun, Prof Czarske, Prof Situ, et al.)</p>
Stefan Rothe	Prize for Measurement and Sensor Technology of the Gisela and Erwin Sick Foundation, dissertation: "Exploiting the interference of multimode fibers to achieve information security on the physical layer", TU Dresden, 04/2023
Jie Zhang	Prize for Measurement and Sensor Technology of the Gisela and Erwin Sick Foundation, student thesis: "Quantitative phase imaging in real time by an ultrathin lensless microendoscope", TU Dresden, 04/2023
David Krause	Young Scientist Award of the Gisela and Erwin Sick Foundation, diploma thesis: "Measurement of the transmission matrix of multimode fibers using neural networks and modern digital holography", TU Dresden, 18.04.2023  <p>Eric Starke, David Krause, Prof. Czarske © MST</p>
Jakob Dremel	Best Student Award of TU Dresden, presented by Prof. Ursula Staudinger, Rector of TU Dresden, 12/2022, awarded 2023
Tom Glosemeyer	SPIE Scholarship to cover traveling expenses for San Francisco – SPIE: The international society for optics and photonics, USA, 12/2022, conference Jan-2023



Total number of elections, honors, prizes and awards: over 100

GENERAL CONGRESS ICO-25-OWLS-16

Photo gallery (All Photos by MST)-Looking back to the World Congress



Left: Opening of the General Congress ICO-25-OWLS-16 /
Right: First Mayor Sittel and General Chair Czarske in the City Hall (from right)



Photo of the participants of the General Congress on Monday morning



Nobel Laureate Gérard Mourou and General Chair Juergen Czarske (from left)



Nobel Laureate Stefan Hell and General Chair Juergen Czarske (from left)



Nobel Laureate Reinhard Genzel and General Chair Juergen Czarske (from right)



Welcome Reception and Organ Concert in the Frauenkirche



General Assembly of ICO, group photo in front of the Venue

RESEARCH PROJECTS

BIOLAS Focusing light through scattering tissue

Staff: N. Koukourakis, J. Czarske

Aim: Targeted light-delivery through scattering tissue is strongly limited by light scrambling. However, the technological improvement in hardware, computational power and methodology in recent years made it possible to control light inside or behind scattering media, by shaping the wavefront using a spatial light modulator before the light enters the scattering media. The main hurdle is to determine an adequate mask that allows pre-scrambling the light, so that the desired light pattern is delivered to the region of interest after scrambling. These are for example iterative optimization of the wave front, measurement of the transmission matrix, and digital optical phase conjugation (DOPC). DOPC has the advantage that it does not require time-consuming iterations or time-consuming calibration measurements, but instead enables direct shaping with a single measurement. Commonly guide stars are used to probe the light scrambling. The phase of the guide star light is recorded by quantitative phase measurements, e.g. performed by digital holography, and a phase mask of the phase conjugate is displayed on the spatial light modulator. This approach enables to time reverse the scrambling effects and to recreate the guide star. We applied DOPC for example, to focus light through 400 μm thick part of a mouse skull. While without DOPC strong scattering is observable (Figure, left), DOPC allows focusing through mouse skull with high quality (Figure, right). Such an approach is important for the optogenetic stimulation.

Partner: Max Planck Institute of Molecular Cell Biology and Genetics, Dr. M. Kreysing

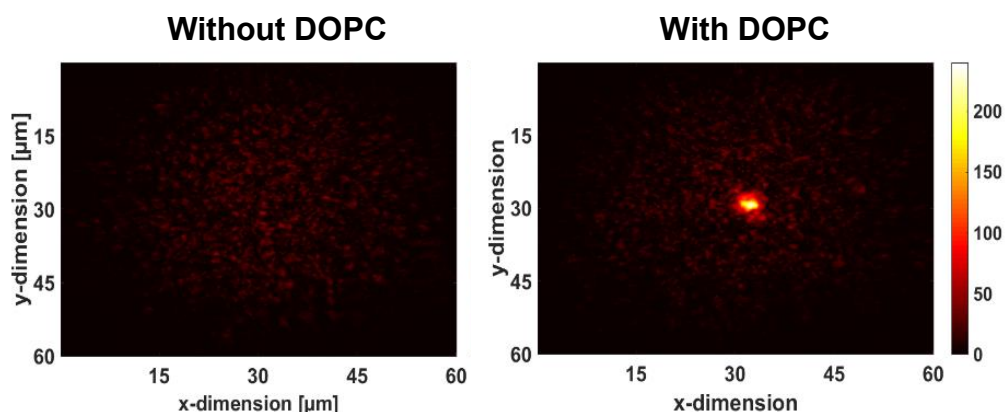

Focusing through mouse skull, (left) without digital optical phase conjugation and (right) with digital optical phase conjugation.

N. Koukourakis, M. Kreysing, J. Czarske, "Wave front shaping method to focus through mouse skull", OSA Imaging and Applied Optics, Contribution OW2J.3, 25.–28.6.18, Orlando/USA

N. Koukourakis; M. Kreysing; J. Czarske, „Focusing Through Mouse Skull Using Wave front Shaping”, OSA, Biophotonics Congress: Biomedical Optics, 03.-06.04.2018, Hollywood, Florida, USA

Azaam Aziz, Stefano Pane, Veronica Iacovacci, Nektarios Koukourakis, Jürgen Czarske, Arianna Men-ciassi, Mariana Medina-Sánchez, and Oliver G. Schmidt, „Medical Imaging of Microrobots: Towards In Vivo Applications“; ACS Nano, 09/2020; DOI: 10.1021/acsnano.0c05530

Kayvan Forouhesh Tehrani; Nektarios Koukourakis; Jürgen Czarske; Luke J Mortensen, “In situ measurement of the isoplanatic patch for imaging through intact bone”, Journal of Biophotonics; 08/2020

BIOLAS Volumetric hybrid illumination microscopy

Staff: N. Koukourakis, K. Schmidt, J. Czarske

Aim: Wide field microscopy is well established in biological and medical applications. However, its reduced depth sectioning capability leads to background signals originating outside the depth of interest that degrade the contrast and limit the usability. To solve this limitation, a variety of microscopic techniques offering adequate depth sectioning have been introduced, the most prominent one being confocal microscopy. However, although confocal microscopy is advantageous, it is a pointwise technique and thus requires scanning in three dimensions to obtain 3D information.

Hybrid illumination microscopy enables to record optically sectioned wide field images by analyzing the spatial frequency content of the recorded image. As the maximum spatial frequency bandwidth is transported through the system for in-focus sample parts, high-spatial frequencies that inherently occur from the specimen, already lead to an optical sectioning. To get access to the low spatial frequency part of the focal region, a speckled illumination can be used, to artificially introduce high spatial frequencies. Thus, the combination of an uniform and a non-uniform illumination bears the potential to record optically sectioned images, with a strongly reduced scanning requirement. Just one axial scan is required. Using adaptive lenses allows to circumvent any mechanical scanning and to implement fast axial scanning without moving parts enabling rapid volumetric recordings. We use this technique to analyze fluorescence of transgene zebrafish larvae

Partner: Helmholtz Zentrum für Umweltforschung, Leipzig, Dr. Stefan Scholz

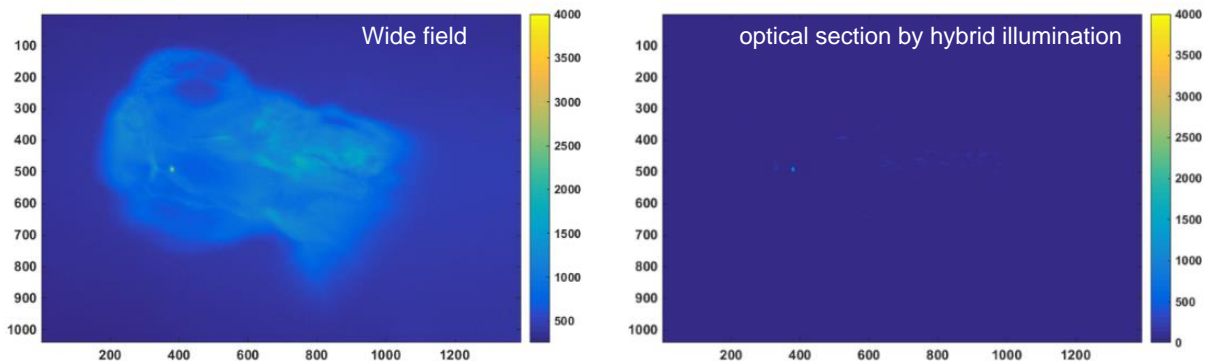

Left: Wide field fluorescence measurement of zebrafish larvae. Right: After spatial frequency analysis, the strong auto fluorescent background is removed.

N. Koukourakis, K. Philipp, M. Stürmer, F. Lemke, M. Wapler, U. Wallrabe, J. Czarske, "Adaptive lenses for axial scanning in HiLo microscopy", Optics in the Life Sciences Congress, OSA, 2-Page-Paper: BoTu1A.2, San Diego, CA, USA, 02.04.-05.04 (2017).

J. W. Czarske, K. Philipp, N. Koukourakis, „Structured illumination 3D microscopy using adaptive lenses and multimode fibers“, SPIE Digital Optical Technologies, Proceedings pp. [10335-44], Munich, Germany, 26.06. – 28.06.2017 (2017).

K. Philipp, A. Smolarski, N. Koukourakis, A. Fischer, M. Stürmer, U. Wallrabe, and J. W. Czarske, „Volumetric HiLo microscopy employing an electrically tunable lens,“ Opt. Express 24, No 13, 15029 (2016).

DFG Investigations on Brillouin elastography using a pulsed laser for biomedical applications

Staff: D. Krause, L. Liebig, N. Koukourakis, J. Czarske

Aim: The measurement of the elasticity of cells and tissues plays a major role in the investigation of pathological processes. Since the first report on non-contact, three-dimensional in-situ measurements of the elasticity of biological tissue using the spontaneous scattering between light and sound waves, great attention has been paid to Brillouin microscopy. Spontaneous Brillouin scattering is used, which allows locally high-resolution measurements but requires long integration times for each measuring point. The related technique of Impulsive Stimulated Brillouin Spectroscopy (ISBS) allows the measurement of the same tissue properties with a significantly increased time resolution. Imaging in real-time video resolution is therefore conceivable.

With ISBS, a standing acoustic wave is excited by a pulse laser in the measuring volume. The superposition of the pulse laser, which is divided into two beams, produces an intensity-striped pattern, which generates a force effect via electrostriction and thus the standing acoustic wave. By this standing wave, a second continuous wave laser is reflected and evaluated on a detector. The reflected beam is modulated according to the frequency of the standing wave. The strip spacing d given by the geometry, the frequency of the intensity of the reflected beam f and the speed of sound in the material v are related as follows: $v = 0.5 f d$.

Thus, the measured frequency can be used to determine the speed of sound and therefore the modulus of elasticity of the material. For initial measurements and the characterization of such a measuring system, measurements on reference liquids such as methanol, ethanol and water were successfully carried out. Measurements on biological reference samples, e.g. hydrogels were also accomplished. Brillouin-microscopy based on impulsive stimulation is particularly promising for scanning imaging but also high-speed measurements such as in the field of cytometry.

Period: 05/2019 – 04/2024

Partner: BIOTEC, Dresden, Prof. Jochen Guck

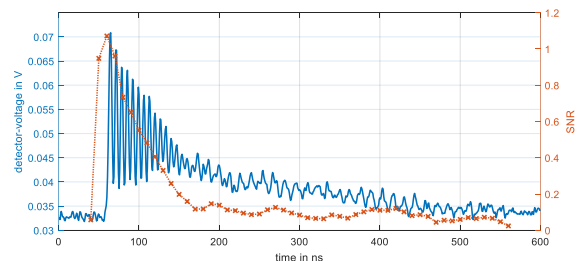
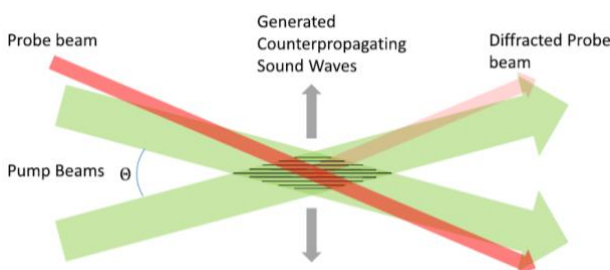

Left: Geometry for stimulated Brillouin. Right: Measurement at Methanol.

Giuseppe Antonacci, Timon Beck, Alberto Bilenca, Jürgen Czarske, Kareem Elsayad, Jochen Guck, Kyoohyun Kim, Benedikt Krug, Francesca Palombo, Robert Prevedel, Giuliano Scarcelli, "Recent progress and current opinions in Brillouin Microscopy for life science Applications", *Biophysical Reviews*, 2020

Impulsive stimulated Brillouin microscopy for non-contact, fast mechanical investigations of hydrogels, B Krug, N Koukourakis, JW Czarske - *Optics express*, 2019 - osapublishing.org

B Krug, N Koukourakis, J Guck, J Czarske, „Nonlinear microscopy using impulsive stimulated Brillouin scattering for high-speed elastography,” *Optics Express* **30** (4), 4748-4758 (2022).

China Quantitative phase imaging for confocal adaptive lens microscopy (CAL)

Staff: W. Wang, N. Koukourakis, J. Czarske

Aim: Quantitative phase imaging (QPI) has become a very important tool in metrology and biomedical applications. Commonly digital holography is applied for QPI. However, as it is an interferometric technique it requires coherent illumination, an additional reference beam and the recordable spatial frequencies are strongly limited by the pixel size of the camera. Shack-Hartmann sensor (SHH) is a non-interferometric alternative, but it suffers of limited resolution and allows recording only wave front tilts of small degree.

We apply the partitioned aperture wave front (PAW) sensing technique to combine the advantages of both approaches, having a technique that records the phase at high spatial resolution, at high wave front tilts non-interferometrically. PAW uses an array of four off-axis lenses, which divides a beam of light into four separated intensity images on the camera. Then, two-phase gradients can be obtained from the four intensity images by the PAW algorithm. Finally, the quantitative phase can be calculated by integrating the phase gradients and inverse Fourier transform.

We use PAW to measure the phase of light transmitting through an adaptive lens with high speed and high resolution. Driving complex adaptive lenses is often a difficult task. PAW is perfectly suited to characterize the lens behavior in a closed feedback loop.

Period: 04/2019 – 03/2023

Partner: University of Freiburg, Prof. Ulrike Wallrabe

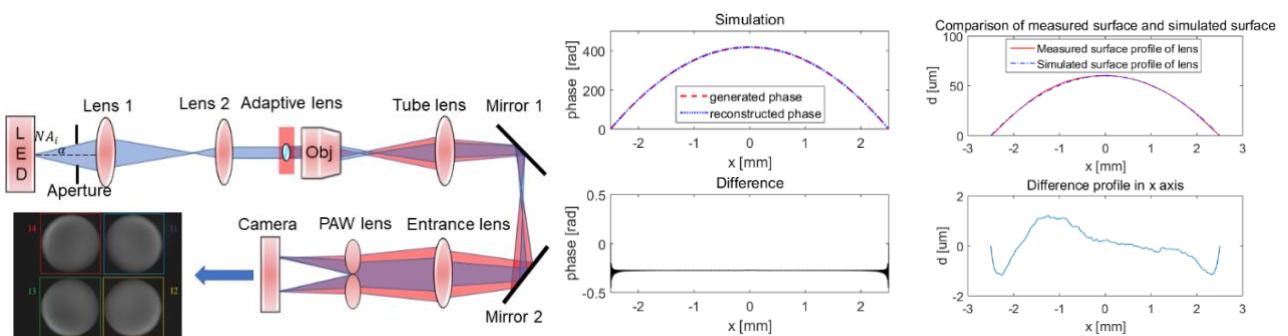

PAW imaging device in a Köhler illumination (left), the reconstructed phase shift induced by a simulated lens (middle) and the reconstructed phase shift of a fix lens in experiment (right).

W. Wang, K. Philipp, N. Koukourakis and J.W. Czarske, "Characterization of Adaptive Lenses using Partitioned Aperture Wavefront Imaging", EOSAM 2018, TOM 6 S04, (2018)

W. Wang, K. Philipp, J. Czarske, N. Koukourakis, "Real-time monitoring of adaptive lenses with high tuning range and multiple degrees of freedom", Optics Letters 45(2), 272-275, 2020

Lemke, Florian; Weber, Pascal; Philipp, Katrin; Czarske, Juergen; Koukourakis, Nektarios; Wallrabe, Ulrike; Wapler, Matthias, "Piezo-actuated adaptive prisms for continuously adjustable bi-axial scanning", Smart Materials and Structures, 2020

DFG Aberration correction for real-time measurements in adaptive confocal microscope

Staff: K. Schmidt, N. Koukourakis, J. Czarske

Aim: Microscopic techniques with high spatial and temporal resolution are required for measuring biological cells and tissues. Confocal microscopy is an established technique, which is based on a pinhole detection that introduces optical sectioning abilities. The usage of microscope objectives with high numerical aperture allows achieving high spatial resolution, but simultaneously increases the impact of systematic aberrations. These aberrations add to sample induced aberrations and limit the achievable resolution of a confocal microscope. Aberrations can be addressed by using adaptive optical elements. Furthermore, adaptive elements allow for fast scanning. In the preparatory work we successfully verified, that two adaptive lenses, one in the illumination and the second in the detection path, allow for the first time, to create axial scans with homogeneous axial resolution over the whole depth-range. The aim of the project is to create a fully-adaptive confocal microscope, which enables both fast scanning and high spatial resolution due to aberration correction. For this purpose, novel adaptive lenses with integrated aberration correction are developed and used to create the axial scanning. These lenses enable to compensate for both symmetric (spherical, defocus) und asymmetric (astigmatism, coma)-aberrations our confocal microscope. Furthermore, adaptive achromatic lenses for the correction of chromatic aberrations are developed. For lateral scanning adaptive prisms are used, which enable fast lateral scans with less aberrations and compact setup. Using the novel adaptive devices opens up the possibility to miniaturize the confocal setup and to create a compact microscope. As a first test paradigm, the new confocal microscope is used to identify thyroid gland disruptors in Zebrafish embryos.

Period: 10/2019 – 09/2025

Partner: Universität Freiburg, Prof. Wallrabe; UFZ Leipzig, Dr. Stefan Scholz

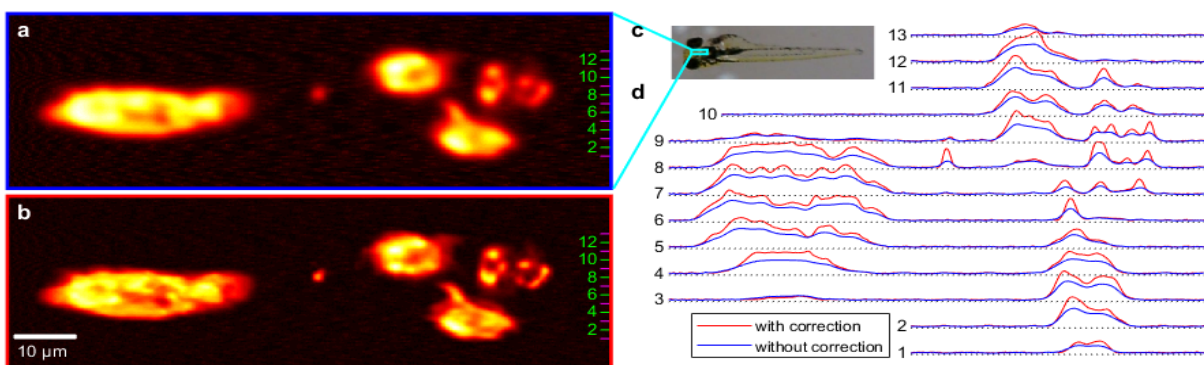

Fluoreszenzaufnahmen der Schilddrüse von transgenen Zebrafischembryonen ohne (a) und mit (b) Korrektur sphärischer Aberrationen. Aufnahme des gesamten Embryos, Dimensionen sind ca (1.5x5) mm² (c). Intensitätsprofile entlang spezifischer Zeilen (d). Die Aufnahmen erfolgten 110 Stunden nach der Befruchtung.

K. Philipp, A. Smolarski, N. Koukourakis, A. Fischer, M. Stürmer, U. Wallrabe, J. Czarske "Volumetric HiLo microscopy employing an electrically tunable lens", *Opt. Express* 24(13), 15029-15041 (2016).

W. Wang, F. Lemke, M. Wapler, U. Wallrabe, J. Czarske, "3D-scanning microscopy with adaptive lenses and prisms for zebrafish studies", *SPIE Journal of Optical Microsystems* (invited by Hans Zappe), 2021

K. Schmidt, N. Koukourakis, J.W. Czarske, "Assignment of Focus Position with Convolutional Neural Networks in Adaptive Lens Based Axial Scanning for Confocal Microscopy", *Appl. Sci. Vol* (12), 661 (2022)

DFG Tomographic refractive index measurement using Adaptive fiber-optical cell ROTation (TAROT)

Staff: J. Sun, N. Koukourakis, J. Czarske

Aim: The three-dimensional refractive index (RI) distribution of biological cells contains rich information on the metabolism, health and on intracellular structure. An important biophysical parameter that can be accessed without invasive cell staining by quantitative phase imaging (QPI). As QPI techniques are sensitive to integral path-length information the reconstruction of the three dimensional refractive index requires a multitude of projections under varying angles to enable 3D reconstruction using tomographic approaches. Changing the illumination angle via rotation of the specimen bears maximum spatial frequency coverage and is therefore advantageous compared to variation of the illumination angle. In this project, we aim to realize a versatile adaptive optical platform based on a novel dual-beam trap that enables for the first-time targeted cell-rotation about arbitrary axes in all spatial dimensions. The unique feature of our dual-beam trap is that light-delivery is accomplished by multi-core fibers (MCF) as key components of the system. Using an in-situ calibration by digital optical phase conjugation allows tailoring any desired light field distribution. To rotate the cells about the optical axis at least one beam has to have an asymmetric intensity profile to break the trap symmetry. Adaptively rotating this intensity profile results in a cell-rotation. The full light-field control further enables to induce additional targeted rotation by misaligning the traps or by illuminating with tailored intensity-gradients, enabling rotation in three dimensions. Quantitative phase imaging with full cell-rotation about two perpendicular axes will be realizable for the first time with fiber-based endoscopes.

Partner: Max Planck Institute for the Science of Light, Prof. Jochen Guck

Period: 11/2018 – 02/2024

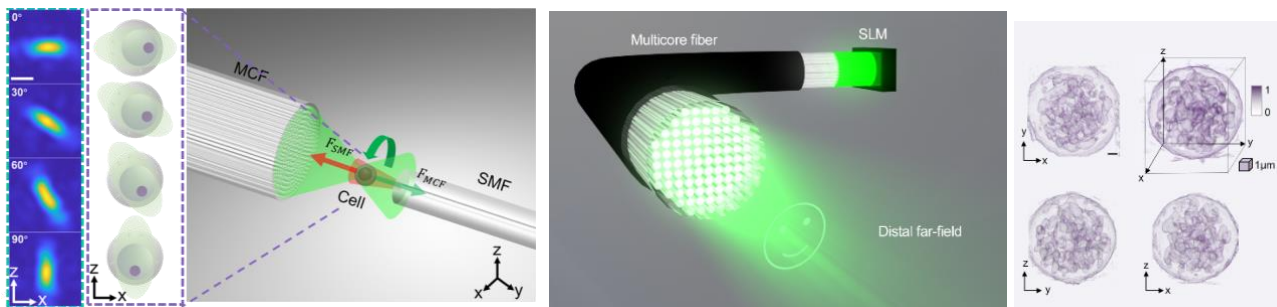

J. Sun, J. Wu, S. Wu, L. Cao, R. Goswami, S. Girardo, J. Guck, N. Koukourakis, J. Czarske, "Quantitative phase imaging through an ultra-thin lensless fiber endoscope," *Light Science & Applications*, 2022
J. Sun, J. Wu, N. Koukourakis, L. Cao, R. Kuschmierz and J. Czarske, "Real-time complex light field generation through a multi-core fiber with deep learning," *Scientific Reports*, 2022
J. Sun, N. Koukourakis, J. Guck and J. W. Czarske, "Rapid computational cell-rotation around arbitrary axes in 3D with multi-core fiber," *Biomedical Optics Express*, 2021
J. Sun, N. Koukourakis and J. W. Czarske, "Complex wavefront shaping through a multi-core fiber," *Applied Sciences*, 2021

DFG Physical Layer Security of Multimode Optical Fiber Transmission Systems

Staff: S. Rothe, D. Pohle, J. Czarske

Aim: Optical networks are the backbone of our information and communication society. The data traffic includes not only user data but also mission critical communication services, which are sensitive to eavesdropping and jamming attacks. This project studies the fundamental limits of physical layer security for data transmission through optical multimode fibers (MMF). In contrast to cryptographic security whose security is derived from the computational complexity of a cryptographic algorithm, in our project we are looking at the information theoretic security of the system, which guarantees secrecy regardless of the computation power available at the eavesdropper. Hence, this project concentrates on the fundamental limits of the security rate of MMFs between two legitimate nodes.

Experiments will be conducted at the Chair of Measurement and Sensor System Technique (MST) to determine the relationship between input and output modes of the MMF, i.e. the transmission matrix, to obtain reliable channel information, which will help the Communications Theory Chair (TNT) setting up and optimizing channel models, with the aim to maximize the confidentiality of communication and prohibit that the eavesdropper gains any valuable knowledge of the transmitted data. To prohibit that the eavesdropper gains any information of the channels during calibration, a public key method will be initially used. Finally, a demonstration of the feasibility of physical layer security using MIMO-SDM will be conducted.

Period: 09/2018 – 08/2024

Partner: Technische Universität Braunschweig, Institute for Communications Technology (IfN), Prof. E. Jorswieck, M. Sc. A. Lonnstrom/ M. Sc. Karl-Ludwig Besser

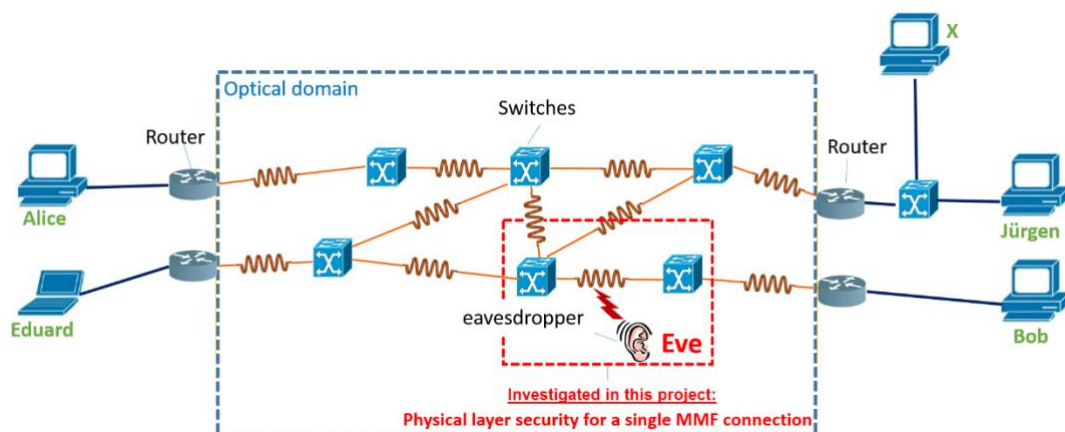

Optical network. In this project together with our partner, the physical layer security for a single MMF connection between two network nodes is investigated.

S. Rothe, N. Koukourakis, H. Radner, A. Lonnstrom, E. Jorswieck, J. Czarske, "Physical Layer Security in Multimode Fiber Optical Networks." Scientific Reports, 2020

S. Rothe, Q. Zhang, N. Koukourakis, J. Czarske, "Intensity-only Mode Decomposition on Multimode Fibers using a Densely Connected Convolutional Network", Journal of Lightwave Technology, DOI: 10.1109/JLT.2020.3041374 (2021).

S. Rothe, P. Daferner, S. Heide, D. Krause, F. Schmieder, N. Koukourakis, J. Czarske, "Benchmarking analysis of computer generated holograms for complex wavefront shaping using pixelated phase modulators." OPTICA Optics Express 29(23), 37602-37616 (2021)

BMBF 6G Life Hub

Staff: Q. Zhang, D. Pohle, S. Rothe, J. Czarske

Aim: Digitalization, or digital transformation, is one of the next great challenges facing humanity after the Neolithic and Industrial Revolutions. The future standard of mobile communications 6G will play a central role in this revolution. With 5G, the gateway to digitization in industry has been thrown wide open. While its predecessors 2G, 3G and 4G exclusively covered the consumer sector, 5G also supports the control of machines. 5G makes the Internet of Things possible in real time. However, a major drawback with 5G communication networks is the limited use of novel technologies. The Project, 6G-life, will drive cutting-edge research for 6G communication networks with a focus on human-machine collaboration. 6G-life provides new approaches for sustainability, security, resilience and latency. The research hub 6G-life is spanned by the TU Dresden (TUD) and TU Munich (TUM). The Chair of Measurement and Sensor System Technique (MST) is working on optical communication. MST will concentrate on Physical Layer Security (PLS) with optical MIMO systems, especially few-mode and multimode fiber using advanced deep neural networks such as the MTNet. Instead of increasing the security via mathematical approaches, the laws of physics can be used, as single photons cannot be measured without destruction. However, transmission over the spatial domain of multi-mode optical fibers requires further research. Using single-photon sources (e.g. Q-Dots), the goal is to make a sustainable 6G contribution to quantum communications. The vision is to bring modern computer-based aberration correction methods of optics and photonics into the 6G quantum testbed.

Period: 09/2021 – 09/2025

Partner: TU Munich, Institute for Communications Engineering
Prof. Gerhard Kramer, Prof. Dr.-Ing. Norbert Hanik, Dr. Carmen Mas Machuca
TU Dresden, Chair of radio frequency and photonics engineering
Prof. Dirk Plettemeier, Prof. Kambiz Jamshidi

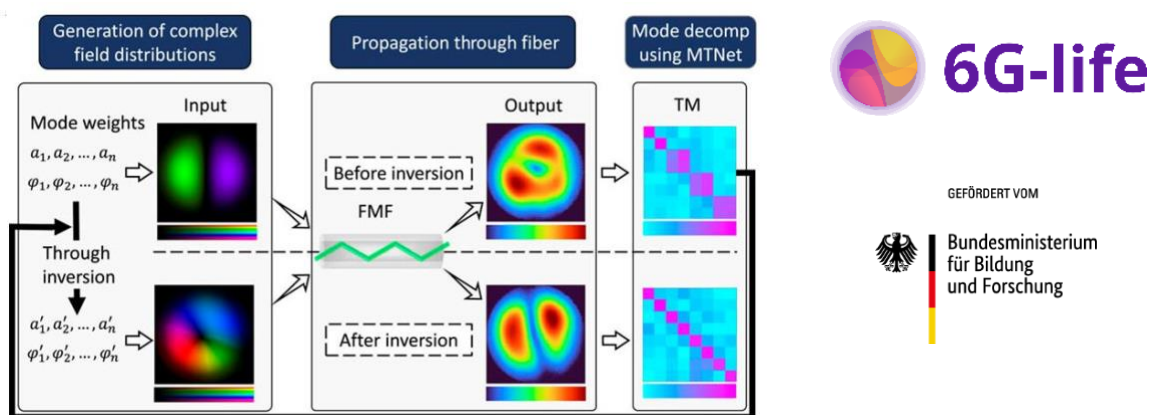

Controlling light propagation through a few-mode fiber using intelligent mode decomposition.

D. Pohle, S. Rothe, N. Koukourakis and J. Czarske, "Surveillance of few-mode fiber-communication channels with a single hidden layer neural network.", Optics Letters 47 (5), 1275-1278, 2022

Q. Zhang, S. Rothe, N. Koukourakis and J. Czarske, "Learning the matrix of few-mode fibers for high-fidelity spatial mode transmission", APL Photonics, 7(6), 066104, 2022

BMBF Quantum Internet of Things (QUIET)

Staff: D. Pohle, A. Geppert, S. Rothe, J. Czarske

Aim: In current 5G and future 6G networks, a data explosion is expected due to massive machine communication, involving thousands of sensors. The increasing energy consumption associated with data growth can also only be managed with strongly performance-enhancing innovations. Quantum characteristics such as entanglement provide the feature of generating perfectly distributed and private randomness, which is a valuable resource for overcoming above mentioned challenges in quantum communications. In addition, quantum computing and quantum sensing provide opportunities on the basis of which quantum communication networks can deliver unique added value by distributing resources locally - and thus transferring them to a cloud. The object of the QUIET project is therefore the prototypical design and realization of an end-to-end system solution that implements the new approaches of quantum technologies in IoT communication networks, from IoT sensors or IoT sensor networks to smart networks and cloud applications, to solve the above mentioned hurdles. Lab MST focuses on the transmission of quantum states from the sensor to a central server. The quantum signals provided by a sensor are to be transported over short to medium distances to a network node using optical fibers. Maintenance of quantum states necessitates transmission with as little loss as possible. Few-mode fibers (FMF) are suitable for transmission, because they have lower coupling losses compared to conventional single-mode fibers. FMFs support multiple transverse modes, which can be used as spatial parallel channels and are proposed for quantum signal transmission. Since only one physical fiber channel is required for simultaneous transmission of multiple quantum states, they can reduce both space and resources per channel. Using an SLM and multiple illuminations, a translation of distributed quantum signals towards a superposition of modes shall be achieved. This approach is called Multiplane Light Conversion.

Period: 06/2022 – 06/2025

Partner: Deutsche Telekom AG (Dr.-Ing. Oliver Holschke), TU Munich (Prof. Holger Boche, Dr.-Math. Christian Deppe, Dr. rer. nat. Janis Nötzel), IFW Dresden (Dr. rer. nat. Caspar Hopfmann), TU Dresden (Prof. Fitzek, Prof. Jamshidi, Prof. Plettemeier)

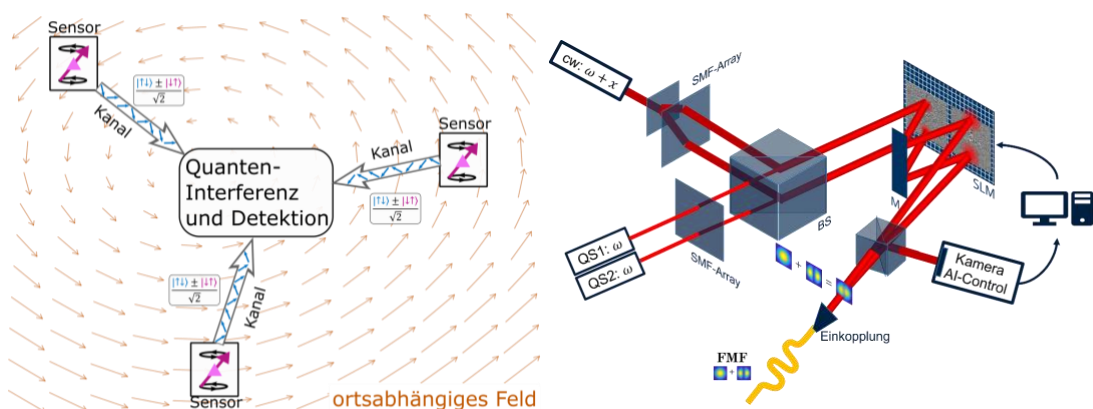

Left: Concept of spatially distributed quantum sensing as an IoT network service. Spin qubits serve as sensors, which transmit the quantum information in the form of photons superimposed at a central server. Right: envisaged approach to translate distributed quantum signals (QS) to a superposition of modes using an SLM and multiplane light conversion.

Q. Zhang, S. Rothe, N. Koukourakis and J. Czarske, "Learning the matrix of few-mode fibers for high-fidelity spatial mode transmission", APL Photonics, 7(6), 066104, 2022

Leibinger Stiftung

Optogenetic Stimulation and Cell Localisation in Three-Dimensional Cell Structures

Staff: F. Schmieder, L. Büttner, J. Czarske

Aim: Optogenetics is a set of methods for the control of the activity of genetically altered cells expressing light-sensitive membrane ion channels. Initiated by the discovery of light-sensitive membrane proteins, this exciting interdisciplinary research area has become a cornerstone instrument in biomedicine, promising great potential for applications ranging from fundamental research to clinical applications like the investigation of neurodegenerative diseases such as Alzheimer's or Parkinson's and the therapy of hearing impairment and the restoration of vision.

Investigations of biological tissue are impaired by light scattering and optical aberrations which increase with sample depth. Both effects lead to increasing problems for single cell stimulation, limiting the achievable depth to only tens of microns. Using femtosecond light sources, this issue can be partially alleviated, but only a local correction of the tissue-penetrating wavefront will increase penetration depths beyond classical limits.

The aim of this project is the adaption of wavefront shaping techniques to the subject of optogenetics. Using suited spatial light modulators and computational optics methods, the goal is to reduce aberrations and light scattering to enhance the penetration depth for optogenetic stimulation. Incorporating computational hardware into measurement and control, a self-parametrization can be achieved to both correct system and sample aberrations and to adapt light patterns to excitation patterns in cell clusters. Using femtosecond light sources, we want to set up a closed loop control system observing reactions of a cell cluster to light stimulation, deriving parameters to adapt the next stimulus and activating the next stimulus. This paves the way for future applications e.g. as an optical pacemaker.

Period: 11/22 – 10/24

Partner: Olaf Bergmann, Research Group Cell-based Model Systems, Department of Pharmacology and Toxicology, University Medical Center Goettingen

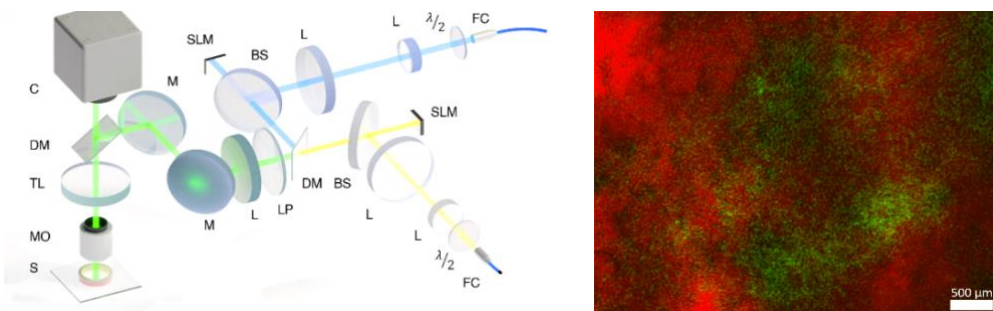

Left: Schematic of a holographic illumination setup for the simultaneous stimulation and inhibition of optogenetically altered cells. Right: Sample image of a cardiomyocyte cell culture (red) overlaid with temporally resolved contraction strength (green) passing over the sample in waves.

DFG Optogenetic Stimulation and Cell Localisation in Three-Dimensional Cell Structures

Staff: F. Schmieder, G. Hartl, L. Büttner, J. Czarske

Aim: Disturbances in the signal transmission are a main cause for heart arrhythmia and deadly ventricular fibrillation. However, the processes generating and interrupting these events are not fully understood yet. Optogenetics – a set of methods encompassing genetic and optical tools for the light-mediated control of cell characteristics – is a promising approach to induce, observe and control irregular signal transmission in in-vitro experiments in a spatially and temporally targeted manner for a deeper phenomenological understanding. The goal of this project is to provide the necessary tools for understanding signal transmission in three-dimensional in vitro cardiomyocyte cell structures. To this end, several approaches will be followed. First, three-dimensional optogenetic stimulation will be realized using non-linear two-photon processes to achieve cell-sized optical confinement in deep tissue (hundreds of microns). This approach will be extended using the method of temporal focusing to achieve a simultaneous stimulation of larger cell patches or volumes, guaranteeing the necessary temporal resolution for a 3d control of excitation waves in cardiac tissue.

To observe excited contraction waves in three dimensions without scanning for high temporal resolution, we will apply 3d localization microscopy and tracking of fluorescently labeled cell nuclei using the approach of point spread function engineering. Here, we will initially employ the method of the double-helix point spread function, which is quite established in localization microscopy and flow measurement. Using deep neural networks for location deconvolution, we will investigate limitations regarding achievable observation depth in relation to scatter/fluorescent particle density.

Period: 10/2023 – 10/2026

Partner: Olaf Bergmann, Research Group Cell-based Model Systems, Department of Pharmacology and Toxicology, University Medical Center Goettingen

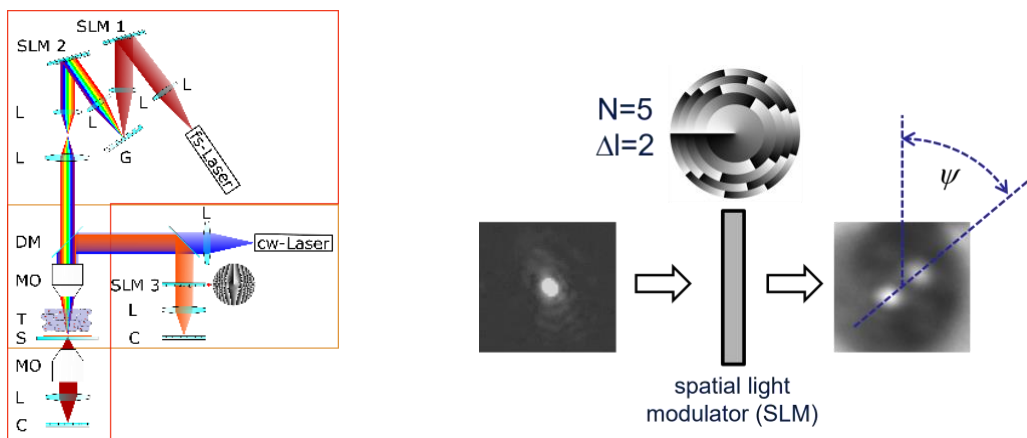

Left: Schematic of setup for simultaneous 3d targeted single cell stimulation and single shot 3d localization microscopy. Right: Principle of 3d localization microscopy with point spread function engineering. Single image points are converted to double spots using a special phase mask in fourier space. The depth of the light source can be estimated from the orientation angle ψ between the double spots which changes along the optical axis.

TUD H2 Lab Investigation of dynamics of hydrogen gas bubbles at microelectrodes in electrolysis using 3D optical flow measurement techniques and adaptive optics

Staff: F. Bürkle, L. Büttner, J. Czarske

Aim: Gas-evolving electrodes are a central element in technologically important processes such as chlor-alkali or alkaline water electrolysis. However, an in-depth understanding of bubble nucleation, growth, coalescence and bubble detachment is not yet achieved. The studies aim on fundamental understanding of bubble dynamics, especially single hydrogen bubble generated by water electrolysis at a microelectrode. Electrochemical investigations are supported by high-speed optical imaging, velocity and temperature measurements and numerical simulation in cooperation. Previous studies focused on the electrolyte flow around the growing bubbles and size and shape measurements by shadowgraphy. It was found that droplets are generated during bubble growth allowing for optical flow measurements by Particle Tracking methods.

The goal of the project is to track and evaluate the internal flow of growing hydrogen bubbles at microelectrodes. It is assumed that the flow inside the bubble is three-dimensional requiring a 3D measurement technique. Hence, helical Particle Tracking Velocimetry shall be employed. Difficulties arise due to the spherical bubble shape resulting in strong aberrations requiring a compensating optical system or simulations to correct the aberrations which would otherwise lead to high systematic deviations. Furthermore, the process of bubble growth is transient resulting in changing radii of curvature during the process making the use of adaptive optical systems feasible.

Period: 07/2022 – 06/2023

Partners: Prof. Kerstin Eckert, Dr. Karin Schwarzenberger, Dr. Xuegeng Yang, TUD/HZDR

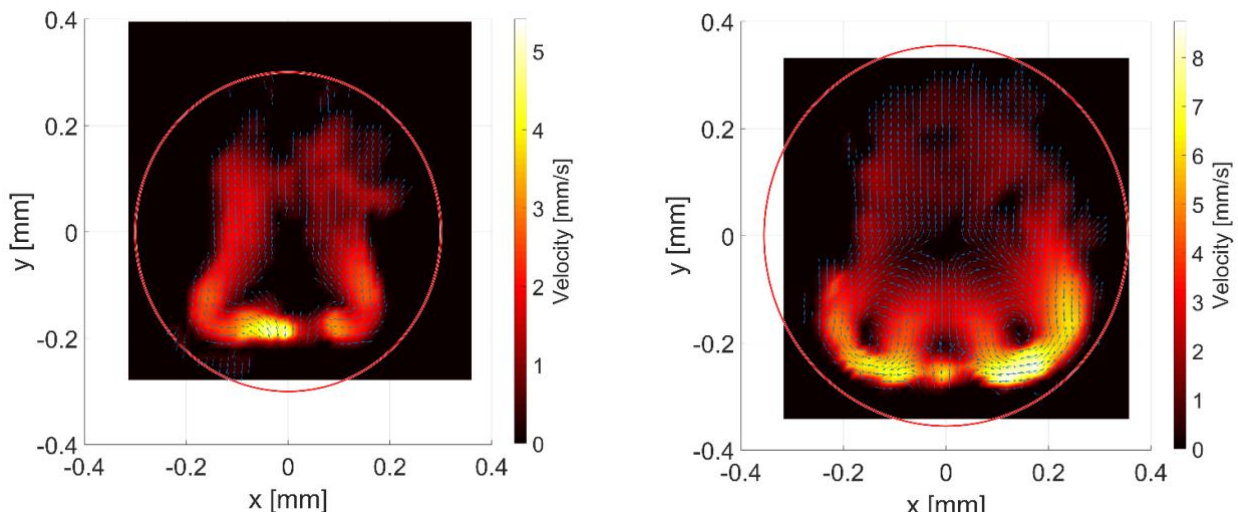

Vector plots of the flow field of a hydrogen bubble growing at a microelectrode with an applied potential of -7 V. The left picture shows the flow at 60 % of the growing time, the right picture right before detachment. The circles indicate the shape of the bubble.

F. Bürkle, A. Bashkatov, A. Babich, X. Yang, K. Eckert, J. Czarske, L. Büttner, „ Measurement of the internal flow in hydrogen bubbles using a model-based aberration correction”, Beitrag 12, 30. Fachtagung “Experimentelle Strömungsmechanik”, München, 5.-7.9.2023

DFG Investigation of the transition of aerosol particles in liquids with an adaptive optical measurement technique for highly dynamic phase boundaries

Staff: F. Bürkle, L. Büttner, J. Czarske

Aim: In many industrial and medical applications the transport of aerosol particles in gas flows and their transition into a liquid phase play a significant role. Examples are wet scrubbers as a cost efficient alternative for the filtering of fine dust out of exhaust gases or aerosols from metal coating processes. To achieve this, an air flow containing particles is led through a washing liquid. In the same way, viral particles can be filtered. In future, miniaturized and portable separators may be used to fight pandemics. However, the models for the description of particle separation are not sufficiently accurate for particles in the micrometer range. Previous works show that there might be a significant dependence of the particle separation and the involved flow fields and the shape of the phase boundary, which are not considered yet. To investigate the flow inside gas bubbles with a varying surface, adaptive optical systems are necessary. In this work a camera-based, 3D-method will be realized and used to measure the flow inside the bubbles as well as in the surrounding liquid. An especially interesting flow can be found in and around a stabilized Taylor bubble. The particle separation on a fixed droplet inside an air flow will be investigated as well.

Period: 07/2022 – 06/2025

Partners: Rhandrey Maestri, Dr. Grégory Lecrivain, Prof. Dr.-Ing. habil. Dr. h. c. Uwe Hampel, Institute of Fluid Dynamics, Helmholtz-Zentrum Dresden-Rossendorf (HZDR)

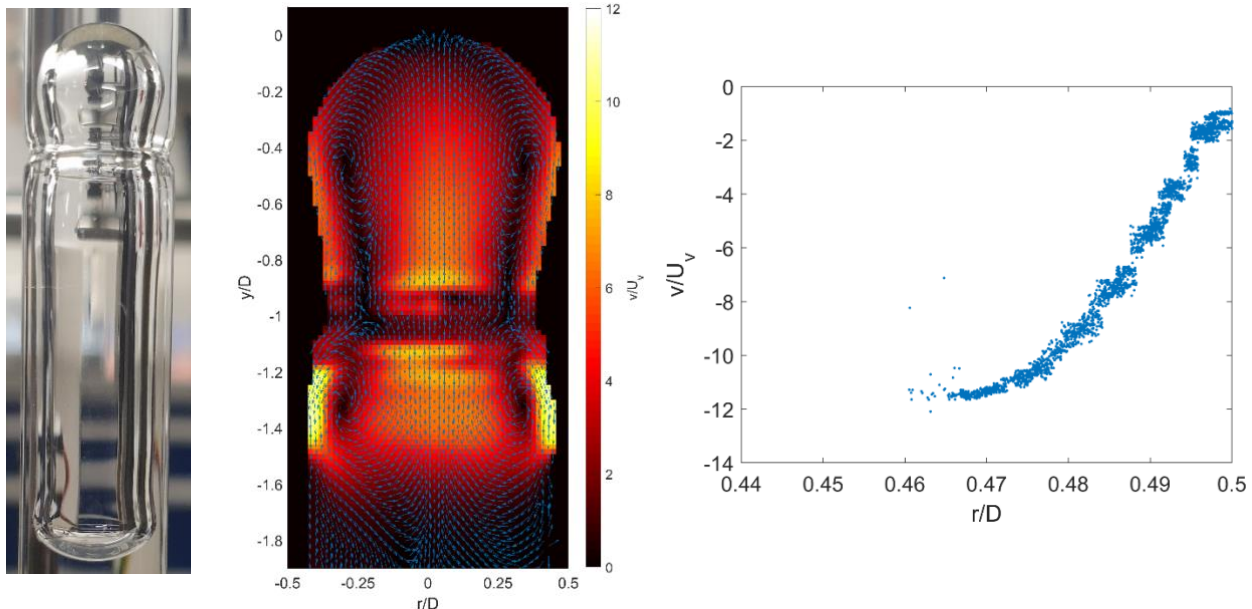

Left: Picture of a Taylor bubble inside a constriction, Middle: Gas flow field of the Taylor bubble head. Right: Liquid film flow velocity profile directly below the constriction measured with double-helix particle tracking velocimetry.

H. Radner, J. Stange, L. Büttner, J. Czarske, "Field programmable system-on-chip based control system for real-time distortion correction in optical imaging", IEEE Transactions on Industrial Electronics 68(4), 3370-3379, 2021
F. Bürkle, G. Lecrivain, R. Maestri, J. Czarske, L. Büttner, "Investigation of the flow inside a Taylor bubble in a tube with a short constriction", 19th Multiphase Flow Conference, 2023

**AiF Transport processes at oscillating droplets and liquid films –
Development of an adaptive measurement technique and a code-based
description**

Staff: C. Bilsing, L. Büttner, J Czarske

Aim: Various technical processes in chemical, automotive, energy and building services potential for optimizing such processes. The aim of this research project lies in the development of a code-based description of the behavior of liquid films and droplets on substrates in the presence of a grazing gas flow. To this end, a three-dimensional, camera-based flow measurement technique with included adaptive-optical real-time aberration correction will be realized. Flow measurements in droplets through the fluctuating phase boundary will be conducted for the first time with unprecedented accuracy. Together with numeric simulations of moving films and droplets, new findings on the behavior of unstable droplets and films are expected. This will lead to a code-based description, which can be applied by small and medium-sized enterprises to describe industrial cleaning, entrainment or material exchange processes.

Period: 08/2020 – 12/2023

Partner: Dr. Sebastian Burgmann, University of Wuppertal

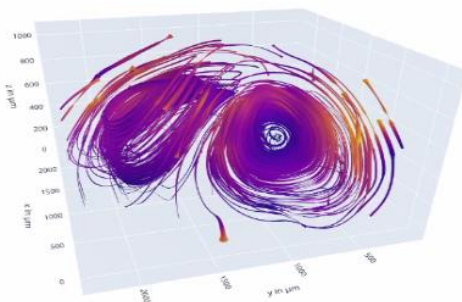

A grazing flow induces a complex flow pattern in droplets which was measured three-dimensionally for the first time in this project. The tilt of the vortex pairs could be resolved experimentally for the first time.

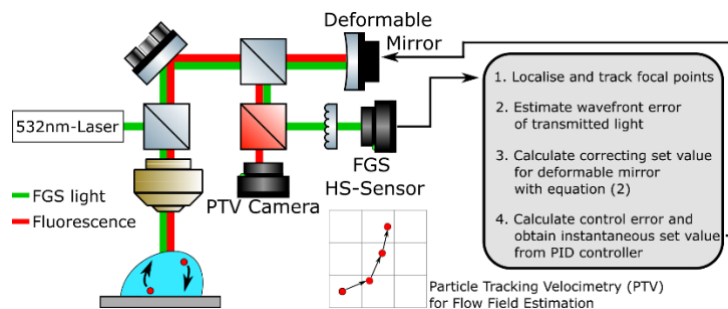

Measurements through the fluctuating phase boundary can be performed for the first time using adaptive optics, here a deformable membrane mirror.

Bilsing, C., Radner, H., Burgmann, S., Czarske, J., & Büttner, L. (2022). 3D imaging with double-helix point spread function and dynamic aberration correction using a deformable mirror. *Optics and Lasers in Engineering*, 154, 107044.

Bilsing, C., Büttner, L., Czarske, J., Janoske, U., Burgmann, S. (2022). 3D-PTV-Messung in einem oszillierenden Tropfen mittels Doppelhelix-Punktspreizfunktion (DH-PSF). Fachtagung „Experimentelle Strömungsmesstechnik“ 6. – 8. September 2022, Ilmenau

Bilsing, C., Radner, H., Büttner, L., Burgmann, S., Metzmacher, A. & Czarske, J., „Neuartiges Lasermesssystem mit adaptiver Bildkorrektur unter Nutzung von helikalen Wellenfronten und eines deformierbaren Spiegels“, 122. Jahrestagung der DGaO, Preisträgervortrag NWP4, Bremen, 21.–23.09.2021

Bilsing, C., Büttner, L., Burgmann, S., & Czarske, J. W. (2023, October). High-speed 3D particle tracking with dynamic aberration correction using a Fresnel guide star. In *Unconventional Imaging, Sensing, and Adaptive Optics 2023* (Vol. 12693, p. 126930I). SPIE.

AiF Measurement methods and modeling spray cleaning – Development and application of an adaptive 3D camera measurement system for the semi-analytic modeling of spray cleaning processes.

Staff: G. Hartl, L. Büttner, J. Czarske

Aim: Spray cleaning is an essential process step in the manufacturing industry for food, beverages and pharmaceuticals. More efficient processes lead to increased efficiency, economics and decreased ecological impact. In this project, we want to analyze the process parameters and develop methods to acquire for the first time high-resolution data throughout the cleaning process, including the film flows and contamination phantoms. A novel highspeed 3D camera-based technique using engineered double-helix point spread function will reveal the dynamics in the most relevant processes in spray cleaning. In three measurement campaigns the data for creation of a semi-analytic model of the cleaning process will be generated. Flow measurements of unstructured surfaces and structured phantoms will be analyzed with tracer particles and shadow imaging. For the contamination samples, embedded fluorescent particles are used. The measurement accuracy will be further increased by adaptive optics for real-time aberration correction, and deep learning methods for analysis of the data.

Period: 01/2022 – 12/2024

Partners: Dr. Hannes Köhler, Manuel Helbig,
Professur für Verarbeitungsmaschinen / Verarbeitungstechnik (VAT), TU Dresden

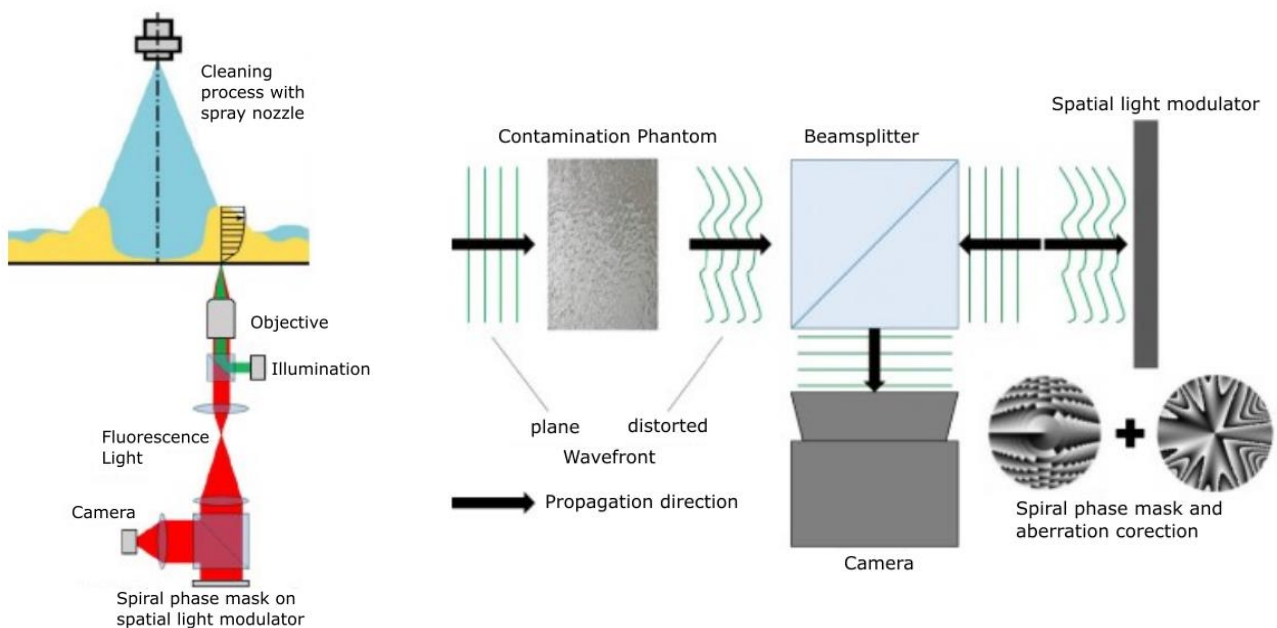

DFG Lensless holographic endoscopy with self-calibration

Staff: E. Scharf, J. Dremel, R. Kuszmierz, J. Czarske

Aim: Flexible endoscopes are used in medicine and industrial applications for minimal invasive imaging. They employ miniaturized optics in the probe tip and a coherent fiber bundle (CFB) with 10,000 to 100,000 fiber cores for transferring the image outwards. The working principle and setup result in a pixelated image due to the limited core number as well as a fixed image plane. Furthermore, the optics in the probe tip limit the minimum diameter of the probe tip to several millimeters. With the approach of the lensless holographic endoscope, it is possible to eliminate or greatly improve the disadvantages of pixilation, fixed image plane and limited minimal diameter. The holographic endoscope does not use the single fibers to transfer single image points out of the sample. They are used to transport light from a laser into the interior of the sample. Due to the multitude of fibers and the wave character of light, the lensless probe tip can be regarded as a phased array. Using a Spatial Light Modulator (SLM) outside of the CFB it is possible to control the phase through each fiber core individually. While a new calibration is needed after each movement of the CFB, we found a way to calibrate continuously and in-vivo, without access to the probe tip. One single fiber core acts as a guide star through a semi-reflective plane (see Fig. 1). Such that, the relative phase delays between neighboring cores are determinable via holography. The SLM is used to compensate distortions within the CFB and to shape the out coming beam. Thus, it is possible to create a free-moving focus to scan the object. Like the functionality of a scanning microscope, an image can be assembled from the backscattered light of the individual focus positions. The approach enables setups with sub-millimeter diameters, sub-micron resolution and 3D imaging capability. In addition to its use as an endoscope, this technology can also be used for laser surgery, optogenetics and optical tweezers.

Period: 11/2020 – 12/2024

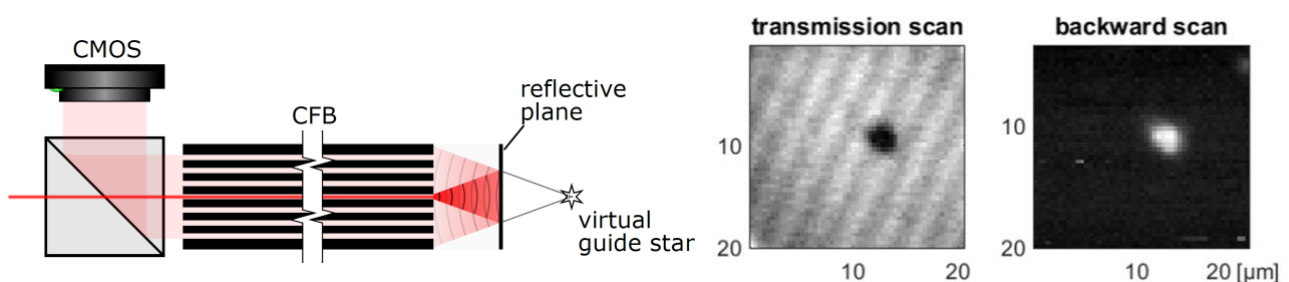

Fig. 1

Fig. 2

Left: Scheme virtual guide star calibration. Right: Endoscopic scan of fluorescent particle with diameter of 1 μm .

R. Kuszmierz, E. Scharf, N. Koukourakis, and J. Czarske, "Self-calibration of lensless holographic endoscope using programmable guide stars", *Opt. Lett.* 43, 2997-3000 (2018).

E. Scharf, J. Dremel, R. Kuszmierz, J. Czarske, "Video-rate lensless endoscope with self-calibration using wavefront shaping", *Optics Letters* 45(13), 3629-3632, 2020

R. Kuszmierz, E. Scharf, D. F. Ortigón-González, T. Glosemeyer, J. Czarske. Ultra-thin 3D lensless fiber endoscopy using diffractive optical elements and deep neural networks. *Light: Advanced Manufacturing*

Dremel, Jakob, Scharf, Elias, Kuszmierz, Robert and Czarske, Jürgen. "Minimal-invasive faseroptische Endomikroskopie für die Medizin" *tm - Technisches Messen*, vol. 89, no. s1, 2022, pp. 25-30. <https://doi.org/10.1515/teme-2022-0068>

DFG Investigation of damaged fibre-reinforced high-speed rotors using in-situ measurement systems

Staff: J. Lich, R. Kuschmierz, J. Czarske

Aim: Fibre-reinforced composites offer excellent properties such as very high specific strength and stiffness as well as high freedom of design due to their anisotropy and gradual damage behavior. Therefore, they are predestined for new high-performance rotors, for example in turbomachinery or centrifuges. However, problem-oriented design tools for the reliable prediction on durability, reliability and energy efficiency of the rotor are still lacking. The aim of the project is to find the fundamental relationship between damage state and dynamic behavior of fast rotating fibre-reinforced rotors. This requires the development of novel measurement systems that allow the simultaneous in-situ measurement of damage state and modal behavior during rotation. Rotor expansion is measured with submicron uncertainty by our unique Multipoint-Laser-Doppler-Distance Sensor. We additionally measure the in-plane strain field and the out-of-plane vibration by reading out diffraction gratings on the rotor surface. To validate and calibrate numerical models developed by our partner "Institut für Leichtbau und Kunststofftechnik", we further reduce the measurement uncertainty of the Diffraction Grating Sensor and expand its applicability to complex rotor geometries. Furthermore, techniques for the volumetric measurement of local deformations and damages will be qualified and applied for the first time at fast rotating structures together with our partner "Klinisches Sensing und Monitoring".

Period: 10/2017 – 04/2021, 11/2021 – 11/2024

Partner: Institut für Leichtbau und Kunststofftechnik - TU Dresden, Prof. Gude
Arbeitsgruppe Klinisches Sensing und Monitoring – TU Dresden, Prof. Koch

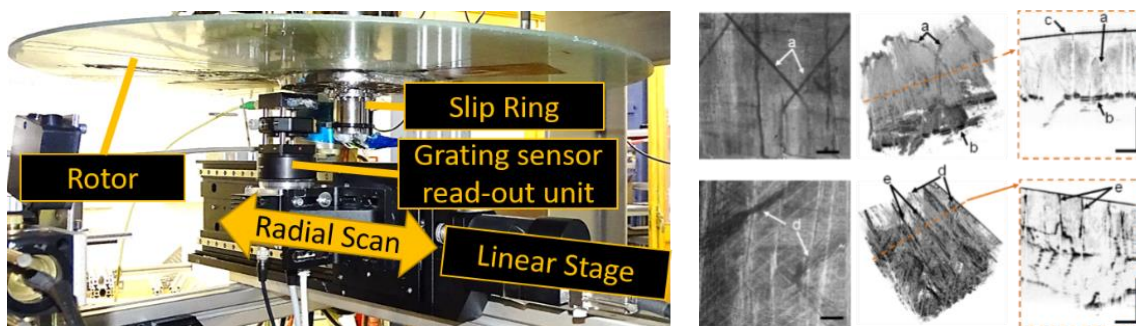

Diffraction Grating Sensors measuring in- and out-of-plane FRP rotor deformation field and vibration at >270 m/s with 20 μe and 15 μrad precision (left). OCT images of internal FRP rotor structure, showing delamination (b) and cracks (e) (right) due to overload.

Lich, Julian, et al. "Spatially Resolved Experimental Modal Analysis on High-Speed Composite Rotors Using a Non-Contact, Non-Rotating Sensor." *Sensors* 21.14 (2021): 4705.

Filippatos, Angelos, et al. "Design and testing of polar-orthotropic multi-layered composites under rotational load." *Materials & Design* (2021): 109853.

Julian Lich, Tino Wollmann, Angelos Filippatos, Maik Gude, Jürgen Czarske, Robert Kuschmierz, "Diffraction-grating based in situ displacement, tilt and strain measurements on high-speed composite rotors", *Applied Optics*, 58(29), 8021-8030, (2019)

DFG Minimally Invasive 3D-Imaging using a diffuser and neural networks

Staff: J. Lich, T. Glosemeyer, R. Kuschmierz, J. Czarske

Aim: The aim of the project is to fundamentally investigate a novel technique for minimally invasive endoscopy. Conventional fiber endoscopes are based on the transmission of intensity patterns through imaging waveguides and on imaging optics with a fixed focal distance for 2D imaging. A paradigm shift towards minimally invasive, single-shot, 3D measurements will be pursued by substituting the imaging optics with a diffuser. The diffuse scattering of light is used to code 3D object information in 2D speckle patterns and relay this information through imaging waveguides. The decoding will be realized in an advantageous manner by neural networks and deep learning.

Endoscopy is of high importance for in-vivo deep-tissue examinations in biological research, for instance in neurosurgery. Stereotactic needle biopsies are performed to enable ex-vivo auto fluorescence microscopy for brain tumor classification. The time delay between biopsy, measurement and diagnosis requires multiple surgeries. A miniaturized endoscope on the other hand can enable an in-vivo-pathology by 3D autofluorescence mapping.

Due to their high 3D displacement resolution, miniaturized diffuser endoscopes can be furthermore used for 3D-3C blood flow measurements.

Period: 04/2021-04/2024

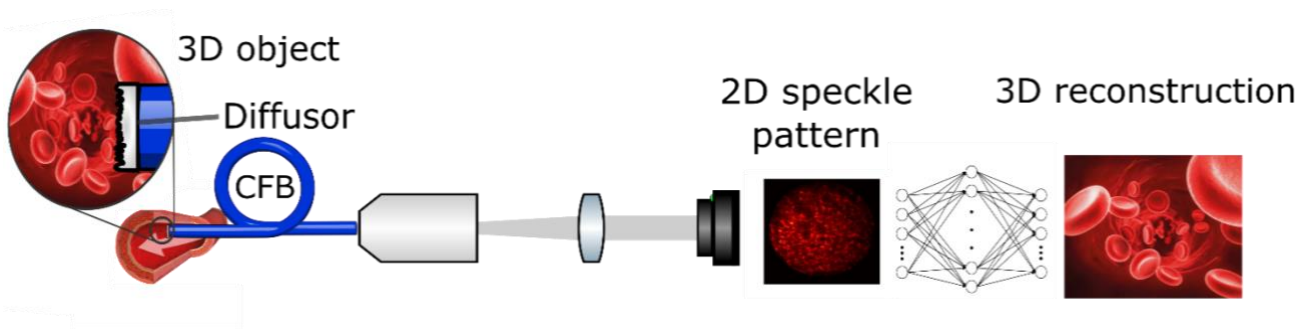

The 3D object is encoded by a diffuser to a 2D speckle pattern which is transmitted through a CFB to a camera. The 3D object is then reconstructed by a neural network.

R. Kuschmierz, E. Scharf, D. F. Ortégón-González, T. Glosemeyer, J. Czarske. Ultra-thin 3D lensless fiber endoscopy using diffractive optical elements and deep neural networks, [J]. Light: Advanced Manufacturing. doi: 10.37188/lam.2021.030, (2021)

AIF Needle-shaped lensless holographic endoscope (HoloScope)

Staff: E. Scharf, T Wang, R. Kuschmierz, J. Czarske

Aim: Thin and flexible endoscopes for minimally invasive medical diagnostics and therapy only allow for 2D imaging so far while 3D endoscopes exceed the required diameters for minimally invasive applications. Aim of the project “HoloScope” is the realization of endoscopes with diameters down to 300 μm, which allow for 3D imaging with cellular resolution. Current approaches for lensless holographic endoscopes rely on complex setups and programmable optics, are difficult to calibrate, expensive, not real time and generally not suitable for applications outside of research labs. Furthermore, commercially available fiber bundles used in these setups are ill suited for the applied phased array principle.

This project aims to overcome some of these issues, by implementing real time and in-situ calibration and closed loop control. Especially novel fiber designs are investigated in cooperation with Hannover Institute of Technology (HITec) of Leibniz-University Hannover, in order to achieve superior imaging quality as well as robustness. This project is additionally supported by 12 companies, including 8 MSEs, as well as 2 clinics.

Period: 08/2021-03/2024

Partner: Dr. M. Steinke & Prof. D. Ristau, Hannover Institute of Technology (HITec), Leibniz-University Hannover

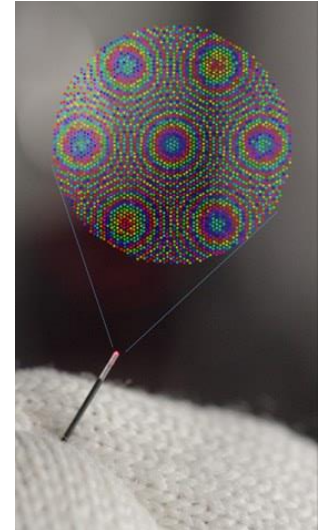
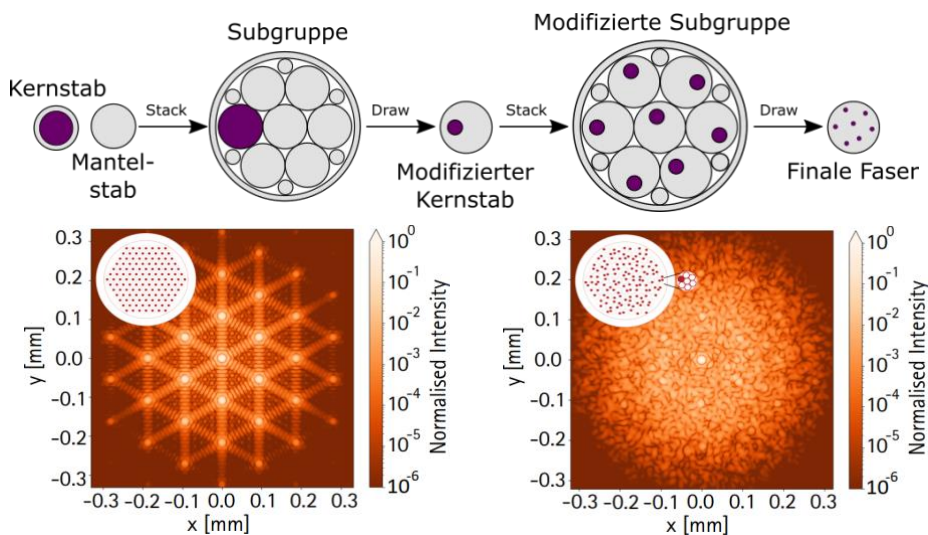

Top: drawing process of aperiodic image guides (stack and draw). Bottom – left: far field of existing fiber with periodically arranged fibers cores. Higher diffraction orders result. Bottom-right: far field of novel fiber with aperiodically arranged fiber cores suppresses higher diffraction orders.

Lensless holographic endoscope: Magnification shows the light phase on the fiber for far field focusing

R. Stephan, M. Steinke, A. Rühl, R. Kuschmierz, K. Hausmann, M. Ließmann, D. Ristau, and J. Czarske, „Design studies of aperiodic multicore fibres for lensless endoscopy“, ePoster ETu2A.30, Advances in Microscopic Imaging, OSA European Conferences on Biomedical Optics, 2021

E. Scharf, R. Stephan, M. Steinke, R. Kuschmierz, D. Ristau, and J. Czarske, „Nadelförmiges linsenloses holografisches Endoskop“, ePoster, F.O.M.-Konferenz 2021, 2021

EKFZ In vivo brain tumor diagnostics by adaptive computational lensless fiber endoscopy (BrainAce)

Staff: J. Dremel, T. Wang, J. Czarske, R. Kuschmierz

Aim: In patients with inoperable brain tumors located in eloquent brain regions, histological diagnosis is a prerequisite for the determination of the adjuvant treatment. This requires a minimal-invasive biopsy for histology that requires some days to provide an integrated diagnosis for further clinical decision-making. As a consequence, if the suspicious tissue turns out to be an aggressive brain tumor, the adequate therapy is delayed with negative impact on the patient's prognosis. The development of strategies for direct tumor diagnosis bypassing tissue removal and lengthy pathological evaluation would allow the immediate therapy of affected patients.

We aim to develop and test a prototype of a novel tiny endoscope that probes autofluorescence of brain tissue and allows optical biopsies in situ. In the project, we will research the spectral characteristics of brain tumor fluorescence and miniaturize an endoscopic system while preserving high optical properties. This is achieved by implementation of recent advances in computational optics and programmable light. The development of tissue classification and strategies for integration of AI-supported diagnosis into the clinical workflow will allow successful translation. Moreover, the research may pave the way for future automated brain tumor diagnosis and tumor removal by laser ablation.

Period: 01/2022 – 12/2024

Partners: University Hospital Carl Gustav Carus, Neurosurgery & Division of Medical Biology
Dr. S. Richter, Dr. W. Polanski, Prof. G. Schackert, Dr. O. Uckermann

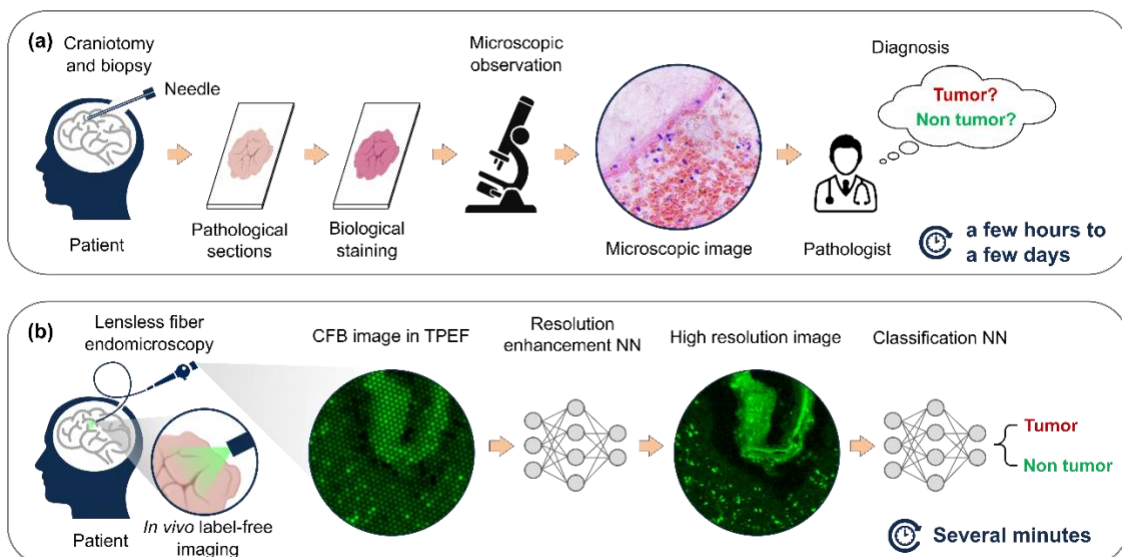

Workflow of biopsy diagnosis and end-to-end diagnosis

Wu, J., Wang, T., Uckermann, O., Galli, R., Schackert, G., Cao, L., Czarske, J., Kuschmierz, R., 2022. Learned end-to-end high-resolution lensless fiber imaging towards real-time cancer diagnosis. *Sci Rep* 12, 18846

DFG Ultrasound measurements through multimode-waveguide based on time reversal for imaging in hot metallic melts

Staff: H. Emmerich, Z. Dou, D. Weik, J. Czarske

Aim: In industrial processes, such as continuous steel casting, the quality of the end products depends on the melt flow and structure. Therefore, in situ imaging of opaque melts under harsh conditions is important. Conventional ultrasound measurement systems, which are usually suitable for imaging in opaque fluids, cannot be operated at temperatures beyond Curie temperature of the ultrasound transducer.

An approach is to use a multimode waveguide as a temperature gradient, which spatially separates the sensor from the hot measurement fluid. To overcome the complex ultrasound propagation through the waveguide the time reversal method is used. The time invariance of the wave equation in an unknown, linear and nearly lossless medium allows spatiotemporal refocusing to the initial point. However, the planar imaging would require costly in situ calibration, because each point of interest need to be calibrated with a beacon.

A reduced, non-invasive, ex situ calibration can be achieved by applying the time reversal virtual array method. Therefore only a limited set of precalibrated points at the waveguide-measurement volume interface are needed, which form the virtual array. The virtual array can be conceptually treated as a phased-array for the imaging behind the waveguide. This allows the application of conventional signal processing strategies, such as transmit and receive beamforming to increase the resolution of an image and ultrasound Doppler velocimetry for flow estimations.

Period: 12/2023 – 11/2026

Partner: Helmholtz-Zentrum Dresden-Rossendorf, Dr. S. Eckert

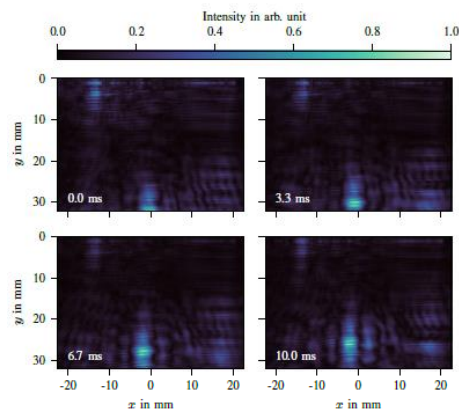
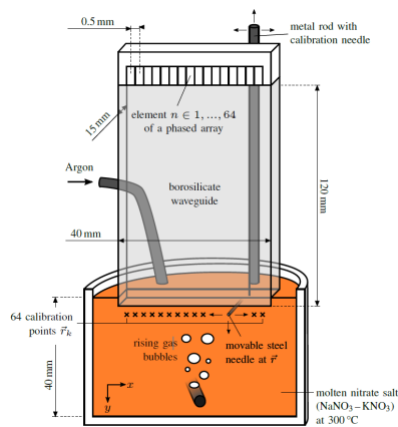

Cross-section of the experimental setup: A phased array was connected to the end of a borosilicate waveguide and calibrated in the hot melt with a moving needle. Observation of rising gas bubbles in molten salt at 300 °C.

L.Grüter, R. Nauber, J. Czarske, „Ultrasonic Bubble Imaging in Molten Salt Using a Multi-Mode Waveguide and Time Reversal“, IEEE Transactions on Instrumentation and Measurement 71, 2022, Art. no. 4501810.

Z. Dou, L. Grüter, D. Weik, J. Czarske, "Ultrasound Tracking of Gas Bubbles Through a Multi-Mode Waveguide in Hot Melts", 2022 IEEE International Ultrasonics Symposium (IUS), Oct. 2022.

DFG Investigation of thermal boundary layer dynamics in turbulent liquid metal convection by ultrasound localization microscopy of near-wall velocity fields and temperature measurements

Staff: D. Weik, L. Büttner, J. Czarske

Aim: The dynamics and interaction of thermal and viscous boundary layers (BL's) will be studied experimentally in highly turbulent liquid metal convection at small Prandtl numbers using the ternary alloy GalSn ($Pr = 0.03$). Rayleigh-Bénard convection at large Rayleigh numbers of up to $Ra \cong 5 \times 10^9$ is characterized by a fully turbulent flow field, with the temperature field exhibiting significantly more coherence than the velocity field due to the high thermal diffusivity. A crucial role for heat transport in turbulent convection is played by the BL's. Here, a special feature of liquid metals becomes apparent, which has hardly been researched so far: The much thinner viscous boundary layer is embedded in the thermal BL. Therefore, the thermal BL and thus the convective heat transport are strongly influenced by the turbulent large-scale convection (LSC). By means of *Ultrasound Localization Microscopy* (ULM) of near-wall velocities and high-resolution temperature measurements using fiber optic sensors, the interaction between BL's and LSC will be investigated in detail for the first time in liquid metal laboratory experiments. This parameter range has so far been inaccessible by direct numerical simulations. The experiments, in which near-wall temperatures and flow velocities are measured in liquid metals with high resolution, set a new milestone for the understanding of convective transport processes in fluids at small Pr with their numerous applications in geo- and astrophysical flows as well as in engineering systems.

Period: 04/2023 – 03/2026

Partner: Helmholtz-Zentrum Dresden-Rossendorf, Dr. S. Eckert, Dr. T. Vogt

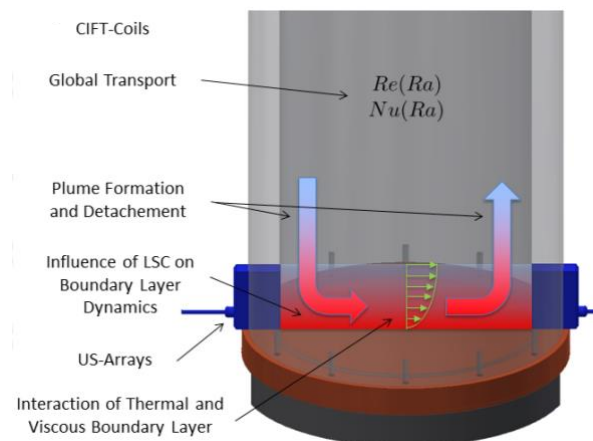
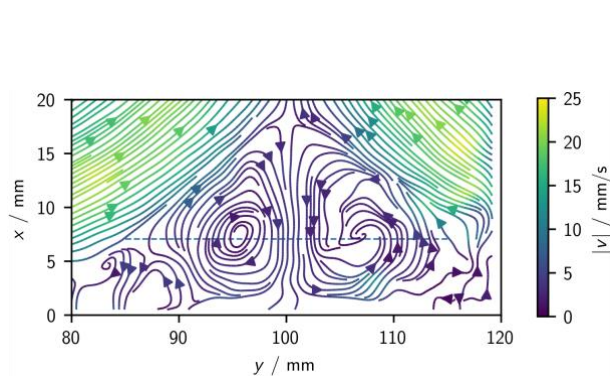

Super-resolution vector flow imaging of a recirculation area in a liquid metal convection.

Projected convection experiment for thermal and viscous boundary layer measurements.

D. Weik, L. Grüter, D. Rübiger, S. Singh, T. Vogt, S. Eckert, J. Czarske, L. Büttner, „Ultrasound Localization Microscopy in Liquid Metal Flows”, Applied Sciences 12.9, 4517, 2022.

D. Weik, L. Grüter, D. Rübiger, S. Singh, T. Vogt, S. Eckert, J. Czarske, "Ultrasound Localization Microscopy by Nonlinear Adaptive Beamforming – a Case Study for Super-Resolved Flow Fields in Liquid Metal Experiments", 2022 IEEE International Ultrasonics Symposium (IUS), Oct. 2022.

AIF Monitoring the water content in polymer electrolyte membrane fuel cells using surface acoustic waves

Staff: Z. Dou, D. Weik, J. Czarske

Aim: Optimizing water management is crucial for enhancing the lifespan and efficiency of low-temperature polymer electrolyte membrane fuel cells (NT-PEMFCs). Current methods for assessing water balance are expensive, complex, and lack real-time monitoring capabilities. In our research project, we're investigating a cost-effective method to detect water distribution with high temporal and spatial resolution during NT-PEMFC operation.

Our novel approach relies on measuring changes in the propagation properties of surface waves in the fuel cell when droplets are present in the channel. This enables us to detect the position and quantity of water droplets within the channel. By employing interdigital transducers across multiple transmission paths, we can deduce water distribution within the cell. This method has the potential to be cost-effective and widely applicable in NT-PEMFCs with metallic bipolar plates.

The collaborative project involves TU Dresden, ZBT, and IFW, aiming to develop a functional demonstrator for measuring water coverage on a fuel cell up to TRL 4. This includes the development of highly integrated ultrasonic transducers in the complex fuel cell system, along with validation and calibration processes. The practical relevance of the project will be demonstrated by applying the method in an operational fuel cell.

The diversity of companies in the project advisory committee highlights the project's promise for small and medium-sized enterprises. Significant advancements are expected in areas such as sensor technology, bipolar plate optimization, and fuel cell design. Given the high integration of components, close collaboration within the industry is essential, with the project advisory committee serving as an ideal platform for fostering partnerships and knowledge exchange.

Period: 12/2023 – 5/2026

Partner: ZBT Duisburg, Dr. L. Tropsf, Dr. V. Lukasek
IFW Dresden, Dr. H. Schmidt

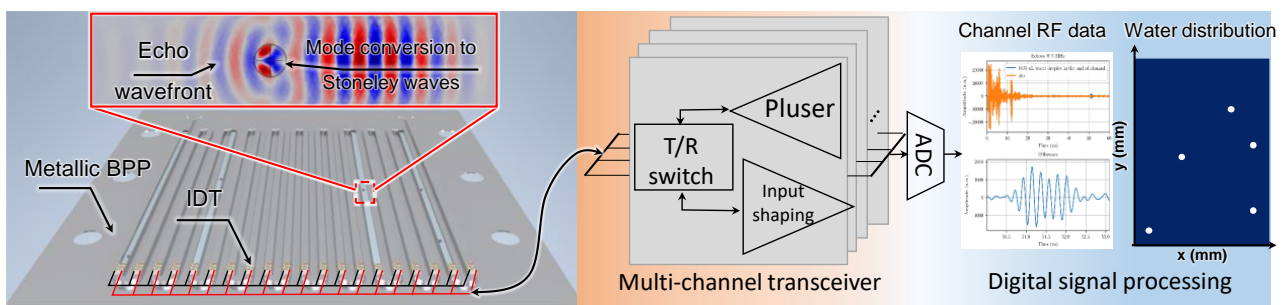

Schematic of the proposed measurement system. Pulse-echo-localization of water droplets is conducted by means of surface acoustic waves and a transducer array.

Z. Dou, B. Fang, L. Tropsf, H. Hoster, H. Schmidt, J. Czarske and D. Weik, "A Water Monitoring System for Proton Exchange Membrane Fuel cells Based on Ultrasonic Lamb Waves: An Ex-situ Proof of Concept", IEEE Transactions on Instrumentation and Measurement 72 (2023), 9601112

DFG High-speed 4D measurement of thermoacoustic oscillations

Staff: J. Gürtler, R. Kuschmierz, J. Czarske

Aim: During the combustion of sustainable fuels, such as green hydrogen for stationary gas turbines, instabilities occur in the form of thermoacoustic oscillations. To ensure safe and efficient turbine operation, a deeper understanding of these oscillations is necessary.

For this purpose, scientists from the Chair of Measurement and Sensor Systems Engineering at TU Dresden and the Institute of Thermal Turbomachinery and Machine Dynamics at TU Graz want to develop and apply new measurement and evaluation techniques. Using modern high-speed camera technology and deep learning based tomographic reconstruction.

The aim of the project is to perform laser-optical measurements inside such oscillating flames, with high demands on the measurement technology due to the necessary spatial (3D, $\leq 500 \mu\text{m}^3$) and temporal ($\leq 10 \mu\text{s}$) resolutions. The cooperation project is funded by the Deutsche Forschungsgemeinschaft (DFG) as well as the Austrian Science Fund (FWF) under the project numbers CZ 55/50-1 and I 5392-N.

Period: 11/2022 – 10/2025

Partner: TU Graz, Prof. Woisetschläger

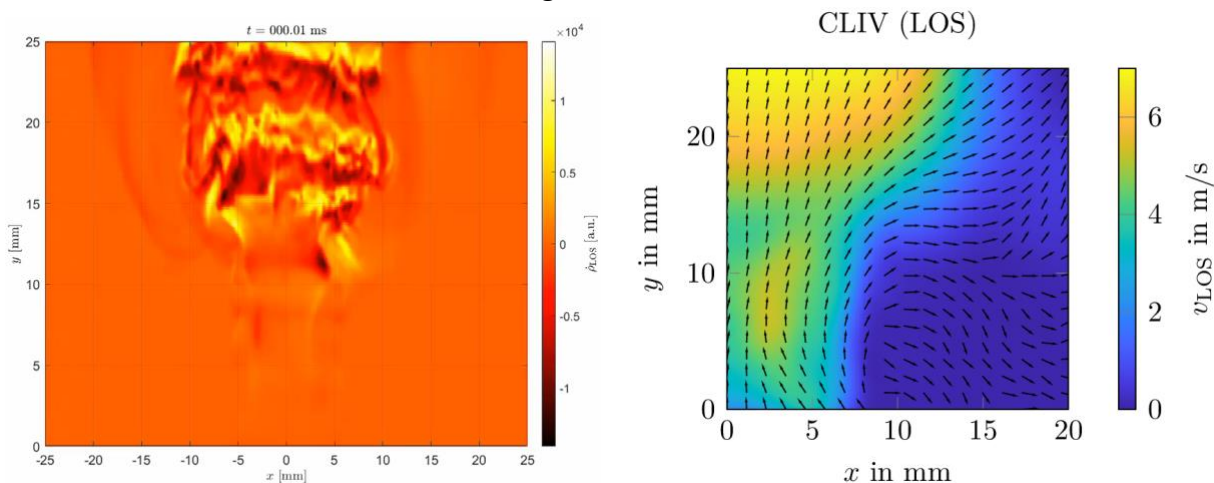

Left: Time resolved density derivative measured line-of-sight in a swirl-stabilized flame. Right: Integral mean velocity, calculated from the line-of-sight density measurement using PIV signal correlation.

Greiffenhagen, F., Peterleithner, J., Woisetschläger, J., Fischer, A., Gürtler, J., Czarske, J., „Discussion of laser interferometric vibrometry for the determination of heat release fluctuations in an unconfined swirl-stabilized flame“. In: Combust. Flame 201 (2019), S. 315–327. doi: 10.1016/j.combustflame.2018.12.019.

Greiffenhagen, F., Woisetschläger, J., Gürtler, J., Czarske, J., „Quantitative measurement of density fluctuations with a full-field laser interferometric vibrometer“. In: Exp. Fluids 61.1 (2020), S. 9. doi: 10.1007/s00348-019-2842-y.

Gürtler, J., Greiffenhagen, F., Woisetschläger, J., Kuschmierz, R., Czarske, J., „Seedingless measurement of density fluctuations and flow velocity using high-speed holographic interferometry in a swirl-stabilized flame“. In: Opt. Lasers Eng. 139.September (2021), S. 106481. doi: 10.1016/j.optlaseng.2020.106481.

Rothkamm, O., Gürtler, J., Czarske, J., Kuschmierz, R., „Dense U-Net for Limited Angle Tomography of Sound Pressure Fields“. In: Appl. Sci. 11.10 (2021), S. 4570. doi: 10.3390/app11104570.

AiF In-process monitoring of material flows in froth flotation with model-based ultrasonic measurement technology

Staff: H. Emmerich, L. Büttner, D. Weik, J. Czarske

Aim: In 2016, about 20 billion liters of water were used, only to extract copper as a raw material. The process used is the froth flotation. Grained materials are being separated by the use of surfactant solutions. Ascending bubbles transport the hydrophobic materials to the surface, consisting of a bulk foam layer. Due to different material and water qualities, a robust effective process is only partly possible. Information about the material flow might increase these factors. Our aim in that project is to implement a measuring system, giving information about the foam's consistence and the material flow. Conventional optical measurements or level sensors provide a too low penetration depth in opaque bulk foam or give too little information about the foam parameters respectively. Therefore, we use an in-situ ultrasound measurement system. An ultrasound array is used to create a 2D-image. Analyzing the variations in the propagated (transmitted/reflected) ultrasound signal due to different foam parameters as liquid fraction, bubble size or the amount of particles, we are able to draw retrospective conclusions about those parameters. Using different signal processing tools as Doppler Analysis we gain information about the particles velocity and their moving direction. Combining those monitored values, we can infer a statement about the material flow. Thereby we are one step closer to a control loop that potentially increases the yield and saves energy and resources.

Partner: Leon Knüpfer, Dr. Sascha Heitkam, Institute of Fluid Dynamics
Helmholtz-Zentrum Dresden - Rossendorf (HZDR)

Period: 06/2020 – 10/2023

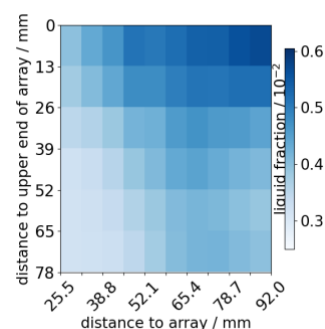
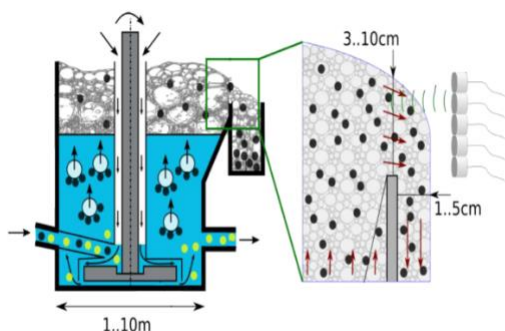

Scheme of a flotation cell and the measurement setup

Spatio-temporally resolved measurement of the liquid fraction

Nauber, Richard & Büttner, Lars & Eckert, Kerstin & Fröhlich, Jochen & Czarske, Jürgen & Heitkam, Sascha. (2018). Ultrasonic measurements of the bulk flow field in foams. *Physical Review E*. 97. 10.1103/PhysRevE.97.013113.
Emmerich, Hannes, Schaller, Ludwig, Nauber, Richard, Knüpfer, Leon, Heitkam, Sascha, Czarske, Jürgen and Büttner, Lars. "Linear, spatio-temporally resolved ultrasound measurement of the liquid fraction distribution in froth" *tm - Technisches Messen*, vol. 88, no. 9, 2021, pp. 562-570. <https://doi.org/10.1515/teme-2021-0047>
H. Emmerich, L. Knüpfer, S. Heitkam, E. Starke, P. Trtik, L. Schaller, D. Weik, J. Czarske, "Ultrasound imaging of liquid fraction in foam", *IEEE Transactions on Instrumentation & Measurement*, 2022

EFRE/SAB Minimally invasive fiber endoscopy using laser structured waveguides

Staff: M. Kroll, R. Kuschmierz, J. Czarske

Aim: Image waveguides (CFBs) enable the realization of lensless needle endoscopes. Research is currently underway worldwide on CFB endoscopes without complex imaging optics in the measuring head. As a result, the endoscope diameter is only limited to $<500\ \mu\text{m}$ by the fiber diameter. However, strong and different aberrations (phase disturbances) occur for each CFB. Transmission of light through CFBs. With conventional endoscopes, only the light intensity can be controlled evaluated, the important phase information is lost. But this only includes 2D recordings fixed image plane and a few 1,000-100,000 pixels possible. The most studied approach for a unpixelated 3D imaging consists of measuring the aberrations of the CFB and their compensation (DOPC, digital optical phase conjugation) using programmable, digital, optical Area light modulators. This enabled impressive and relevant applications to be demonstrated will, among other things, Fluorescence microscopy, 2-photon microscopy, CARS, cell ablation, single cell rotation and - Tomography. However, the structures presented are extremely complex, expensive and sensitive compared to misalignment, so that they do not yet make their way out of the optics laboratory and into realistic ones Conditions of application have been found.

The aim is to expand commercial image waveguide components for the pure transmission of images (i.e. the light intensity) to components for the transmission of the complete light information from light intensity and light phase. For the first time, this should not be done with digital modulators, but with advances be used in optical manufacturing technology. The realized fibers are monolithic and therefore robust. They can therefore be used by a wide range of users and can be integrated into existing microscopes insert to expand their range of application from ex vitro to in vivo, for example for minimally invasive and label-free histopathology in the brain.

Period: 10/2023 – 12/2024

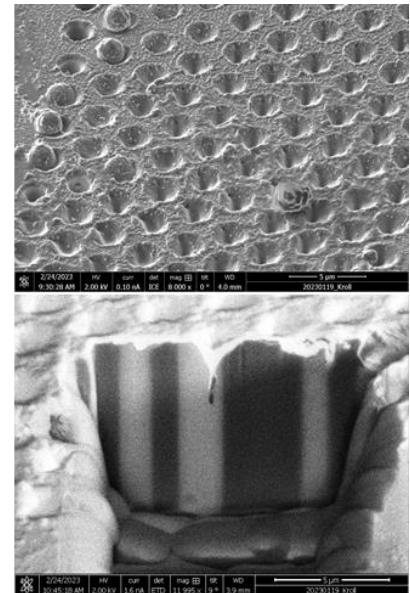
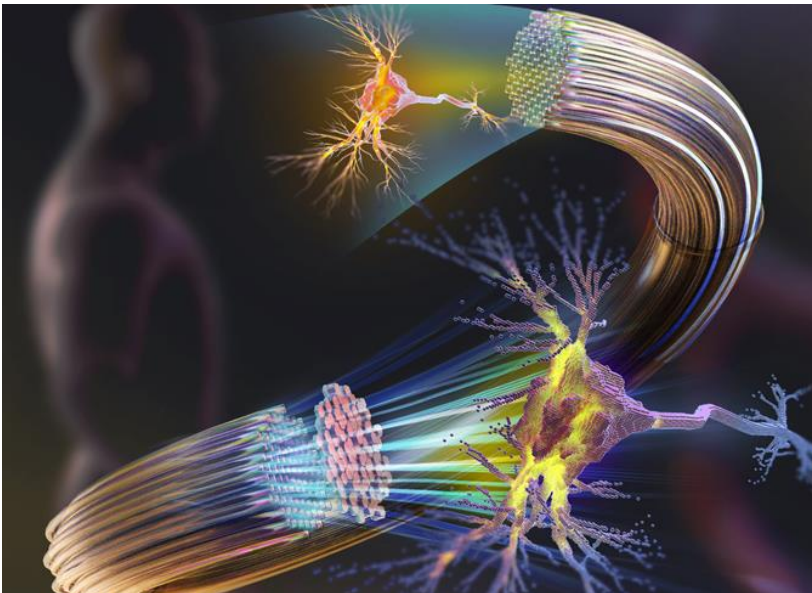

Left: Sketch of a Holographic 3D fiber bundle endoscope. A diffractive optical element is used to compensate the inherent phase scrambling of the fiber. Right: SEM image of an fiber facette after laserablation for DOE manufacturing.



Project volume based on fundamental research (DFG, etc), applied research (BMBF, SAB, AiF/ZIM) and industry projects

Dr.-Ing. Stefan Rothe

“Harnessing Disorder of Multimode Fibres to Achieve Information Security on the Physical Layer”

Abstract:

Digital communication technologies have significantly changed our lives in a very short space of time and influence it in all areas. As a result, the risk of cyberattacks is increasing rapidly and requires new methods to ensure digital security. As the backbone of the global digital infrastructure, optical communication networks represent a particularly sensitive environment. The multimode fiber represents a promising connection type here, as its spatial paths significantly increase network capacities. In this dissertation an approach is investigated with which an information-theoretically secure data exchange in optical multimode fibers is achievable by harnessing physical phenomena in the fiber channel. The idea is that the inherent disorder in the multimode fiber is exploited by a sender (Alice) in order to give a legitimate message receiver (Bob) a decisive advantage over an eavesdropper (Eve). The key is mode mixing, as well as mode-dependent losses that lead to an imbalance among distributed receivers on the fiber channel. Consequently, equalization between Alice and Bob necessarily does not apply to Eve. This technique is called physical layer security and was implemented experimentally for the first time in a multimode fiber. By measurement of the optical transmission matrix, Alice and Bob can characterize their channel for calibration and identify suitable spatial paths. For this purpose, both holographic methods and intelligent techniques based on neural networks were examined and compared. With the transmission matrix, Alice and Bob can determine a transmission-side pre-distortion to control the propagation of light through the fiber and exchange specific information. Eve, on the other hand, has to process her channel mathematically. Clever transmission strategies can exploit this asymmetry. For this purpose experiment was carried out in which Bob and Eve each received 50% of the transmitted power from a of the transmitted power from a 55-mode multimode fiber. It is shown that by means of special channel coding an information-theoretically secure data exchange can be achieved using special channel coding, in which 2 bits can be securely transmitted per channel usage, even though Eve has knowledge of all channel states. In the future, the achievable information security could be further increased by investigating the effects of induced mode mixing or time-varying transmission properties in the fiber channel. Due to fibers with D-profile fibers or external mechanical influences such as bending or twisting can provoke mode mixing or a time variance can be provoked. The results of this dissertation demonstrate for the first time the experimental feasibility of physical layer security on a multimode fiber channel and show an alternative for secure data transmission in future data transmission in optical communication networks of future infrastructures, that use spatial information paths.

Date of defense: 23.02.2023

Chairman: Prof. Dr.-Ing. Dr. h.c. Frank H. P. Fitzek
Reviewers: Prof. Dr.-Ing. habil. Jürgen Czarske, TU Dresden
Prof. Dr. Tomáš Čížmár
Prof. Dr.-Ing. Eduard A. Jorswieck
Examination: Prof. Dr.-Ing. Kambiz Jamshidi (TU Dresden)
Prof. Dr.-Ing. habil. Jürgen Czarske, TU Dresden



Dr Rothe, Prof Czarske (from left)



Fltr: Prof Fizek, Prof Jorswieck, Dr Rothe, Prof Czarske, Prof Čížmár / Dr Rothe

Dr.-Ing. Julian Lich

“Parallel and spatially resolved measurement of the deformation, damage and modal behavior of fast rotating structures by using optical diffraction gratings”

Abstract:

Due to their lightweight properties, fiber reinforced polymers (FRP) offer a high potential to increase the efficiency and performance of rotors in electric machines, turbomachines and flywheel energy storage systems. For operational safety and the development of FRP rotors, comprehensive knowledge about the complex relationship between rotational velocity, deformation, modal properties and failure behavior is necessary. However, this relationship cannot be predicted with sufficient accuracy through numerical models. In situ measurements of the gradual progress of damages and the change of modal properties as a function of the rotational velocity are essential. Although optical measurement methods can provide sufficient spatiotemporal resolution and deformation resolution, existing interferometric and photogrammetric full field techniques do not provide the necessary robustness against motion blur or additional rigid body movements. By evaluating the far field of optical diffraction gratings, surface deformations can be measured independently of motion blur as well as spatially and

temporally resolved. Thus far, such diffraction grating sensors have only been used in large optical table setups on static test specimens.

In this work, diffraction grating sensors were investigated for deformation and vibration measurement on fast rotating structures for the first time. I developed a compact and vibration robust probe head to read out the diffraction grating sensors for usage inside the limited space of a rotor test rig. Also for the first time, the rotational velocity dependent strain field was measured with uncertainties between 100 and 300 $\mu\epsilon$, spatial resolutions below 1 mm² and at surface velocities above 250 m/s. This enabled the spatially resolved measurement of the crack propagation on the surface and inside the volume of the rotor under rotational load. Additionally, the natural frequencies and the mode shapes of an FRP rotor as a function of the rotational velocity could be measured with the diffraction grating sensors. As a result, it is now possible to perform in situ measurements of the influence of gradually progressing rotational load induced damages on the modal behavior of FRP structures during rotation with a single compact measurement system. This allows for a more accurate validation and calibration of numerical models as well as for the generation of additional a priori knowledge for structural health monitoring.

Date of defense: 04.12.2023

Chairman: Prof. Dr.-Ing. habil. Uwe Marschner

Reviewers: Prof. Dr.-Ing. habil. Jürgen Walter Czarske
Prof. Dr.-Ing. habil. Dr. h.c. Alexander W. Koch

Examination: Prof. Dr.-Ing. habil. Jürgen Czarske, TU Dresden
Prof. Dr.-Ing. habil. Dr. h. c. Uwe Hampel, Helmholtz-Zentrum Dresden-Rossendorf and TU Dresden

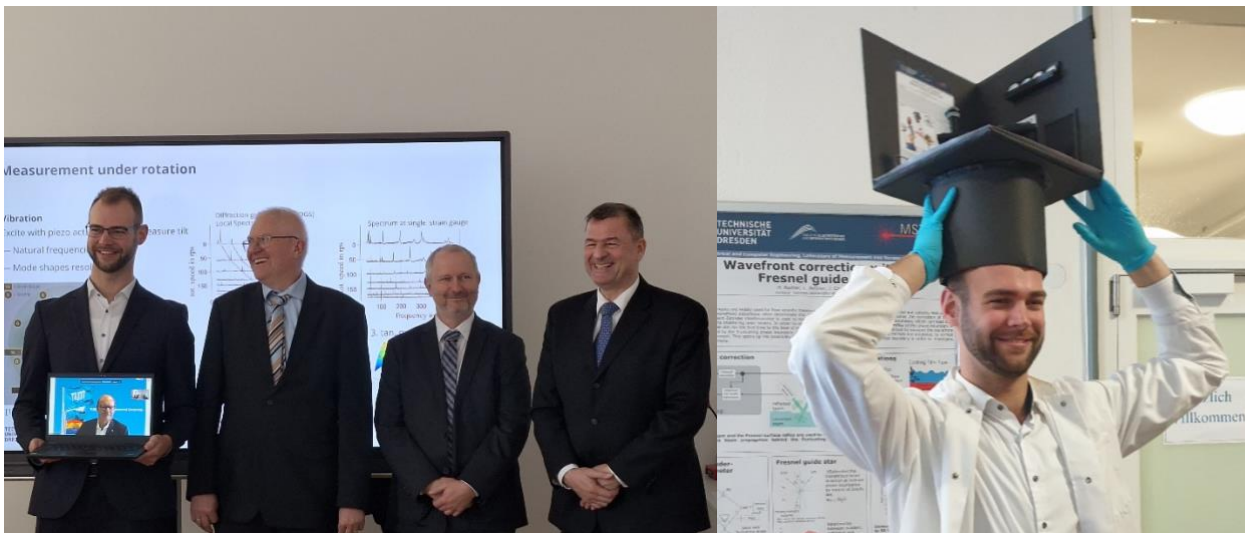

Dr Lich, Prof Czarske, Prof Hampel, Prof Marchner (from left)

Dr.-Ing. Jiawei Sun

„Learning-based Three-Dimensional Optical Cell Rotation Tomography and Quantitative Phase“

Abstract:

Optical manipulation, which uses optical force to trap, move and rotate micro-or nanoscale objects, has led to remarkable advances in biology, physics, optics, and nanotechnology. Fiber-based dual-beam traps enable optical manipulation in a lab-on-a-chip system and have emerged as a vital manipulation tool for biological cells due to their flexibility and portability. Nevertheless, optically controlled three-dimensional rotation of biological cells in a fiber-optic trap for precise optical tomography with isotropic resolution in all three dimensions remains challenging.

In this dissertation, I demonstrate a novel multi-core fiber-based dual-beam trap, allowing three-dimensional cell rotation in a program-controlled manner. To achieve this, the multi-core fiber is transformed into a remote phased array by compensating the intrinsic and temporal phase distortion using a comprehensive in situ calibration procedure. A dedicated phase retrieval algorithm and a phase encoder deep neural network are further implemented to generate the tailored phase modulation hologram for complex wavefront shaping through the multi-core fiber with high fidelity of 96.2%, enabling real-time holographic control of the optical manipulation beam. This allows optically controlled rotation of human cancer cells about arbitrary axes in three dimensions. On the other hand, conventional illumination scanning optical tomography can hardly measure the full spatial frequency due to the limited projection angle, known as the missing cone problem, resulting in low axial resolution.

The proposed fiber-optic cell rotation is implemented in optical projection tomography to overcome the problem, allowing accurate high-resolution volumetric reconstruction. Furthermore, an autonomous tomographic reconstruction workflow based on computer vision technologies and machine learning is employed for robust three-dimensional tomographic reconstruction of the rotated cell.

Moreover, due to physical limitations, lens-based fiber endoscopes are difficult to further reduce the probe size to the sub-millimeter range while maintaining imaging resolution. A novel speckle reconstruction algorithm is proposed to achieve quantitative phase imaging through the multi-core fiber with up to 1 μm lateral resolution and at least 80 nm axial sensitivity, allowing label-free three-dimensional endoscopic imaging with minimum invasiveness smaller than 0.5 mm. Deep learning is further utilized to optimize the computation speed and measurement procedure, enabling real-time phase reconstruction through the fiber. This allows online measurement of the refractive index distribution of the cell in the optical trap, which can be implemented to generate the spatially optimized trapping beam for optical manipulation.

The presented work provides innovative methods for optical manipulation, tomography, and fiber endoscopic imaging, opening new perspectives for future applications using multi-core fibers. I expect that our achievements in optical field control and imaging of multi-core fibers will expand their applications in clinical diagnostics, optogenetics, biosensors, integrated quantum photonic devices, and telecommunications.

Date of defense:	21.3.2023
Chairman:	Prof. Dr.-Ing. Kambiz Jamshidi (TU Dresden)
Reviewers:	Prof. Dr.-Ing. habil. Jürgen W. Czarske (TU Dresden) Prof. Dr. Demetri Psaltis (EPFL) Prof. Dr. Liangcai Cao (Tsinghua University)
Examination:	Prof. Dr. Stefan Diez (TU Dresden)

Prof. Dr.-Ing. habil. Jürgen W. Czarske (TU Dresden)



Dr Sun, Prof Czarske (from left) / Dr Sun



Prof Czarske, Dr Sun, Prof Jamshidi (from left)

Diploma and Master Theses

Haowen Jiang "3D fiber endoscopy using diffractive optics, structured illumination and deep learning" 2/23

Bowen Fang "An Investigation of Rayleigh-Lamb Waves based Localization of Water Droplets for Fuel Cells" 2/23

Yuan Sui "High-fidelity transmission through multimode fibers using deep learning" 5/23

Elisabeth Berkholtz "Untersuchung der linsenlosen multispektralen Bildgebung durch kohärente Faserbündel" 7/23

Anna-Lena Geppert „Adaptive Lichtfeldformung mittels Multiplane Light Conversion“ 11/23

Bin Yang „Optical diffraction tomography towards label-free 3D imaging of embryos“ 11/23

Yannick Marco Lagler "Realisierung einer biaxialen Beugungsgittersensor-Ausleseseinheit zur Dehnungsmessung an schnell drehenden Faserverbundrotoren" 11/23

Bachelor Theses

Jie Zhang "Real-time quantitative phase imaging through an ultra-thin lensless microendoscope" 1/23

Iheb Saidani "Investigation of diffractive optics for a 3D fiber endoscope with deep learning" 1/23

Yang Bowen "Simulation Platform of Optical Fiber-based Quantum Communication System" 3/23

Hannes Bischoff "Dynamische nichtlineare Schallfeldformung für Blutströmungsmessungen mittels Ultraschall-Lokalisierungsmikroskopie" 3/23

Wenting Geng "Experimental demonstration of the feasibility of quantum key distribution system" 9/23

Leon Stiffel „Charakterisierung verschiedener Bauformen kohärenter Faserbündel für endomikroskopische Anwendungen“ 10/23

Vireak Dam „Physical model based deep neural network for quantitative phase imaging through multi-core fiber“ 11/23

Konrad Ließ "Untersuchung von Algorithmen zur Auswertung von Zellbildern mit Doppel-Helix-Punktspreizfunktion für die Optogenetik" 11/23

Zhenyu Huang "Image based multi-basis fiber characterization for space division multiplexing" 12/23

Zixuan Cai "Ermittlung des Messunsicherheitsbudgets einer neuartigen Beugungsgittersensor-Ausleseseinheit durch Nutzung eines digitalen Zwillings" 11/23

Nele Kirsch „Ultrasound Imaging with a Reduced Number of Receiving Channels using an External Angle-dependent Resonator“ 11/23

Malte Weigelt „Untersuchung der akustischen Auswirkung von Schallkanal-geometrien für luftgekoppelte Phased-Arrays zur bildgebenden Messung von Flotationsschäumen“ 12/23

Jonas Schönerstedt "In Silico Untersuchung der Fernfeldbildung durch Faserbündel unter Berücksichtigung der Dispersion bei breitbandigen Lichtquellen" 12/23

Fang Lyu „Ultraschallbasierte Messung des Gasgehaltes eines Mehrphasen-gemisches durch Nutzung eines Multiprocessor System-On-A-Chip zur Systemintegration“ 12/23

Rongfei Hou "Deep learning-based fiber bundle imaging using superimposition" 12/23

Master and Bachelor Thesis

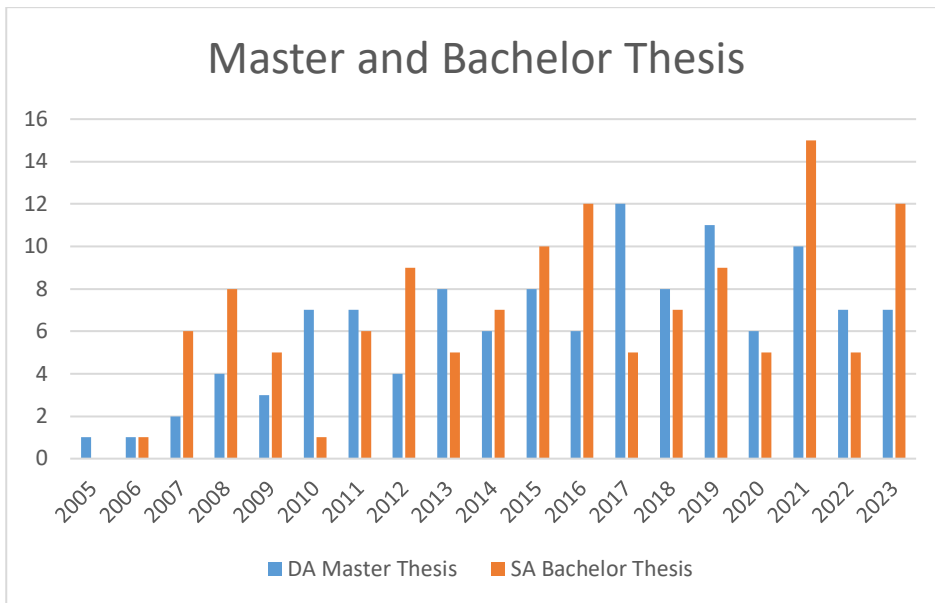

Total in 19 years: 128 Bachelor Theses (SA) and 118 Master Theses (DA)

PUBLICATIONS AND TALKS

SCI-Publications in journals with peer review process

Jiawei Sun, Juergen W. Czarske, "Compressive holographic sensing simplifies quantitative phase imaging", *Light: Science & Applications*, 2023

S Rothe, KL Besser, D Krause, R Kuschmierz, N Koukourakis, Eduard Jorswieck, JW Czarske, "Securing Data in Multimode Fibers by Exploiting Mode-Dependent Light Propagation Effects", *Research*, 2023

D Pohle, F A Barbosa, F F Ferreira, JW Czarske, S Rothe, "Intelligent self-calibration tool for adaptive few-mode fiber multiplexers using multiplane light conversion", *JEOS*, (2023)

H. Emmerich, L. Knüpfer, S. Heitkam, E. Starke, P. Trtik, L. Schaller, D. Weik, JW Czarske, "Ultrasound imaging of liquid fraction in foam," *IEEE Transactions on Instrumentation and Measurement* 72 (2023), 6500211.

Jiawei Sun, Bin Yang, Nektarios Koukourakis, Jochen Guck, and Juergen W. Czarske, "AI-driven projection tomography with multicore fibre-optic cell rotation", *Nature Communications*, 2023

Zhang Q, Charania S, Rothe S, Koukourakis N, Neumann N, Plettemeier D, Czarske JW, "Multimode Optical Interconnects on Silicon Interposer Enable Confidential Hardware-to-Hardware Communication". *Sensors*. 2023; 23(13):6076.

K. Schmidt, N. Guo, W. Wang, J. Czarske, and N. Koukourakis, "Chromatic aberration correction employing reinforcement learning," *Opt. Express* 31, 16133-16147 (2023)

Wenjie Wang, Katharina Schmidt, Matthias C. Wapler, Ulrike Wallrabe, Juergen W. Czarske, and Nektarios Koukourakis, "Fully refractive telecentric f-theta microscope based on adaptive elements for 3D raster scanning of biological tissues", *Optics Express*, 2023

Z. Dou, B. Fang, L. Tropic, H. Hoster, H. Schmidt, J. Czarske and D. Weik, "A Water Monitoring System for Proton Exchange Membrane Fuel cells Based on Ultrasonic Lamb Waves: An Ex-situ Proof of Concept", *IEEE Transactions on Instrumentation and Measurement* 72 (2023), 9601112.

R. Maestri, S. Radhakrishnakumar, F. Bürkle, W. Ding, L. Büttner, J. Czarske, U. Hampel and G. Lecrivain, "Equilibrium Taylor bubble in a narrow vertical tube with constriction", submitted to *Physics of Fluids*, 2023.

Jiawei Sun, Jie Zhang, Nektarios Koukourakis, and Juergen W. Czarske, " Calibration-free quantitative phase imaging in multi-core fiber endoscopes using end-to-end deep learning", *Optics Letters*, 2023

Invited talks at conferences (with proceedings)

Stefan Rothe, Karl-Ludwig Besser, David Krause, Dennis Pohle, Robert Kuschmierz, Nektarios Koukourakis, Eduard Jorswieck, Jürgen W. Czarske, Achieving Information Security in Spatially Multiplexed Communication Systems by Harnessing Disorder of Multimode Fibres. In 2023 23rd International Conference on Transparent Optical Networks (ICTON), invited by Norbert Hanik (TU Munich), 2023

JW Czarske, N Koukourakis, S Rothe, F Wagner, MO Karl, "Investigation of neurodegeneration in the human organoid retina with transmission matrix measurements", 30 January 2023 (Conference Presentation), Adaptive Optics and Wavefront Control for Biological Systems IX, PC123880E, Part of SPIE BiOS, San Francisco, USA (invited talk), 2023

J. Sun, J Czarske, “Smart multi-core fiber endoscope for light field control and detection”, 5th International Forum of Advanced Photonics for Young Scientists, Zhejiang University, 2023 (invited talk)

J Czarske, E Scharf, R Kuschmierz, “3D printed holograms onside of the multicore fiber facet for lensless 3D imaging with keyhole access”, ITO Colloquium, Stuttgart, 24 March 2023 (invited talk)

J Czarske, R Kuschmierz, “Novel lensless multicore fiber endoscopy using femtosecond laser- based 3D printed holograms and deep learning for biomedicine”, invited by Robert Alfano (New York City University), Fort Lauderdale, Florida, US, LOPS Conference, June 2023 (invited talk)

J Czarske, N Koukourakis, J. Sun, “Multicore fiber endoscopy for 3D rotation of cancer cells – QPI Tomography of Cells”, SPIE Metrology Conference, June 2023, Munich (invited talk)

Juergen W. Czarske, T Glosemeyer, J Lich, R Kuschmierz, „Computational Lensless Multicore Fiber Endoscopy using Diffuser and Physics-Informed Deep Learning (Keynote)”, Optics Frontier: The 14th International Conference on Information Optics and Photonics, Xi’an, China, 7-10 August 2023

Jiawei Sun, N Koukourakis, JW Czarske “Computational multicore fiber-optic cell rotation tomography with isotropic 3D resolution (Invited)”, Optics Frontier:The 14th International Conference on Information Optics and Photonics, Xi’an, China, 7-10 August 2023

T. Wang, J. Dremel, J. Wu, O. Uckermann, R. Galli, I. Eyüpoglu, J. Czarske, R. Kuschmierz, “Learning-based lensless fiber bundle imaging with real-time resolution enhancement for biomedicine”, SPIE Optics + Photonics Conference 2023, San Diego, USA, August 2023 (invited talk)

Juergen Czarske (TU Dresden, Germany), R Kuschmierz, “Novel lensless endoscopic imaging using multicore fibers and physics-informed deep learning for biomedicine”, Keynote, Light Conference Week, Light Conference, Academic League, Prize Ceremony, Exhibition, Changchun, China August 2023 (invited talk)

Nektarios Koukourakis, Jiawei Sun, Juergen W. Czarske*, “Optical diffraction tomography based on AI-driven adaptive optical cell-rotation”, 22 August 2023, invited by Aydogan Ozcan and Giovanni Volpe, SPIE Optics + Photonics Conference 2023, San Diego, USA, August 2023 (invited talk)

Robert Kuschmierz, “Inverting the complex valued transfer function of imaging waveguides for lensless endoscopy”, Photonics Global Conference, Stockholm, Sweden, August 2023 (invited)

L. Buettner, C. Bilsing, Z. Gao, J. Czarske, “Closed-Loop and Neural Network Aberration Correction Schemes for Correlation-Based Laser Velocimetry”, 16th International Conference on Correlation Optics, 18.–21.09.2023, Chernivtsi/Ukraine (invited)

Martin Kroll, E. Scharf, R. Stefan, M. Steinke, J. Czarske, R. Kuschmierz, „Novel lensless fiber endoscopy by additive and subtractive femtosecond laser based manufacturing for biomedicine”, Optics and Photonics Africa, 05.11.-10.11.2023, White River, South Africa (invited)

Juergen Czarske, J Sun, N Koukourakis, Computational Fiber-optical Communication and Sensing exploiting AI, (invited by ChaoYang Lu), 2023, International Conference on Quantum Photonics (QPhotonIX 2023), November 24-27, 2023 in Jinhua, China.

Qian Zhang, Y Sui, J Czarske, “Intelligent IntegratedFiberOptic Communication and Sensing” Invited by ChaoYang Lu, International Conference on Quantum Photonics (QPhotonIX 2023), November 24-27, 2023 in Jinhua, China.

Jiawei Sun, J Czarske, N Koukourakis, Smart Multi-core Fiber Endoscopy for Optical Manipulation and 3D Imaging, Invited by ChaoYang Lu, International Conference on Quantum Photonics (QPhotonIX 2023), November 24-27, 2023 in Jinhua, China.

Invited talks (at seminars/workshops)

J Czarske, R Kuschmierz, N Koukourakis, "Novel lensless multicore fiber endoscopy for biomedicine", SPIE-OPTICA Student Chapter of University of California at Berkeley, 28 January 2023 (invited talk)

Juergen Czarske, R Kuschmierz, N Koukourakis, S Rothe, "Advancing multicore fiber endoscopy and multimode fiber communication using deep learning and modern holography", Orlando, Creol, June 2023 (invited talk at the SPIE-OPTICA Student Chapter)

Juergen Czarske, E Scharf, J Dremel, T Glosemeyer, R Kuschmierz, „Minimally invasive lensless multicore fiber endoscopy using 3D-printed holograms and deep learning for biomedicine”, Tucson, University of Arizona, Seminar of Wyant College of Optical Sciences, 3 February 2023 (invited talk)

Juergen W. Czarske, Robert Kuschmierz, D. Pohle, X. Zhan, „Multicore and Multimode Fiber-based Lensless Imaging for Breakthroughs in Biomedicine, Communication and Quantum Key Distribution”, Institute for Photonics Chips, Invited by Distinguished Professor Min Gu, Executive Chancellor of the University Council at University of Shanghai for Science and Technology (USST), Shanghai, China, 9 August 2023

Juergen W. Czarske, T Glosemeyer, J Lich, J Sun, R Kuschmierz, N Koukourakis, „Computational Lensless Fiber Endoscopy using AI/ML/DNN and Digital Holography”, Shanghai AI Lab, Department of Artificial Intelligence, Optics and Electronics, Shanghai, China, 10 August 2023

J Czarske, Q Zhan, J Sun, "Computational lensless multicore and multimode fiber techniques using deep learning and wavefront shaping", invited by Prof Guohai Situ, Shanghai Institute of Optics and Fine Mechanics, 390 Qinghe Road, Shanghai 201800, China, 11 August 2023 (award: The 70th Qinghe Seminar of Chinese Academy of Sciences)

J Czarske, R Kuschmierz, N Koukourakis, J Sun, "Lensless multicore fiber endoscopy using deep learning, optical diffraction tomography for biomedicine", Peking University, Beijing, China, 15 August 2023

J Czarske, R Kuschmierz, N Koukourakis, J Sun, "Computational lensless multicore fiber endoscopy using deep holography for biomedicine", invited by Prof L Cao, Tsinghua University, Beijing, China, 16 August 2023 (honor of certificate for appreciation for cooperation and student exchange)

J Czarske, R Kuschmierz, L Buettner, N Koukourakis, J Sun, "Computational imaging using adaptive optics, deep neural networks and entangled photons for biomedicine and communication", invited by Pan Feng, Beihang University, Beijing, China, 17 August 2023

Q Zhang, J Czarske, "AI-based Demultiplexing for Multimode Fiber Communication and Quantum Technology", Chengdu, November 28, 2023 (invited by Zeyu Gao)

J. Czarske, Q Zhang, T Glosemeyer, N Koukourakis, L Buettner, "Computational lensless imaging using AI, digital holography, adaptive optics and wavefront shaping", Chengdu, November 28, 2023 (invited by Zeyu Gao)

Juergen Czarske, Q Zhang, D Pohle, „Computational Multimode Fiber Imaging and Communication”, Tucson, University of Arizona, Computational Imaging Colloquium, Wyant College of Optical Sciences, 17 November 2023 (invited talk)

J. Czarske, Q Zhang, T Glosemeyer, R Kuschmierz, N Koukourakis, "Computational lensless multicore fiber endoscopy using deep learning and Quantum Technology of Second Generation", invited by Prof Guohai Situ, Shanghai Institute of Optics and Fine Mechanics, 390 Qinghe Road, Shanghai 201800, China, 30 Nov 2023

J Czarske, D Pohle, T Glosemeyer, R Kuschmierz, N Koukourakis, "AI, Machine Learning and Deep Neural Networks in Optics for Sensing and Communication", invited by Dr Wang and Dr Sun, Shanghai AI Lab, Department of Artificial Intelligence, Shanghai, 30 Nov 2023 (Honorary Speaker Award for conducting the 23rd StarRiver Talk of Shanghai AI Lab)

Q Zhang, J Czarske, "Intelligent Digital Demultiplexer for Structured Light in Multimode Fibers", Shanghai AI Lab, Department of Artificial Intelligence, Shanghai, 30 Nov 2023 (invited by Dr Wang and Dr Sun)

International conferences (reviewed)

Dr. Jiawei Sun, N Koukourakis, JW Czarske (TU Dresden, German) (Oral) Title: "Physics-informed deep learning and multicore fibers towards high-resolution cell tomography", Light Conference Week, Light Conference, Academic League, Prize Ceremony, Exhibition, Changchun, China, August 2023

Stefan Rothe, David Krause, Qian Zhang, Dennis Pohle, Nektarios Koukourakis and Jürgen W. Czarske, "Learning to control the complex light propagation through few-mode fiber without a reference wave", CLEO San Jose // 8th May 2023

Jiawei Sun, Nektarios Koukourakis, Juergen W. Czarske*, "3D cell rotation in multicore fiber-based optical diffraction tomography with isotropic resolution using deep learning", SPIE Optics and Photonics, San Diego, USA, 22 August 2023

Elias Scharf, Martin Kroll, Jürgen Czarske*, Robert Kuschmierz, "Additive and subtractive manufacturing of multi-core fibers for lensless endoscopy," LIM 2023 Munich, WLT, 2023

Jiawei Sun*, Nektarios Koukourakis and Jürgen W. Czarske, "Learning-based quantitative phase imaging through an ultra-thin lens-free fiber microendoscope", SPIE Photonics West, 2023 (Oral)

Willi G. Mantei, Jonas Wiedenmann, Benedikt Stender, Elias Scharf, Robert Kuschmierz, Jürgen Czarske, Lensless holographic endoscopes realized with direct laser writing, 2 March 2023 • 11:10 AM - 11:30 AM PST | Convention Center, Room 211B, 12497-38

R Kuschmierz, E Scharf, J Dremel, K Zolnacz, R Stephan, M Steinke, ..., J Czarske, 3D micro-endoscopy enabled by 2-photon polymerization and advanced fiber design (Conference Presentation), Adaptive Optics and Wavefront Control for Biological Systems IX, PC123880C, 2023

J Sun, N Koukourakis, JW Czarske, Image quality enhancement for ultra-thin lensless multi-core fiber phase endoscopes, Quantitative Phase Imaging IX 12389, 16-21, 2023

T Glosemeyer, J Lich, R Kuschmierz, J Czarske, Step-by-step transfer function reversal for single-shot 3D fiber endoscopy using a diffuser, Three-Dimensional and Multidimensional Microscopy: Image Acquisition and ..., SPIE, San Francisco (2023)

N Koukourakis, L Liebig, JW Czarske, Impulsive stimulated Brillouin microscopy for high-speed biomedical diagnostics (Conference Presentation), Optical Elastography and Tissue Biomechanics X, PC1238109
2023

R Stephan, E Scharf, K Zolnacz, K Hausmann, M Ließmann, L Kötters, ..., J Czarske, Aperiodic multi-core fibers for lens-less endoscopy, Optical Fibers and Sensors for Medical Diagnostics, Treatment and ..., San Francisco, 2023

J Dremel, E Scharf, T Wang, S Richter, O Uckermann, W Polanski, I Eyüpoglu, J Czarske, R Kuschmierz; Autofluorescence based in vivo endoscopy for brain tumour diagnosis; SPIE ECBO 2023

J Gürtler, S Tasmany, R Kuschmierz, J Woisetschläger, J Czarske, Neural network based tomographic reconstruction of high-speed interferometric and Schlieren image data for density and velocity detection, SPIE Optical Metrology 2023, Munich

D Pohle, F A Barbosa, F F Ferreira, J Czarske, S Rothe, Intelligent self-calibration tool for digital few-mode fiber multiplexers based on multiplane light conversion, SPIE Digital Optical Technologies 2023, Munich

F Schmieder, L Büttner, W Derks, O Bergmann, J Czarske, Simultaneous optogenetic stimulation and inhibition using fast ferroelectric spatial light modulators and digital holograms; SPIE Digital Optical Technologies 2023, Munich

E Jorswieck, PH Lin, P, Nowitzki, D Pohle, J Czarske, "Secret Key Generation for Physical Layer Security Exploiting Multi-Mode Fiber Transmission", IEEE international Workshop on Information Forensics and Security 2023, Montpellier (submitted)

K. Schmidt, N. Guo, W. Wang, J. Czarske, N. Koukourakis, „Chromatic aberration correction using reinforcement learning“, SPIE Optics+Photonics 2023, Emerging toptics in artificial intelligence, San Diego, 2023

Qian Zhang, Yuan Sui, Dennis Pohle, Nektarios Koukourakis, Jürgen W. Czarske, Stefan Rothe, TU Dresden (Germany), "Reference-less phase retrieval of multimode fibers using a deep neural network" 23 August 2023, Conv. Ctr. Room 6C, 12655-44, SPIE Optics+Photonics 2023, Emerging toptics in artificial intelligence, San Diego, 2023

Clemens Bilsing, Lars Büttner, Sebastian Burgmann, Bergische Univ. Wuppertalm Jürgen W. Czarske, "High-speed 3D particle tracking with dynamic aberration correction using a Fresnel guide star", 21 August 2023, Conv. Ctr. Room 6E, SPIE Optics+Photonics 2023, Unconventional Imaging, Sensing, and Adaptive Optics, San Diego, 2023

J. Lich, T. Wollmann, R. Kuschmierz, M. Gude, J. Czarske, „Optical sensor for localized damage detection and modal analysis on fast rotating fiber reinforced polymer structures“, SPIE Optical Metrology 2023, Munich

Elias Scharf, Ronja Stephan, Kinga Zolnacz, Michale Steinke, Robert Kuschmierz, Jürgen Czarske, "Lensless Single-Shot Endoscopy With Needle-Thin Multicore Fiber Bundles Enabled by 2PP 3D Printing on the Fiber Tip", Optica Imaging Congress, Boston, 2023

Z. Dou, L. Tropic, H. Hoster, H. Schmidt, J. Czarske, D. Weik, „Advanced Ultrasonic Diagnostic Technology Towards Green Hydrogen Energy Systems“, 2023 IEEE International Ultrasonics Symposium (IUS), Montreal, Canada, Sep. 2023, Student Paper Award Finalist and mentioned conference highlight.

D. Weik, Z. Dou, H. Emmerich, J. Czarske, „Dual Channel Ultrasound Imaging Using a Time Reversal Virtual Array and an External Angle-Dependent Resonator – EAR“, 2023 IEEE International Ultrasonics Symposium (IUS), Montreal, Canada, Sep. 2023

H. Emmerich, L. Knüpfer, S. Heitkam, K. Eckert, D. Weik, J. Czarske, „The metrological challenge of monitoring froth processes – a numerical approach to model sound propagation in foam“, International Congress on Ultrasonics (ICU), Beijing, China, Sep. 2023

Z. Dou, L. Tropic, H. Hoster, H. Schmidt, J. Czarske, D. Weik, „Ultrasonic lamb waves based high-resolution droplet microscopy for proton exchange membrane fuel cells applications“, International Congress on Ultrasonics (ICU), Beijing, China, Sep. 2023

Tom Glosemeyer, Julian Lich, Robert Kuszmierz, Jürgen Czarske, “Diffuser-based fiber endoscopy for single-shot 3D fluorescence imaging”, EOSAM, Dijon, France, 14th September 2023

Qian Zhang, Yuan Sui, Stefan Rothe, Jürgen W. Czarske, “Physics-informed mode decomposition neural network for structured light in multimode fibers”, 2023 IEEE Photonics Conference (IPC), Optical AI and Computational Photonics I, MG1: Photonic Neural Networks, 13 November 2023, Orlando, 2023

D. Pohle, F. A. Barbosa, F. M. Ferreira,, S. Rothe, Juergen Czarske*, Digital few-mode fiber multiplexer using multiplane light conversion, 2023 IEEE Photonics Conference (IPC), TuC3: SDM and Multiband Transmission, 14 November 2023, Orlando, 2023

Q. Zhan, Yuan Sui, S. Rothe, Juergen Czarske*, Learning to demultiplex the superposition of spatial modes in multimode fiber using physics-informed deep learning, Frontiers in Optics + Laser Science - OPTICA, FiO, FTu1D.3, Advancement in Optical Fibers, October 2023, Tacoma/Seattle

D. Pohle, F. A. Barbosa, F. M. Ferreira,, S. Rothe, Juergen Czarske*, Smart Few-Mode Fiber Multiplexer using Multiplane Light Conversion, Frontiers in Optics + Laser Science FiO - OPTICA, FM1C.3, Optical Instrumentation, October 2023, Tacoma/Seattle

National conferences (reviewed) and Talks (at seminars/workshops)

D. Pohle, S. Rothe, F. A. Barbosa, F. M. Ferreira, J. Czarske, „Novel architectures for quantum communication by Smart Adaptive All-Optical Mode Multiplexers“, QR.X Workshop, Bonn, March 2023

A. Geppert, D. Pohle, J. Czarske, S. Rothe, „Digitale optische Modenprogrammierung für räumliches Multiplexing von Quantenzuständen“, 124. DGaO Jahrestagung, Berlin, Juni 2023

F. Bürkle, G. Lecrivain, R. Maestri, J. Czarske, L. Büttner, “Investigation of the flow inside a Taylor bubble in a tube with a short constriction”, 19th Multiphase Flow Conference, 2023

G. Hartl, F. Schmieder, L. Büttner, J. Czarske, „Optogenetics Research with Human Stem Cell-Derived Cardiomyocytes and Neural Networks”, PoL Bio-Image Analysis Symposium, August 2023, Poster

J. Dremel, S. Richter, T. Wang, G. Schackert, I. Eyüpoglu, J. Czarske, W. Polanski, O. Uckermann, R. Kuszmierz, „Brain tumors in the spotlight“, Ai in Medicine 2023, October, 2023

E. Scharf, R. Stephan, M. Steinke, R. Kuszmierz, J.Czarske, „Nadelförmiges linsenloses holografisches Endoskop – HoloScope“, F.O.M.-Konferenz 2023, online (Berlin), Nov. 2023

F. Bürkle, A. Bashkatov, A. Babich, X. Yang, K. Eckert, J. Czarske, L. Büttner, „ Measurement of the internal flow in hydrogen bubbles using a model-based aberration correction“, Beitrag 12, 30. Fachtagung “Experimentelle Strömungsmechanik”, München, 5.-7.9.2023

Book Chapters and Books

Stefan Rothe, “Harnessing Disorder of Multimode Fibres to Achieve Information Security on the Physical Layer”, Band: 20, Reihe: Dresdner Berichte zur Messsystemtechnik, ISBN 978-3-8440-9123-6, Englisch, Paperback, 198 Seiten, 2023

Jiawei Sun, “Learning-based Three-Dimensional Optical Cell Rotation Tomography and Quantitative Phase Imaging Using Multi-Core Fibers”, Band: 19, Reihe: Dresdner Berichte zur Messsystemtechnik, ISBN 978-3-8440-9052-9, Englisch, Paperback, 158 Seiten, 2023

Florian Bürkle, „Untersuchung interferometrischer Messtechniken zur hochauflösenden Geschwindigkeits- und Temperaturprofilmessung für Fluide in Brennstoffzellen“, Band: 18, Reihe: Dresdner Berichte zur Messsystemtechnik, ISBN 978-3-8440-8951-6, Deutsch, Paperback, 128 Seiten, 2023

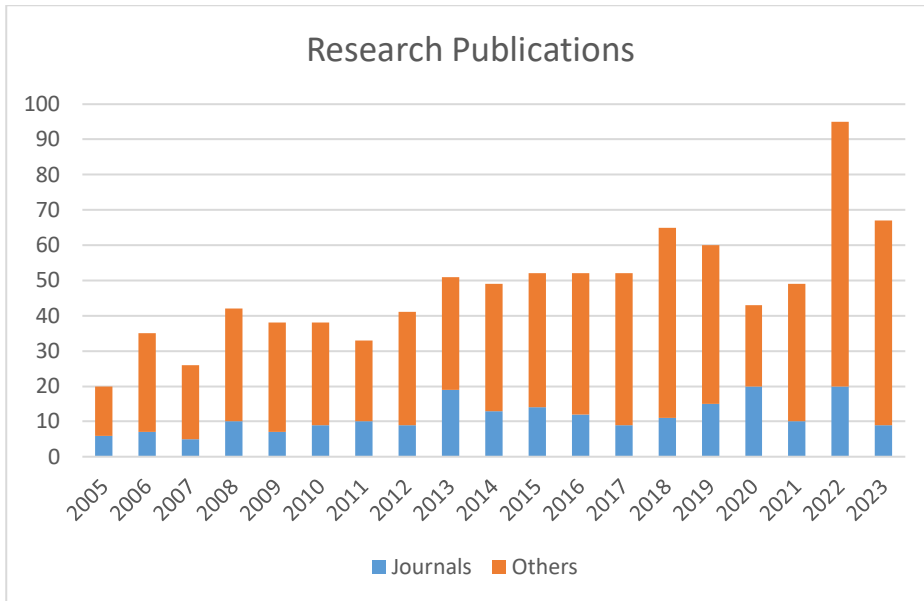

ACTIVITIES

Chair of MST, Prof. Czarske:

Program committees include (TPC, technical program committee):

TPC of OPTO / Sensor Conferences (AMA), Nürnberg

TPC of ITG / GMA-Fachtagung „Sensoren und Messsysteme“, Nürnberg

IMEKO Symp. Laser Metr. For Precision Meas. And Inspection in Industry

SPIE Photonics Europe, Photonics, Optics, Lasers, Micro- and Nanotechn., Optical Micro- and Nanometrology, Unconventional Imaging; Strasbourg, France

SPIE Photonics West, San Francisco

Conference of DGaO, Deutsche Gesellschaft für angewandte Optik e.V.

OSA conference on Optical Sensors, Barcelona, Spain

International Symposium on Optomechatronic Technologies, Seattle, USA

SPIE Opt. Meas. Syst. For Industr. Inspection,

icOPEN, Singapore,

European Optical Society Conferences

Organization of a conference in Dresden on all stages (financial issues, management with the agencies, advertisement for the congress, invitations with quality check points, generation of the program, orga for the venue, etc.): World Congress of Optics and Photonics of International Commission for Optics (ICO) and Optics Within Life Sciences (OWLS), Theme: Advancing Society with Light, ICO-25-OWLS-16-Dresden-Germany-5-9-Sep-2022, www.ico25.org

Co-chair of DIGITAL optical technologies, Munich, SPIE

Memberships include:

Fellow of International Society of Optical Engineering (SPIE), Washington USA

Fellow of European Optical Society (EOS), Finland

Fellow of Optical Society of America (OSA/Optica), DC USA

Fellow of IET (former IEE), London, UK

Fellow of IoP, London, UK

Society for Imaging Science and Technology, London

Member of Arbeitskreis der Hochschullehrer für Messtechnik eV. (AHMT);

Senior Member of IEEE;

Forschungsgesellschaft f. Messtechnik, Sensorik u. Medizintechnik e. V. (fms);

Member of Dechema

Board of Trustees of GALA (German Association of Laser Anemometry);

German Physical Society (DPG);

Verband der Elektrotechnik, Elektronik und Informationstechnik (VDE);

Board of German Society of Applied Optics (DGaO);

Fraunhofer IPMS: Curator

Member of Fraunhofer Society

Member of Excellence Cluster Physics of Life-PoL

Member of EKfZ for Digital Health

Elected Member of SAW – Saxon Academy of Sciences

Elected Vice President of ICO – International Commission for Optics, Paris, France and Miami, USA

Service as Reviewer - Granting Agencies (partial list)

German Research Foundation (DFG: Individual Grants Programs, Priority Programs, Research Training Groups, Collaborative Research Centers, Core Facilities, Research Units, etc.), BMBF, AIF, The Netherlands Organization for Scientific Research (NWO), Israel Science Foundation (ISF), King Faisal Foundation Saudi Arabia, National Science Foundation US

Service as Consultant and Advisor includes

Member Program Committee Sensor and Measurement Systems; Member Review Board System Engineering DFG (2012-2020); Member of review committee at Nanyang Technological University Singapore

Review of journal contributions (peer-review):

“Measurement Science and Technology”, “Applied Optics”, „Opt. Engineering“, „Pure Opt.“, „Opt. Letters”, “Opt. Express”, “Opt. Communications”, “Experiments in Fluids”, “Journal of Physics D: Applied Physics”, “Optics and Lasers in Engineering”, “Review of Scientific Instruments”, “Mechanical Systems and Signal Processing”, “Journal of the Optical Society of America A”, “IEEE Transactions on Instrumentation & Measurement”, „Flow Measurement and Instrumentation“, etc.

Member of the Editorial Board:

tm - Technisches Messen, Open Journal of Fluid Dynamics, Journal of the European Optical Society - Rapid publications, LAM of Nature Publishing, Applied Sciences, Photonics, etc.

“Akademische Selbstverwaltung” of TUD:

Member of the Senate, the Faculty Council, the PhD committee and the Study committee of the Faculty of Electrical Engineering and Information Technology, etc.

Co-opted Professor for Physics

Group Leaders

Dr. Lars Büttner:

- Studied Physics at Clausthal University of Technology, received a Ph.D. degree at Leibniz University Hanover
- Member of the German Association for Laser Anemometry – GALA e. V., the German Physical Society – DPG e.V., OPTICA (formerly OSA – The Optical Society)
- Supporting an MST key topic on computational metrology, especially the translation research in cooperation with renewable energy systems and magnetohydrodynamics.
- Reviewer activities include journals (Flow Measurement and Instrumentation, Optics and Lasers in Engineering, Optics and Laser Technology) and project proposals
- Co-Recipient of the 2008 Berthold Leibinger Innovation Award (3. Prize)
- Guest Editor of mdpi Appl. Sci. 2022 Special Issue "Computational Ultrasound Imaging and Applications"

Dr. Nektarios Koukourakis:

- Member of OPTICA (formerly OSA – The Optical Society), SPIE, DGaO, German Physical Society (DPG)
- Supporting an MST key topic on computational adaptive microscopy, translation research in cooperation with biomedical engineering, nanotechnology and microsystem engineering.
- Guest Editor of the journal Applied Sciences.
- Reviewer activities include journals such as Optics Express, Optics Letters, Applied Optics, Applied Physics Letters, Applied Physics B, Optics Communications
- Awarded by the OSA, Florida, USA
- Several invited talks

Dr. Robert Kuschmierz:

- Studied Mechatronics and received his Ph.D. in electrical engineering at TU Dresden
- Member of the German Physical Society (DPG), The Association of German Engineers (VDI), SPIE & OPTICA
- Current research interests include interferometry, holography and wavefront shaping for measurements at rotating machinery, sound-flow interaction, flame characterization and for lensless endoscopy
- Guest Editor of the journal Applied Sciences.
- Reviewer activities include Optics Express, Light: advanced manufacturing, Nature Communications, LSA
- Received awards for his Ph.D. thesis on *interferometric in-process metrology* by company SICK and Siegfried Werth Foundation and supervised multiple award-winning students in the field of computational endoscopy

Dipl.-Ing. David Weik

- Studied electrical engineering at the TU Dresden and former staff member of the biomedical engineering group at the Fraunhofer Institute for Machine Tools and Forming Technology
- Member of IEEE Ultrasonics, Ferroelectrics and Frequency Control Society (UFFC)
- Current research interests include adaptive ultrasonic imaging for opaque fluids, aberration correction and super-resolution imaging in technology and biomedical engineering
- Cooperation partner of the Sick Engineering GmbH, the Helmholtz-Zentrum Dresden-Rossendorf and the hydrogen and fuel cell center ZBT GmbH

Prof Juergen Czarske

- Supporting an MST key topic on multimode fiber imaging and communication: quantum technology of second generation, physical layer security for multimode fiber communication and sensing, internet of things, topological quantum states, entangled photon teleportation, optical diffractive neural networks (AI-based optical computer-More than Moore), physics-informed neural networks for decomposition of modes, multiplane light conversion for multiplexing of multimode fibers, photonic lantern, data security for the backbone of internet

PARTNERS (SELECTION)

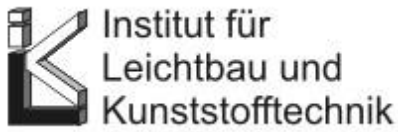

Laboratory of Measurement and Sensor System Technique (MST) / Czarske Lab

Head: Prof. Dr.-Ing. habil. Juergen Czarske

Secretary: Mrs. Cathleen John

Mail address: Technische Universität Dresden
Fakultät Elektrotechnik und Informationstechnik
Professur für Mess- und Sensorsystemtechnik
01062 Dresden

Visitor address: Helmholtzstraße 18
Barkhausenbau, room 22

Phone: +49 (0)351 463 39808; - 37657

Fax: +49 (0)351 463 37716

E-Mail: grp-mst-sekretariat@mx.tu-dresden.de

Internet: <https://tu-dresden.de/ing/elektrotechnik/iee/mst/>
<http://lasermetrology.de>



DRESDEN
concept
Exzellenz aus
Wissenschaft
und Kultur