

# Classification of Waste-to-energy Plants in Terms of Energy Recovery

## Kurzfassung

### Einordnung von Müllverbrennungs- anlagen im Hinblick auf die energetische Verwertung

Bei der energetischen Bewertung von Müllverbrennungsanlagen gibt es u.a. zwei unterschiedliche Aufgaben:

- I. Die energetische Effizienz einer Anlage aus technischer Sicht zu ermitteln.
- II. Die energetische Verwertung gegenüber der Beseitigung aus politisch/juristischer Sicht festzulegen.

Für die erste Aufgabe wird auf die bekannten und bewährten ingenieurtechnischen Grundlagen (technische Sicht) [z. B. 1, 2] zurückgegriffen.

Die Festlegung bei der zweiten Aufgabe fußt auf einer politisch gewollten Ordnungsfunktion (politische Sicht) [3].

In der jüngsten Vergangenheit hat es zum Teil heftige Diskussionen darüber gegeben, wann einer Müllverbrennungsanlage aus politisch/juristischer Sicht der Status einer energetischen Verwertung zuzuordnen ist oder nicht. Dabei sind die Irritationen u.a. auch dadurch entstanden, dass beide vorgenannte Betrachtungsweisen und damit zusammenhängende Argumente miteinander vermischt wurden. Trennt man beide Sichtweisen sorgfältig, ist auch insgesamt ein Weg vorgezeichnet, wie „das Problem zur Einordnung“ zu beheben ist. Dazu soll im Folgenden ein Beitrag geliefert werden.

Es werden beide Betrachtungsweisen erläutert und es kann ein Resümee wie folgt gezogen werden:

## Authors

**Prof. Dr.-Ing. Michael Beckmann**  
 Bauhaus-Universität Weimar  
 Weimar/Germany.

**Ferdinand Kleppmann**  
 President Confederation of  
 European Waste-to-Energy Plants (CEWEP)  
 Brussels/Belgium.

**Johannes J.E. Martin**  
 Managing Director  
 Martin GmbH für Umwelt- und  
 Energietechnik, München/Germany.

**Prof. Dr.-Ing. Reinhard Scholz**  
 Technische Universität Clausthal  
 Clausthal-Zellerfeld/Germany.

**Prof. Dr.-Ing. Helmut Seifert,**  
 Forschungszentrum Karlsruhe GmbH  
 Karlsruhe/Germany.

1. Die VDI-Richtlinie 3460 [2] basiert auf bekannten und bewährten ingenieurtechnischen Kenntnissen und ist damit die Grundlage der Bewertung der Energieeffizienz von Müllverbrennungsanlagen, insbesondere vor dem Hintergrund der Optimierung.
2. Die R1-Funktion [3] hat eine politische Ordnungsfunktion zur Unterscheidung von R1 und D10 (R1 als Fachbegriff).
3. Bei Unterscheidung der beiden vorgenannten Betrachtungsweisen 1. und 2. ist die Bezugnahme in der VDI-Richtlinie 3460 auf R1 damit nicht erforderlich.

## Technical Viewpoint

Before the energy in a waste-to-energy plant can be assessed, it is imperative to establish a balancing system with a balance boundary (balance circle) for the plant (Figure 1).

Mass and energy balances are thereafter carried out on the basis of this balancing system; all flows are indicated, numbered and provided with figures and units [e.g. 2 and 4].

The sum of all incoming flows is checked in order to ensure that it is identical to the sum of all out-going flows. Examples of this can be found in [e.g. 2, 4, 5, 6, 7]. Not only can balances of this kind then be used to assess whether, technically, a net gain or net input has occurred (by means of efficiencies), they also serve as a basis for estimating the potential for improvement or optimisation in waste-to-energy plants [e.g. 8, 9, 10].

Figure 2 illustrates a balance diagram<sup>1</sup> for the energy balance.

For the sake of clarity, the symbols used in [3] are also used here to indicate the incoming and out-going energy flows.

The following flows enter the plant:

- energy flow<sup>2</sup>  $E_w$  in the waste

$$E_w = \dot{m}_{AF} \cdot h_{h,AF} \quad (1)$$

where  $\dot{m}_{AF}$  is the waste mass flow and  $h_{h,AF}$  is the lower heating value of the waste,

- energy flow  $E_f$  in the fuels that “contribute to the generation of steam” (according to [3]),
- other incoming (“imported”) energy flows  $E_i$ , such as those in auxiliary materials, as condensate returns, as electrical energy, etc. (according to [3]).

The following flows leave the plant:

- the usable (“generated”) energy flow  $E_p$ ,
- the unusable energy flow, i.e. plant losses  $E_{ver}$ , e.g. flue gas losses, losses in the solid residues, radiation losses, etc.

To assess energy conversion the so-called energy efficiency is used, which always calculates the ratio of the generated useful energy (gain) to the total energy input required to achieve this gain. Input and output variables must basically be used at one and the same (respectively selected) balance boundary. In the case of balancing circle 1, which encompasses the plant (index “A”) as per Figure 2, the following results:

$$\eta_A = \frac{\text{useful energy}}{\text{total energy input}} = \frac{E_p}{E_w + E_f + E_i}_{\text{balance circle 1}} \quad (2)$$

<sup>1</sup> Reference is made at this point to the previously specified references [2 and 4 to 10] on detailed performance of balances.

<sup>2</sup> “Energy flows” are referred to in abbreviated form as “energies” below.

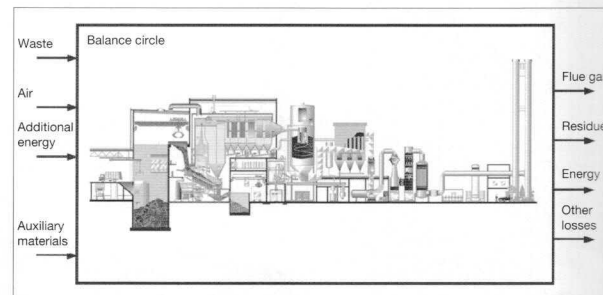

Figure 1. Balancing system of a plant.

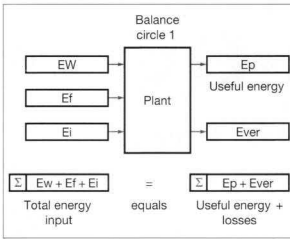

Figure 2. Basic illustration of a balance diagram for the energy balance (description in text).

If there were no waste, the additionally required energies  $E_p$  and  $E_i$  (over and above the energy in waste) would not be needed, i.e. energy resources could be saved equal to the amounts  $E_p$  and  $E_i$ . If the energy efficiency of the plant is to be accessed in terms of the waste used only, the energy input ( $E_f$  and  $E_i$  in Figure 2) over and above that from the waste must be subtracted from the useful energy<sup>3</sup>  $E_p$  in balance circle 1. The net gain  $E_p - (E_f + E_i)$ <sup>4</sup> then remains as the gain. A new balancing system with a (theoretical) returned flow  $E_f + E_i$  appropriately clarifies this subtraction, which is illustrated in Figure 3. There, on the basis of Figure 2, balance circle 2 results by adding the recirculated flow  $E_f + E_i$ . As can be seen, only the energy bound to the waste  $E_w$  is supplied to this balance. Therefore, the net gain (net target energy) can only be attributed to the waste.

Assessment of the plant's energy efficiency based on waste as the sole input (balance circle 2) and using the ratio of net useful

<sup>3</sup> Following [11] the term "target energy" is used in [2] for this purpose. The "net target energy" remains after theoretical return of the energy input over and above that from the waste.

<sup>4</sup> The individual energies  $E_p$ ,  $E_w$ ,  $E_f$  and  $E_i$  are different types of energy, e.g. chemically-bound energy, thermal, electrical energy, etc. and therefore also have different ratings. When determining net useful energy (gain), the input  $E_f$  and  $E_i$  must be subtracted from the generated gain  $E_p$ . In the case of electrical energy, this is not an issue, i.e. the required additional electrical energy can simply be subtracted from the generated electrical energy. However, if the plant produces only thermal energy or if the input in terms of additional fuels (chemically-bound energy) is to be subtracted, more complex substitution considerations are essential. The rating of a particular energy type can be expressed for example by the energy exchange ratio (ratio of the substitution energy, e.g. steam, to the energy to be substituted, e.g. natural gas). Reference is made to [12 to 16] for determining energy exchange ratios and their treatment in the context of balances. For the sake of clarity, the value 1 will be used for energy exchange ratios here.

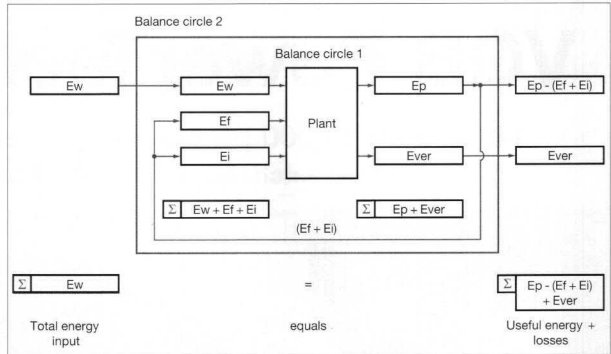

Figure 3. Basic illustration of a balance diagram for the energy balance with recirculation (description in text).

energy (gain) to the total energy input required to achieve this net gain (waste only) results in the efficiency as shown below, and shall now be known as a net plant efficiency,

$$\left( \eta_{A,net} = \frac{\text{useful energy}}{\text{total energy input}} = \frac{E_p - (E_f + E_i)}{E_w} \right)_{\text{Balance circle 2}} \quad (3)$$

The efficiency  $\eta_{A,net}$  can be used to directly assess whether energy recovery is taking place or not.  $\eta_{A,net} > 0$  indicates technical recovery.

In waste-to-energy plants, the energy flows  $E_f$  and  $E_i$  can often remain outside the equation for the first approximation; the following then applies:

$$\eta_A = \frac{E_p}{E_w} \quad (4)$$

According to the VDI guideline 4661 [11],  $E_p$  signifies the sum of electrical ( $P_{el}$ ) and thermal ( $\dot{Q}_{Nutz}$ ) useful energy (gains):

$$E_p = P_{el} + \dot{Q}_{Nutz} \quad (\text{according to [11]}) \quad (5)$$

In connection with the occurrence of different energy types (as in this case thermal and electrical energy), the issue frequently arises of their assessment in comparison with the type of incoming energy supplied, in this case in comparison with the incoming fuel energy flow  $\dot{m}_B \cdot h_{u,B}$ . When different energy types are being assessed, values known as equivalent values are introduced. However, when doing so, attention must be paid to the thermodynamic background, in particular to the generally applicable conservation equations.

To illustrate the use of equivalent values, simple ideal thermodynamic cycles are assumed (Figure 4). The left side of Figure 4 illustrates an ideal gas turbine process, the right side an ideal steam power process.

In this case, absolute flows, i.e. heat flows and the electrical output, are used for the purpose of exemplary observation.

If it is assumed that the gain lies in the production of electrical energy, the electrical efficiency (according to the ratio of areas in Figure 4) for this power plant process is, as illustrated in Figure 4 (simplified T,S diagram):

$$\eta_{\kappa} = \frac{P_{el}}{\dot{Q}_{zu}} \quad (6)$$

In practise, the electricity yield  $\beta$  [11] expressing the ratio of electrical output to the used fuel energy flow (waste energy flow  $E_w$  as per equation (1)) is an important characteristic:

$$\beta = \frac{P_{el}}{\dot{m}_B \cdot h_u} \quad (7)$$

In response to the question which produced electrical output is equivalent to the supplied energy ( $\dot{m}_B \cdot h_u$ ),

$$P_{el} \cdot \dot{a}_{el} = \dot{m}_B \cdot h_u \quad (8)$$

the equivalent value of the electrical energy results as follows:

$$\dot{a}_{el} = \frac{\dot{m}_B \cdot h_u}{P_{el}} = \frac{1}{\beta} \quad (9)$$

or also the relationship:

$$\beta \cdot \dot{a}_{el} = 1^5 \quad (10)$$

The thermal energy flow  $\dot{Q}_{zu}$  required for the cycle is provided by the conversion of fuel

<sup>5</sup> It is important to emphasize that the total supplied fuel energy flow is included when electrical energy is multiplied by its equivalent value ( $\dot{a}_{el} = 1$  as per equation (10), see also equation (8)).

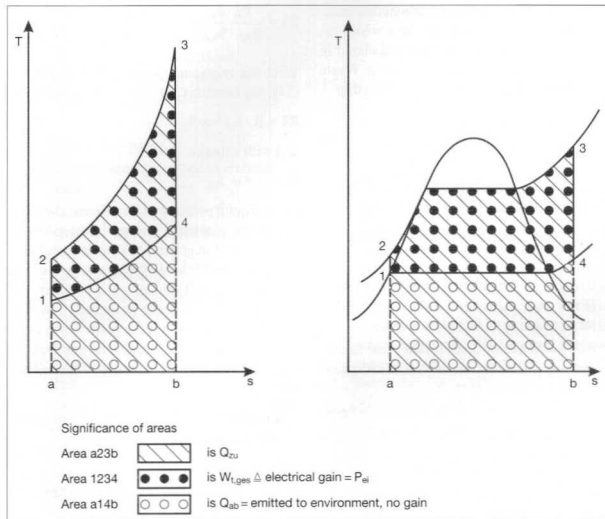

Figure 4. Ideal thermodynamic cycles in the T, S diagram, electrical energy as gain, description in text.

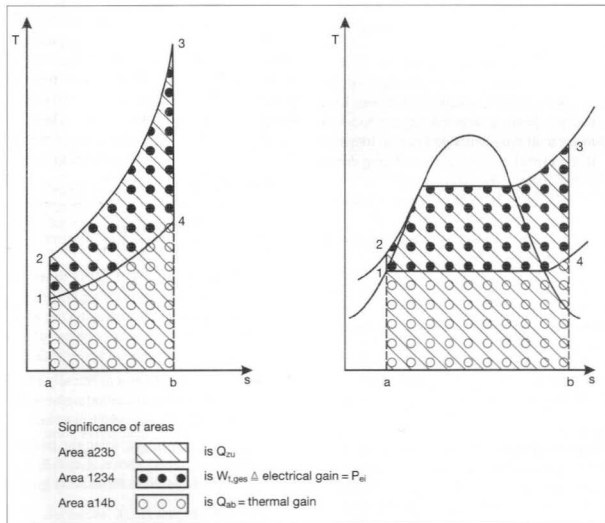

Figure 5. Ideal thermodynamic cycles in the T, S diagram, electrical energy and thermal energy as gain, description in text.

energy ( $\dot{m}_B \cdot h_u$ ). The quality of the conversion can also be expressed in terms of a corresponding thermal efficiency (combustion system/boiler efficiency  $\eta_F$ ):

$$\eta_F = \frac{\dot{Q}_{zu}}{\dot{m}_B \cdot h_u} \quad (11)$$

In line with the afore-mentioned equivalent value  $\dot{a}_{el}$  for electrical energy, there is likewise an equivalent value  $\dot{a}_{th}$  corresponding to

$$\dot{Q}_{zu} \cdot \dot{a}_{th} = \dot{m}_B \cdot h_u \quad (12)$$

for thermal energy  $\dot{Q}_{zu}$

$$\dot{a}_{th} = \frac{\dot{m}_B \cdot h_u}{\dot{Q}_{zu}} = \frac{1}{\eta_F} \quad (13)$$

If thermal energy is produced as a gain in addition to electrical energy (combined heat and power generation), Figure 5 applies.

Area a14b  $\triangleq \dot{Q}_{ab}$  in Figure 4 is no longer a loss in Figure 5. Instead, it is a thermal useful energy (gain)  $\dot{Q}_{Nutz}$  in Figure 5. For combined heat and power generation, the assessment will include heat yield  $\alpha$  [11] in addition to electricity yield  $\beta$  [equation (7)]:

$$\alpha = \frac{\dot{Q}_{Nutz}}{\dot{m}_B \cdot h_u} \quad (14)$$

In line with the electrical efficiency (equation (6)) an efficiency for heat utilisation can be established

$$\eta_w = \frac{\dot{Q}_{Nutz}}{\dot{Q}_{zu}} \quad (15)$$

The sum of the electrical and thermal useful energy (gain) according to [11] is referred to as the fuel yield (fuel utilisation factor)  $\omega$ . It indicates the yield obtained from the fuel energy flow:

$$\omega = \frac{P_{el} + \dot{Q}_{Nutz}}{\dot{m}_B \cdot h_u} = \beta + \alpha \quad (16)$$

The following therefore applies to a plant that produces useful electrical and thermal energy (combined heat and power generation)

$$\eta_{KWK} = \frac{\text{useful energy}}{\text{total energy input}} = \frac{P_{el} + \dot{Q}_{Nutz}}{\dot{Q}_{zu}} = \frac{P_{el}}{\dot{Q}_{zu}} + \frac{\dot{Q}_{Nutz}}{\dot{Q}_{zu}} = \eta_K + \eta_w \quad (17)$$

or in equations (17), (13), (7), (14) and (16),  $\eta_{KWK}$  can also be written as:

$$\eta_{KWK} = \frac{P_{el} + \dot{Q}_{Nutz}}{\dot{Q}_{zu}} = \frac{P_{el}}{\dot{m}_B \cdot h_u} \cdot \dot{a}_{th} + \frac{\dot{Q}_{Nutz}}{\dot{m}_B \cdot h_u} \cdot \dot{a}_{th} = (\beta + \alpha) \cdot \dot{a}_{th} = \omega \cdot \dot{a}_{th} \quad (18)$$

This establishes the connection between the fuel yield  $\omega$  and the efficiency of the cycle with combined heat and power generation  $\eta_{KWK}$ :

$$\omega = \frac{\eta_{KWK}}{\dot{a}_{th}} \quad (19)$$

Taking equation (4)

$$\eta_A = \frac{E_p}{E_w} \quad (4)$$

and

- Ep which is the sum of electrical energy  $P_{el}$  and thermal energy  $\dot{Q}_{Nutz}$   
 $Ep = P_{el} + \dot{Q}_{Nutz}$  (5)

- and Ew, the energy contained in the waste  
 $Ew = \dot{m}_{AF} \cdot h_{u,AF}$  (1)

- combined with the electricity and heat yields  $\beta$  and  $\alpha$  [equations (7) and (14)],

equation (4) can be reformulated:

$$\eta_A = \frac{P_{el} + \dot{Q}_{Nutz}}{\dot{m}_B \cdot h_u} = \beta + \alpha = \omega \quad (20).$$

The main technical procedure for assessing the "fuel utilisation" ( $\omega$  = fuel yield) is thus indicated by [11]. In view of this background, [2] is tailor-made especially for waste-to-energy plants. Further examples can be found in [5, 6].

At this point it is worth mentioning that the aforementioned methodical procedure for balancing and assessing in technological fields can generally be applied to other areas such as:

- The integration of the usage behaviour of a waste-to-energy plant, i.e. if an energy-efficient waste-to-energy plant is not able to transfer the steam it produces to the district heating network in summer and is obliged to release this energy "via the roof" because the consumer does not take it and waste must be combusted (e.g. [2]);
- Determination of primary and net primary efficiency<sup>6</sup> (e.g. [2]);
- General illustration of the process chains
  - Waste-to-energy plants with upstream mechanical-biological waste treatment etc.
  - Biomass power generation, biomass for producing engine fuel;
- Illustration of coupling processes, i.e. the illustration of whether, within existing boundary conditions, it is worthwhile to use a substitute fuel for a clinker firing process in the cement industry or also in an industrial power plant etc. (see e.g. [16]).

**Political/Legal Viewpoint**

In the draft of the Waste Framework Directive [3], the R1 factor (to distinguish between R1<sup>7</sup> and D10<sup>8</sup> (R1 as a technical term)) is

<sup>6</sup> The primary efficiency takes the additionally required primary energy (e.g. for the provision of additional fuels, operating media and auxiliary materials) into account as an input in the assessment. When the net primary efficiency is being determined, this input in the form of primary energy is theoretically replaced by the useful energy "produced". Only the supplied waste energy remains as an input and only the net energy resulting exclusively from the energy content of the waste remains as useful energy (gain), (see [2] for more information).

used to answer the question of whether energy recovery is taking place in a waste-to-energy plant. This R1 factor is calculated in compliance with the currently valid Waste Framework Directive from the relationship:

$$R1 = \frac{Ep - (Ef + Ei)}{0.97 \cdot (Ew + Ef)} \quad (21).$$

If for existing plants<sup>9</sup> R1 > 0.6, the law deems the status to be that of energy recovery.

The abbreviations in this formula (21) are explained below:

- Ew: Ew is the energy flow in the waste ( $Ew = \dot{m}_{AF} \cdot h_{u,AF}$ ) and it therefore has the same meaning as in equation (1).
- 0.97: with factor 0.97, losses "due to bottom ash and boiler ash as well as radiation" are taken into account,
- Ef: Ef is the energy flow in the fuels "contributing to the generation of steam",
- Ei: Ei are other incoming ("imported") energy flows that occur for example in process materials, as condensate returns, as electrical energy, etc.
- Ep: Ep is the usable ("produced") energy flow which consists of electrical energy and thermal energy  $\dot{Q}_{th}$  ( $= \dot{Q}_{Nutz}$ ). However, it must be emphasized that the in-plant requirements have been included, i.e. Ep is, as it were, the "gross" energy "produced", thereby referring to an inner balancing system from which in-plant requirements have not yet been subtracted. It is necessary to subtract the plant's power requirements if the useful energy (gain) is being determined for an "external consumer".

Furthermore, the electrical and thermal energy ("gross energy produced") thus presented is still assessed with the equivalence factors  $\dot{a}_{el}$  and  $\dot{a}_{th}$ , i.e.

$$Ep = P_{el} \cdot \dot{a}_{el} + \dot{Q}_{th} \cdot \dot{a}_{th} \quad (22).$$

(according to [3])

The R1 factor is correspondingly calculated with the formula:

$$R1 = \frac{P_{el} \cdot \dot{a}_{el} + \dot{Q}_{th} \cdot \dot{a}_{th} - (Ef + Ei)}{0.97 \cdot (\dot{m}_{AF} \cdot h_{u,AF} + Ef)} \quad (23).$$

Assuming that, as it is frequently the case, Ef and Ei need not be taken into account for a basic, clear representation, there is a further simplification, so that instead of factor 0.97, factor 1 can be used to simplify formula (23) which results in the following R1 factor:

<sup>7</sup> R1 factor in [3] represents the energy recovery process (main use as fuel or other means of generating energy).

<sup>8</sup> D10 in [3] represents thermal elimination (combustion on land).

<sup>9</sup> Condition for energy use [3] for plants approved before 01.01.2009 R1 > 0.6 and R1 > 0.65 for approved after 31.12.2008.

$$R1 = \frac{P_{el} \cdot \dot{a}_{el}}{\dot{m}_{AF} \cdot h_{u,AF}} + \frac{\dot{Q}_{th} \cdot \dot{a}_{th}}{\dot{m}_{AF} \cdot h_{u,AF}} \quad (24).$$

With the relationships presented in (7) and (14), the formula (24) consequently becomes

$$R1 = \beta \cdot \dot{a}_{el} + \alpha \cdot \dot{a}_{th} \quad (25)$$

and with equation (10)

$$R1 = 1 + \alpha \cdot \dot{a}_{th} \quad (26).$$

Since from a political point of view, the equivalent for electrical energy is the point of orientation, that is number 1 in (26), and thermal gain is additional taken into account, it follows that the R1 factor can be greater than 1. When a plant is being evaluated, however, average values and not the plant's own equivalent values are applied for the practical assessment calculation regulation. These values are:

for generating electrical energy in power plants  $\dot{a}_{el} = 2.6$

and

for the provision of thermal energy in heating stations  $\dot{a}_{th} = 1.1$ .

Due to specified physical boundary conditions in waste-to-energy plants, their electrical efficiency is relatively low compared with other power plants. Therefore, in general, the above mentioned average equivalent values relating to the formula (23) for waste-to-energy plants provide R1 values that are less than 1 (R1 < 1) (down to R1 < 0.5), even though, as explained above, values where R1 > 1 do occur. There are examples of this in [5, 6]. The R1 formula only applies to waste-to-energy plants.

**Resumé**

1. The VDI guideline 3460 [2] is based on known and proven engineering knowledge and forms the basis for assessing the energy efficiency of waste-to-energy plants with particular reference to optimisation.
2. The R1 formula [3] has a politically regulatory function for differentiating between R1 and D10 (R1 as the technical term).
3. When differentiating between the two approaches mentioned above, 1 and 2, it is unnecessary to refer to R1 in VDI guideline 3460.

**Symbols**

**Latin Letters**

- $\dot{a}_{el}$  equivalent value for electrical energy
- $\dot{a}_{th}$  equivalent value for thermal energy
- Ef fuel energy
- Ei other incoming energy
- Ep usable energy

|                      |   |
|----------------------|---|
| E <sub>w</sub>       | waste energy  |
| E <sub>ver</sub>     | energy losses   |
| h <sub>u,AF</sub>    | waste – lower heating value                               |
| h <sub>u</sub>       | fuel – lower heating value                                |
| m <sub>AF</sub>      | waste mass flow   |
| m <sub>B</sub>       | fuel mass flow  |
| P <sub>el</sub>      | electrical power  |
| Q <sub>ab</sub>      | thermal energy emitted to environment                     |
| Q <sub>th</sub>      | thermal useful energy (= Q <sub>Nutz</sub> ), gain        |
| Q <sub>zu</sub>      | thermal input (thermodynamic cycle process)               |
| Q <sub>Nutz</sub>    | thermal useful energy (= Q <sub>th</sub> ), gain          |
| W <sub>teges</sub>   | total technical power (thermodynamic cycle process), gain |
| <b>Greek Letters</b> |   |
| α                    | heat yield  |
| β                    | electricity yield   |
| η                    | efficiency  |
| η <sub>A</sub>       | plant efficiency  |
| η <sub>A,net</sub>   | net plant efficiency                                      |
| η <sub>F</sub>       | combustion system/boiler efficiency                       |
| η <sub>K</sub>       | electrical efficiency                                     |
| η <sub>KWK</sub>     | combined heat and power efficiency                        |
| η <sub>w</sub>       | thermal efficiency  |
| ω                    | fuel yield  |

References

[ 1 ] Verein Deutscher Ingenieure (Hrsg.): Richtlinie VDI 1000 – Richtlinienarbeit – Grundsätze und Anleitungen. März 1999.

[ 2 ] Verein Deutscher Ingenieure VDI (Hrsg.): Richtlinie VDI 3460 Blatt 2 Emissionsminderung – Energieumwandlung bei der thermischen Abfallbehandlung. August 2007.

[ 3 ] Kommission der europäischen Gemeinschaften (Hrsg.): Vorschlag für eine Richtlinie des europäischen Parlaments und des Rates über Abfälle (von der Kommission vorgelegt). Brüssel, den 21.12.2005 KOM (2005) 667 endgültig – 2005/0281 (COD), Anhang II, S. 34.

[ 4 ] Scholz, R., Beckmann, M., Schulenburg, F.: Abfallbehandlung in thermischen Verfahren. Verbrennung, Vergasung, Pyrolyse, Verfahrens- und Anlagenkonzepte. Teubner-Reihe UMWELT, B. G. Teubner GmbH, Stuttgart/Leipzig/Wiesbaden 2001.

[ 5 ] Beckmann, M., Scholz, R.: Ermittlung der Energieeffizienz in Anlagen zur thermischen Abfallbehandlung. Zur Problematik von Äquivalenzwerten und der Berechnung des Heizwertes. In: Thomé-Kozmiensky, K. J.; Beckmann, M. (Hrsg.): Energie aus Abfall – Band 2. TK Verlag Karl Thomé-Kozmiensky, 2007.

[ 6 ] Beckmann, M., Scholz, R., Seifert, H., Notrodt, A.: Bewertung der Energieeffizienz in Anlagen zur thermischen Abfallbehandlung. Stellungnahme des Ausschusses VDI 3460.

In: Thomé-Kozmiensky, K. J.; Beckmann, M. (Hrsg.): Energie aus Abfall – Band 2. TK Verlag Karl Thomé-Kozmiensky, 2007.

[ 7 ] Scholz, R., Beckmann, M., Harnaut, T., Horeni, M.: Zur systematischen Bewertung der Energieumwandlungen bei der thermischen Abfallbehandlung. Was ist Energieeffizienz? In: Thomé-Kozmiensky, K. J. (Hrsg.): Optimierung der Abfallverbrennung 1. TK Verlag Karl Thomé-Kozmiensky 2004.

[ 8 ] Beckmann, M., Horeni, H.: Möglichkeiten zur Optimierung von Müllverbrennungsanlagen durch Einsatz eines Online-Bilanzierungsprogramms. erschienen in: VDI Wissensforum IWB GmbH (Hrsg.): 22. Deutscher Flammtag – Verbrennung und Feuerungen. Tagung Braunschweig, 21. und 22. September 2005. VDI-Berichte Nr. 1888, VDI Verlag GmbH Düsseldorf 2005.

[ 9 ] Beckmann, M., Horeni, M., Metschke, J., Krüger, J., Papa, G., Englmaier, L., Busch, M.: Optimierung von Müllheizkraftwerken durch Einsatz eines Online-Bilanzierungsprogramms. Erschienen in: Thomé-Kozmiensky, K. J. (Hrsg.): Optimierung der Abfallverbrennung 2. TK Verlag Thomé-Kozmiensky, 2005, S. 219 – 239.

[ 10 ] Horeni, M., Beckmann, M., Fleischmann, H., Barth, E.: Ermittlung von Betriebsparametern in Abfallverbrennungsanlagen als Voraussetzung für die weitere Optimierung. In: Thomé-Kozmiensky, K. J.; Beckmann, M. (Hrsg.): Energie aus Abfall – Band 2. TK Verlag Karl Thomé-Kozmiensky, 2007.

[ 11 ] VDI 4661: Energiekenngrößen – Definitionen – Begriffe – Methodik. Beuth-Verlag GmbH Berlin, September 2003.

[ 12 ] Lüth, F.: Die Wertigkeit von Gasen gegenüber anderen Brennstoffen und Energien in der Industrie. Stahl und Eisen 78 (1958), Nr. 15.

[ 13 ] Kahnwald, H.: Wärmetechnische Bewertung von gasförmigen und flüssigen Austauschbrennstoffen. Archiv für das Eisenhüttenwesen. 35. Jahrg. (1964), Heft 10.

[ 14 ] Görgen, R., Kahnwald, H.: Vergleichende Bewertung von Gasen. Gaswärme International, Bd. 17 (1968), Nr. 2, S. 50-53.

[ 15 ] Michalowski, M., Wessely, R.: Bewertung der komplexen Austauschbarkeit von Brenngasen in Hüttenwerken. Arch. Eisenhüttenwesens 54, Nr. 6, 1983.

[ 16 ] Beckmann, M., Scholz, R.: Energetische Bewertung der Substitution von Brennstoffen durch Ersatzbrennstoffe bei Hochtemperaturprozessen zur Stoffbehandlung. Teil 1: ZKG International 52 (1999) Heft 6, S. 287-303. Teil 2: ZKG International 52 (1999) Heft 8, S. 411-419. □

kraftvoll

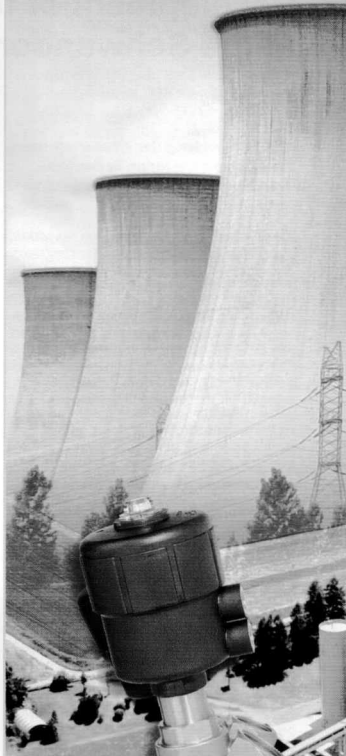

Die Bedeutung der Kraftwerke wird in den nächsten Jahrzehnten zunehmen.

Deshalb entwickelt Buschjost in den Bereichen der konventionellen und nuklearen Kraftwerke vielfältige Anwendungen, die über Filterabreinigung, Wasserzu- und Abfuhr, Rauchgaswäsche, Generatorkühlung bis hin zu Dampfanwendungen reichen.



IMI NORGREN BUSCHJOST GMBH + CO. KG  
D-32545 Bad Oeynhausen • Tel. 0 57 31 / 7 91-0  
mail@buschjost.de