

Englische Fassung:

HITEMAGEN4

“High Temperature Materials for Liquid Salt Cooled Generation IV Reactor Concepts”

Project manager: Prof. Dr.-Ing. Antonio Hurtado

Contributors: Dipl.-Ing. Torben Maier-Knop

Duration: 09/2024 – 08/2027

Funding: Projektträger Karlsruhe (PTKA)

Funding Code: 02NUK094B

Cooperation: KSB SE & Co. KGaA

Brief description of the project:

Thermal power plants play a central role in global energy supply concepts. To increase the efficiency of these power plants, the generated waste heat is utilized at the highest possible temperature difference. Molten salts are particularly suitable as heat transfer media and as efficient heat storage media at very high operating temperatures (e.g.: Carnot batteries or PCM, phase change material).

The nitrate salt melts currently used are stable up to around 500 °C before undergoing chemical decomposition. For higher temperatures, alternative salts such as chloride salts are of interest due to their high thermal stability, allowing them to withstand temperatures of up to 800°C. However, these salts contribute to corrosion of the materials used in power plant components, particularly in the high-temperature range, posing a challenge for the long-term operational safety of the facilities. It is therefore necessary to identify construction materials that exhibit high corrosion resistance at the aforementioned temperatures. Molten salt reactors as representatives of the generation IV technology use molten salts (chloride or fluoride molten salts) both as a coolant and as a fuel carrier.

The HITMAGEN4 project aims to identify suitable construction materials for use in hydraulic systems, particularly with regard to molten salt reactors. The project partner KSB SE & Co. KGaA coordinates the project and, as a globally operating German company with a long-standing tradition in the manufacture of pumps and valves, contributes extensive expertise in the field of hydraulic system technology to the project. At the beginning of the project, the thermochemical and thermomechanical resistance of materials, seals and joints will be examined under realistic reactor conditions in molten chloride salt. Using the COSMOS (**CO**rrosion and Heat **S**torage test facility for **MO**lten **S**alts) test facility developed at TU Dresden, test samples will be examined in both static and flowing molten chloride salt at temperatures of up to 800 °C. In the later stages of the

project, the insights gained will be applied to the manufacturing of components and their testing within COSMOS. The qualitative and quantitative analysis of the corrosion attack should contribute to a better understanding of corrosion processes in molten chloride salt and expand the material selection for the primary cooling circuit of molten salt reactors.

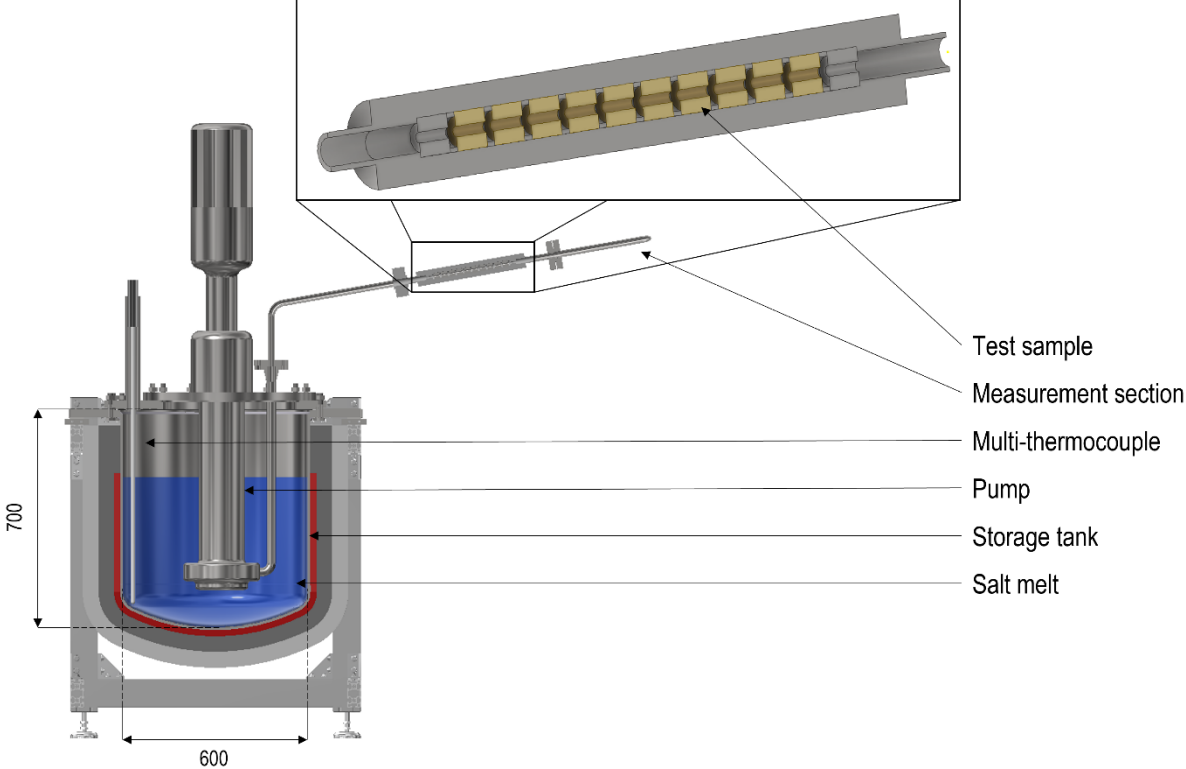

Figure: Sectional view of the COSMOS test facility. The detailed view shows the measurement section for corrosion investigation in flowing molten salt.